



EVID 3.2 SOS Monitor and MA-3 Mic Stand Adapter

The EVID 3.2 SOS is a near-field monitor with volume control and 1/4" input jack that can be easily mounted on a microphone stand for convenient placement anywhere. An adjustable swivel lets you mount it at exactly the right angle for any application.

MA-3 Mic Stand Adapter kit lets you mount any standard EVID 3.2 on a microphone stand for easy placement anywhere you need it.



MA-3 Kit Includes:		
Item	Qty	Description
1	1	Mic Stand Adapter
2	1	Boom Adapter
3	2	Flat Washer (.88" O.D., .25" I.D.)

EVID 3.2 SOS Monitor Includes:		
Item	Qty	Description
1	1	Mic Stand Adapter
2	1	Boom Adapter
3	2	Flat Washer (.88" O.D., .25" I.D.)
4	1	EVID 3.2 Monitor, with 1/4" Jack
5	1	Shock-Proof Microphone Mount

Mic Stand Mounting (MA-3 and SOS)

Step 1:

Attach the Mic Stand Adapter (Item 1) to your microphone stand (not included).

Step 2:

Attach the EVID 3.2 (or the 3.2 SOS) to the Mic Stand Adapter using one flat washer (Item 3) in-between the Adapter and the EVID.

Step 3:

Use the adjustment knob to adjust the angle of the EVID.

If not attaching a boom to the EVID, attach Logo Cap as shown.

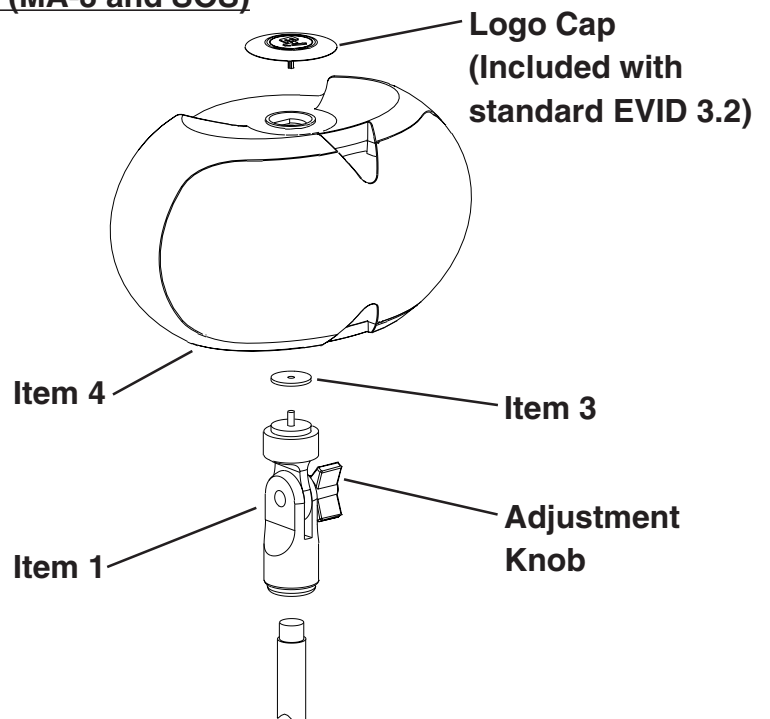

Mounting a Microphone and Boom to your EVID (MA-3 and SOS)

Step 1:

Attach the Boom Adapter (Item 2) to the top of the EVID with a flat washer (Item 3) in between the Adapter and the EVID.

Step 2:

Mount the Boom (Not Included) to the Boom Adapter (Item 2).

Step 3:

Replace any microphone mount with the Shock-Proof Mic Mount (Item 5, EVID 3.2 SOS only).

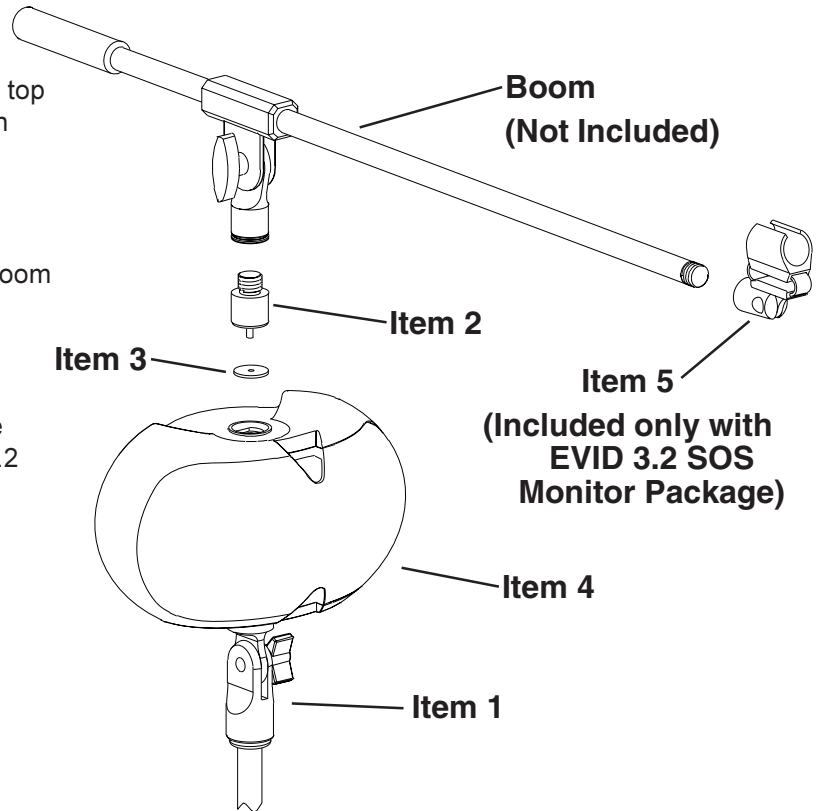

EVID 3.2 SOS Rear Panel Detail

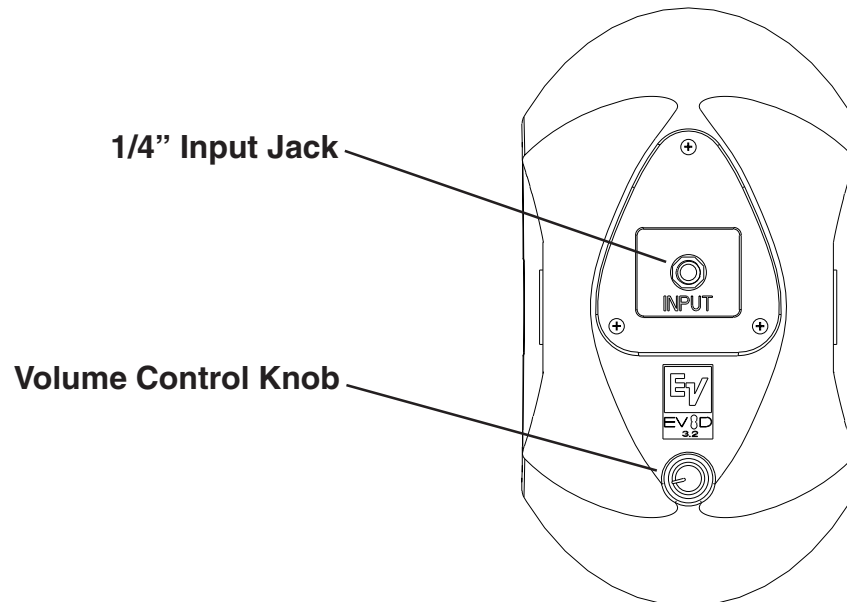

EV ElectroVoice®

12000 Portland Avenue South, Burnsville, MN 55337
Phone: 952/884-4051, Fax: 952/884-0043

www.electrovoice.com

© Telex Communications, Inc. 1/2002

U.S.A. and Canada only. For customer orders,
contact the Customer Service department at
800/392-3497 Fax: 800/955-6831
Europe, Africa and Middle East only. For customer orders,
contact the Customer Service department at
49 9421-706 0 Fax: 49 9421-706 265
For warranty information, contact the Service Repair department at:
616/695-6831 or 800/685-2606
For technical assistance, contact Technical Support at:
866/78AUDIO

Specifications subject to change without notice.

© Telex Communications, Inc. 1/2002