

R300 | UHF WIRELESS MICROPHONE

USER GUIDE

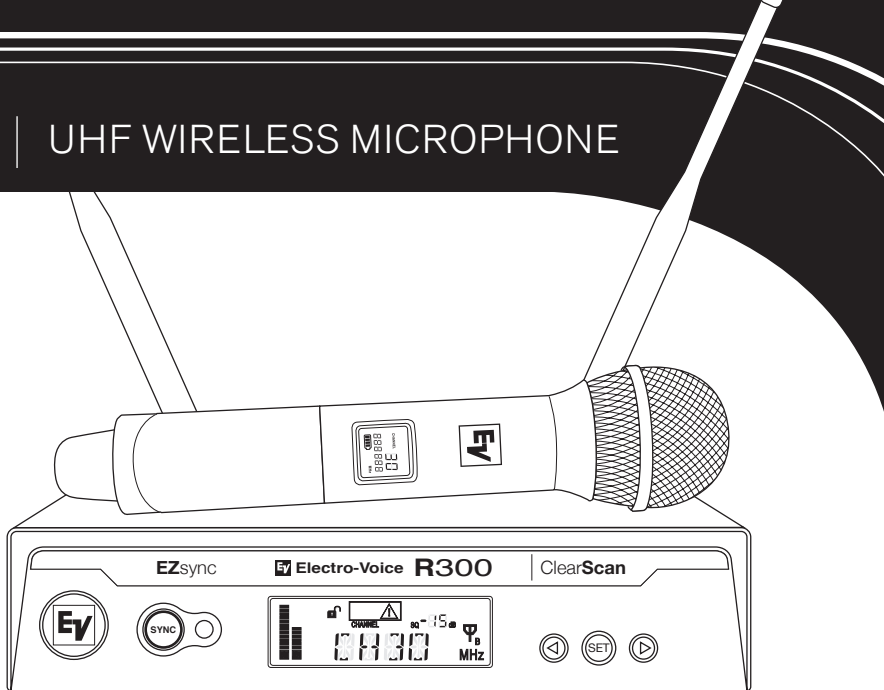

CE11770



TABLE OF CONTENTS

1. Quick System Setup	
▪ Receiver.....	4
▪ Transmitter.....	5
▪ Systems Operation.....	6
2. Detailed Component Descriptions	
▪ Receiver.....	7-14
▪ Handheld Transmitter.....	15-16
▪ Bodypack Transmitter.....	17-19
3. Guidelines For Best Performance.....	20-21
4. Troubleshooting Guide.....	22-23
5. Specifications.....	24-25
6. Certifications.....	26
7. Service and Warranty.....	27
8. Components and Accessories.....	28
9. Appendix A Compatible Channel Groups.....	29-31

QUICK SET-UP: RECEIVER

1. Do not connect the receiver to any other equipment yet!
2. Connect the two Antennas to the receiver.
3. Install the blades into the power supply, plug it into the back of the receiver, and into an outlet.
4. Press the POWER switch. Display will light up.
5. Press and hold the ► button until CLEARSCAN scrolls across the screen.
6. When CLEARSCAN stops, the receiver will be set to the clearest channel.
7. Turn the receiver off and connect the mixer or other audio system to the receiver XLR Connector or the ¼ inch Line Level Jack.
8. Set the audio mixer or other system input level to minimum.
9. Press the Power switch button in again.

Receiver “Quick Set-up” is complete.

QUICK SET-UP: TRANSMITTER

1. With the Power switch on the transmitter OFF, install two fresh AA batteries into the transmitter.
2. Press the transmitter Power Switch until the display comes on.
3. Hold the transmitter with the EZsync Port facing the receiver, about a foot (30 cm) away.

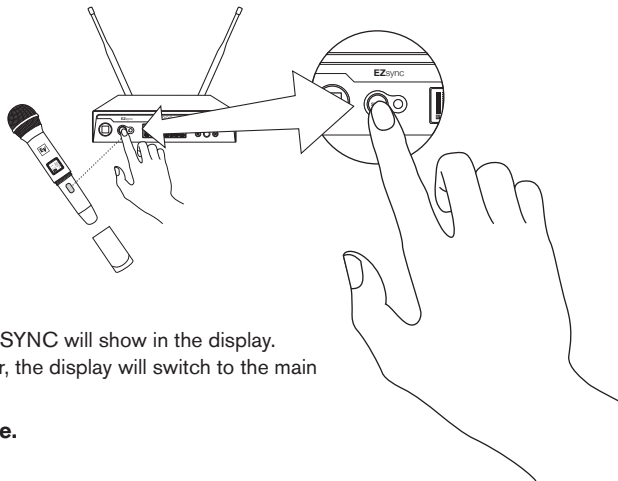

4. Press the SYNC Button on the receiver, SYNC will show in the display.
5. Once the channel is set in the transmitter, the display will switch to the main display and show RF and Audio Levels.

Transmitter “Quick Set-up” is complete.

1. Set the mixer/amp gain.
2. Talk or sing into the microphone or play the guitar at a normal volume. You should hear audio coming out of the system.
3. You may have to adjust the gain (via the control next to the connector on the receiver back panel) to provide the best input volume for your mixer/amp.

“Quick Set-up” is now complete. Please enjoy your R300 system.

2.1 | R300 Receiver

RECEIVER CONTROLS, CONNECTORS

1. Power ON/OFF
2. SYNC Data Transfer Button
3. Infrared EZsync Window
4. Graphical Display
 - a. Channel or Frequency Display
 - b. Diversity Indicator
 - c. RF Strength Meter
 - d. Audio Level Meter
 - e. Lock Indicator
 - f. Squelch Level Indicator

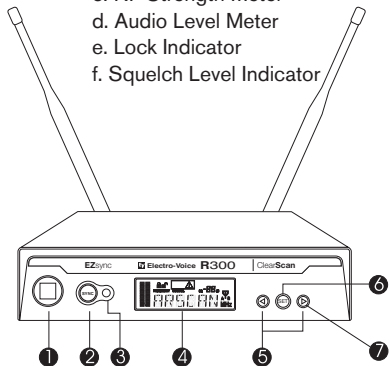

5. Scroll Down and Up (◀ and ▶) Control Buttons
6. SET Control Button
7. ClearScan Control (press and hold ▶ button)
8. TNC Antenna Input Connectors (2)
9. Balanced Output Volume Control
10. XLR Balanced Output Connector
11. ¼ Inch Unbalanced Line Level Audio Output Connector
12. Unbalanced Output Level Switch (-10dB or 0dB)
13. DC Power Connector (12V DC, 500mA)
14. Power Cord Retainer

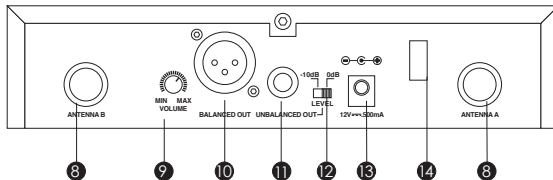

2.1 | Receiver Setup & Operation

1. Place the receiver and antennas where there is a clear line of sight to the area where the transmitter will be used. Rotate the antennas to separate them by 90 degrees.
2. **Install the appropriate power connection blades into the power supply and connect the power supply cord to the receiver.** Plug the power supply into an AC outlet. Push the power button to turn the receiver on and confirm that it is on by checking the main display screen.

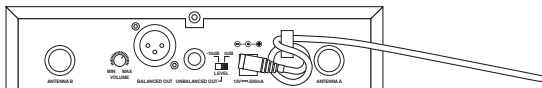

3. Manual Channel Change

- a. The ◀ and ▶ buttons allow you to scroll through the Channels. When the Channel you desire is displayed, stop scrolling.
- b. After 2 seconds the displayed channel number will start to flash.
- c. The number will stop flashing and the new channel is installed.
- d. Turn on the transmitter and hold the EZsync port facing the receiver EZSync port, about a foot (50 cm) away.

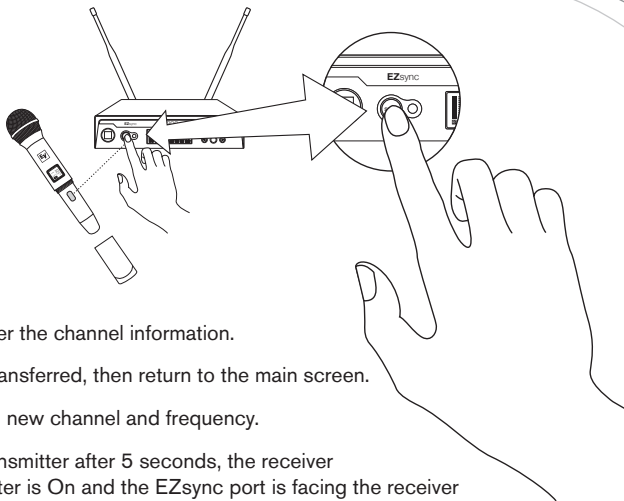

- e. Press the SYNC button on the receiver to transfer the channel information.
- f. The receiver will display SYNC until the data is transferred, then return to the main screen.
- g. The transmitter display screen will now show the new channel and frequency.
- h. If the channel data was not transferred to the transmitter after 5 seconds, the receiver will display ERROR. Be certain that the transmitter is On and the EZsync port is facing the receiver and try again.
- i. If the data still does not transfer, try new batteries, or move the unit to a shaded area away from direct sunlight before trying again.

4. **ClearScan:** This feature automates the process of finding a clear channel.
 - a. To scan for the clearest channel in a group, press and hold ► until CLEARSCAN appears in the display, then release the button.
 - b. When the scan is complete, the display will show the clearest available channel.
 - c. Use the SYNC button to transfer the new channel as in step 3.
5. During set up make sure the mixer or amplifier input used for the R300 is muted or turned down to a minimum level.
6. Plug an audio cable (not supplied) into the 3 pin XLR or ¼ inch output of the R300.

Note: The XLR connector is the preferred connection since the output is balanced and will be more immune to noise for longer runs of cable although either can be used with good results. Set the balanced output level on the back panel to 12 o'clock (midway in the range) to start and adjust later if necessary. If the ¼ inch unbalanced output is used, start with adjustment switch in the -10dB setting.

7. With the transmitter on, speak into the microphone or play the guitar. Turn up the level on the mixer or amplifier until you are able to hear the desired signal. If no audio is present, repeat setup and refer to the troubleshooting section.

Note: It may be necessary to adjust the receiver output until the volume level from the wireless system approximates the level of an equivalent wired microphone/instrument.

8. **DISPLAY** The main display can be adjusted to display the Channel number or the Frequency

Note: At any time the item not selected for the main display can be shown for 5 seconds by pushing the SET button once

- a. Press and hold the SET button until DISPLY shows in the display.
- b. Press SET and FREQUENCY or CHANNEL will flash in the display.
- c. Press ◀ for FREQUENCY or ▶ for CHANNEL and press SET.
- d. Display will return to the main screen and the selected item will be displayed.
- e. At any time the item not selected for the main display can be shown for 5 seconds by pushing the SET button once.

9. **Change Lock-Out** This feature can be useful when the receiver is in a location where unauthorized personnel have access to the receiver. With the LOCK ON, the channel cannot be changed and the word LOCK is displayed when the ◀ or ▶ button is pushed.
- Press and hold the SET button until DISPLY shows in the display.
 - Press ▶ to display LOCK
 - Press SET and ON or OFF will be displayed to show the status of the lock-out.
 - Press ◀ to turn the LOCK ON or ▶ to turn the LOCK OFF and press SET.
 - Display will return to the main screen and padlock symbol in the upper left of the display will show the lock status.

-
10. **Squelch Adjustment** – The squelch setting can be used to maximize range or immunity to noise.
- a. Turn the transmitter off.
 - b. Press and hold the SET button until DISPLY shows in the display.
 - c. Press ► two times to display SQELCH.
 - d. Press SET and the squelch setting in the middle right of the screen (SQ 10dB) will flash.
 - e. Press ◀ to decrease the squelch setting or ► to increase it.
 - f. Press SET to enter the new setting and return to the main screen.
 - g. Turn on the transmitter and walk test the unit. Maximum squelch (50dB) maximizes noise immunity but limits the range. Minimum squelch (5dB) will maximize the range but allow more noise to break through the squelch. **Never leave the squelch set to 0dB except for testing, white noise will be constantly present on the audio outputs.**
 - h. Repeat to fine tune squelch to the desired setting.

2.1.2 | Receiver Main Operating Screen

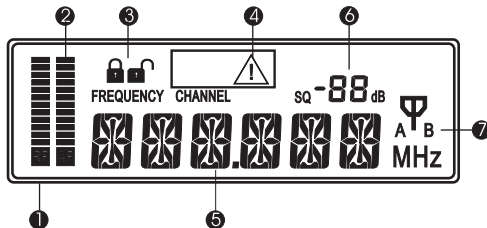
**Display:**

1. RF Signal Meter
2. Audio Meter
3. Lock Indicator
4. No Signal Indicator
5. Channel Number (01 to 32) or Frequency
6. Squelch Setting
7. Antenna Diversity Status A or B antenna

Controls:

1. Press ◀ or ▶ to change channels
2. Press and hold ▶ for 3 seconds starts ClearScan, CLEARSCAN scrolls across the display.
3. Press SET once to display FREQUENCY or CHANNEL, whichever is not showing
4. Press and hold SET for 3 seconds to access settings menu.

2.2 | Handheld Transmitter

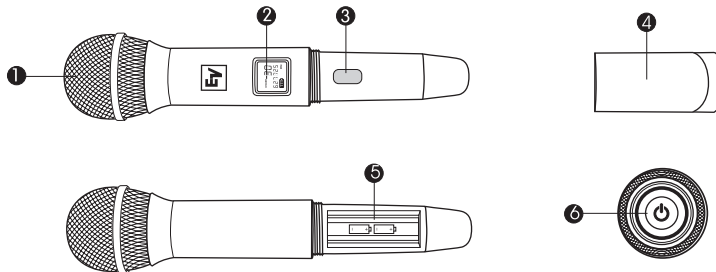

HT-300 CONTROLS, CONNECTORS AND INDICATORS

1. Microphone Element
2. Backlit LCD Display
 - a. Channel
 - b. Frequency
 - c. Battery Level
 - d. Mute Indicator
3. EZSync Infrared Port
4. Battery Cover – Screw type.
5. Battery Compartment – Two AA Batteries
6. On/Off/Mute button

2.2 | Handheld Transmitter Setup & Operation

1. Insert Batteries.

- Remove the battery compartment cover by unscrewing it completely.
- Insert two AA batteries as shown, sliding one up into the housing to make room for the other.

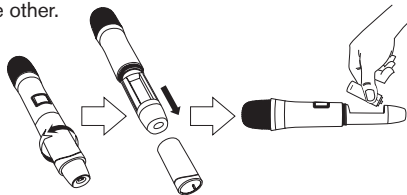

- Turn the unit on by pressing and holding the on/off button for 3 seconds, and the display will light up.
- If a new channel is desired, use EZsync as in Section 2.1 and close battery compartment.
- 4. Verify reception.**
 - With the transmitter and receiver on a matching Channel, the main receiver display should be indicating a RF signal on the bar graph.
 - Speak into the microphone and the Audio Meter bar graph should indicate audio signal presence.
 - If the level meters do not show reception, make sure the channels are matching and refer to the trouble shooting section.

5. **Mute Function** – press and hold on/off button for 2 seconds until MUTE appears in the LCD Display between the Channel and Frequency. The sound is then muted. Repeat to turn mute off.

2.3 | Bodypack Transmitter

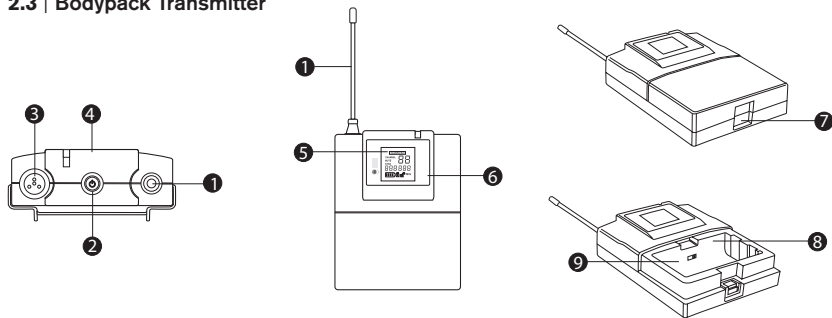

BP-300 CONTROLS, CONNECTORS AND INDICATORS

- | | |
|--------------------------------------|---|
| 1. Antenna – Flexible ¼ wave antenna | 3. TA4 Microphone Connector |
| 2. Power On/Off/Mute Button | 4. On/Mute LED – Green when transmitter is on, Red when muted |

continued on next page

2.3 | Bodypack Transmitter *continued*

5. LCD Display

- a. Channel
- b. Frequency
- c. Battery Level
- d. Mute Indicator

6. EZsync infrared window

7. Battery Compartment Latch – push down latch and slide cover as shown.

8. Two AA Battery Compartment – follow polarity as marked

9. LAV/INS Gain Switch

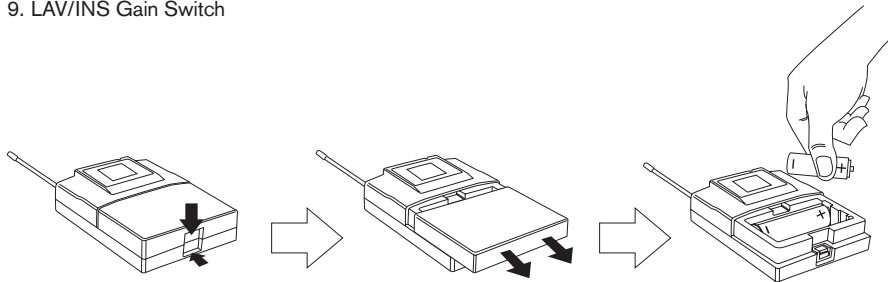

2.3.1 | Bodypack Transmitter Setup & Operation

1. Insert Batteries

- a. Open the battery compartment by pressing in on the latch and sliding the door down.
 - b. Insert two AA batteries with + and – as indicated.
 - c. Close the battery door by pushing up.
2. Turn the unit on by pressing and holding the on/off button for 3 seconds, and the LCD display will light up. If channel has not been set, set channel according to 2.1.

3. Microphone/Guitar Operation.

- a. For Lapel Microphones the gain switch should be in the LAV position.
 - b. For Headworn Microphones and Guitar operation the gain switch should be in the INS position.
 - c. If lapel microphones are too sensitive and the audio meter on the receiver is reaching the peak, put the gain switch in INS to lower the gain.
4. **Mute Function** – press and hold on/off button for 2 seconds until MUTE appears in the LCD Display, between the Channel and Frequency. The LED above the display will turn red and the sound is muted. Repeat to turn mute off.

Compatibility

The transmitter and receiver must be of the same frequency band and set to the same channel in order to work together. The R300 is available in three frequency bands, A, B and E (Europe only). The band information is available in the label on the bottom of the receiver, the label in the battery compartment of the handheld transmitter, and on the back panel label in the bodypack.

Using Multiple Wireless Systems

If three or more R300 systems and/or other UHF/VHF wireless systems are being used in the same location, proper frequency coordination is necessary to avoid interference. Some channels in the R300 are designed to work together, see the channel maps in the back of the guide for more information. Contact your dealer or Electro-Voice for assistance if you are planning more systems or using the R300 with other wireless equipment.

Multiple Systems and R300

The ClearScan function can be used to set up any two R300 systems. Just scan with the first unit, set the transmitter to that clear channel and leave it on. Then scan the second unit for another clear channel. If 3 or more systems are used in the same room, put all of the channels in the same group as indicated by the channel map on page 29-31.

Potential Sources of Interference

There are many potential sources of interference for your wireless system. Any electronic product that contains digital circuitry including digital signal processors (reverb/multi-effects units), electronic keyboards, digital lighting controllers, CD and DVD players, and computers, all emit RF energy that can

adversely affect the performance of your wireless system. It is always best to place the receiver as far away as possible from these devices to minimize potential problems.

Analog and Digital Television stations can also interfere with your wireless system. The R300 is designed to operate over 16MHz of RF bandwidth, which covers 3 US TV stations. If two of the three stations are used in your area, it will severely limit the number of systems that will operate together and you should be using a different band.

Battery Recommendations

Fresh AA alkaline batteries from a quality manufacturer will yield the best performance from your R300 transmitters. If sound quality degrades during use, it may be the result of a weakening battery.

Receiver and Antenna Placement

Do not place the receiver near a large metal object or surface. Locate the receiver as close as possible to the area where the transmitter will be used. Ideally, position the receiver/antennas are within sight of the transmitter. When using multiple systems, do not allow antennas to cross or touch each other.

Transmitter and Antenna Distance

Keep all transmitters at least 3 meters (10ft) away from the receivers and antennas for best operation. If possible, mount the receive antennas 3 meters (10ft) above the stage so transmitters can not come too close.

Problem	Possible Causes	Solutions
No audio and no display on the receiver	Receiver is off	Make sure that the power supply is properly connected and the on/off button is in the on position
No audio and no RF signal indicator on the receiver display	Transmitter is off	Turn on transmitter power switch
	Transmitter is on a different channel or is a different band	Check band information on serial number label and match to receiver, reset channel (see section 2.1)
	No (or dead) battery in transmitter	Insert fresh batteries in transmitter
	Faulty battery contacts	Clean and or bend contacts to improve connection
No Audio with good RF signal indicator	Microphone not connected	Check the TA4F connector on the bodypack or the detachable microphone element connection on the handheld. If possible, try another microphone.
	Transmitter Mute On	Press and hold On/Off button to stop Mute.
No (or low) Audio with good RF signal and Audio indicators on receiver display	Receiver audio output cable is damaged or disconnected	Connect, repair or replace cable
	Gain not sufficient on mixer/preamp/amp input or it is muted	Increase gain on mixer or un-mute the input
	Receiver output too low	Increase the audio output setting.
Distorted audio signal	Receiver output too high	Decrease the receiver output setting
	Loud instrument or audio source	Change the bodypack gain switch to INS
	Battery level low in transmitter	Insert fresh batteries in transmitter
Interference	Another R300 system in the installation is on the same channel or signals are mixing	Make certain all units are on different channels. If more channels are needed call EV at 800-392-3497 for coordination help

Problem	Possible Causes	Solutions
Interference	Another wireless product in the area is on the same frequency or the signals are mixing	Use ClearScan to change the operating frequency. If problems persist, call EV at 800-392-3497 for coordination help
	Receiver is too close to digital signal processor or similar device	Move the receiver to a different location
	Strong electromagnetic field from stage lighting or other source near the transmitter or receiver, which may be producing RF noise at or near the operating frequency	Use ClearScan to change the operating frequency. Repair or remove the source of interference. Move the receiver to a different location
Short range or drop-outs	RF reflective metal obstacles between the transmitter and receiver	Move the obstacles, or reposition the receiver/antennas
	Poorly oriented backpack antenna	Check the antenna connection and reorient the bodypack so the antenna is vertical (up and down) and facing the receiver, if possible
	Squelch set too high	Check squelch setting, higher settings mean shorter range
	Faulty receiving antenna system	Check all antenna connections and reposition to be in line-of-sight with the transmitter
Can't change settings on receiver	Lockout feature is enabled	Disable lockout by pressing SET for 3 seconds, press ► to display LOCK, press SET, press ► to turn lock off, press SET.

SPECIFICATIONS

R300 Receiver	
Receiver Type	Synthesized PLL
Frequency Range (RF)	A Band 618 – 634MHz B Band 678 – 694 MHz E Band 850 – 865 MHz
Number of Channels	32
Modulation	+/- 40 kHz
Diversity	Antenna
RF Sensitivity	< 1.0 μ V for 12 dB SINAD
Image Rejection	> 55dB
Squelch	Tone Code plus Amplitude
FCC Certification	Approved under Part 15
Power Requirements	12 - 16 VDC, 500mA max
Operating Temperature	5° to 45° C (41° to 113° F)
Dimensions	1.72" H x 7.8" W x 8.0" D 43 mm H x 206 mm W x 210 mm D

Audio Parameters	
Frequency Response	80 – 18kHz +/- 2dB
Balanced Output	20 dBV (max @ 40 kHz deviation)
Unbalanced Output	Adjustable 8 mV to 0.755V RMS
Distortion	< 1.0%, 0.4% typical (ref 1kHz, 40kHz deviation)
Signal-to-Noise Ratio	> 100dB A Weighted
Dynamic Range	> 95dB
Transmitters BP-300 and HT-300	
Radiated Output	8 mW typical
Microphone Head ElectroVoice	PL22 Dynamic
Power Requirements	Two AA Batteries
Standard Lavalier Microphone	EV ULM18 Uni-Directional Condenser
TA4F Connector Wiring	Pin 1: Ground; Pin 2 Mic Input; Pin 3: +5V bias; Pin 4: N/C
Power Requirements	Two AA Batteries
Battery Life (Typical)	> 14 hours with AA Alkaline Typical
Bodypack Antenna	Flexible external ¼ wave
Handheld Antenna	Internal Proprietary
Dimensions (Handheld)	26.7 cm (10.57 in.) Long
Dimensions (Bodypack)	3.3 in. H x 2.6 in. W x 0.89 in. D 84 mm H x 66 mm W x 23 mm D

(Depending on frequency selected and country of operation)

R300 receiver, HT-300 and BP-300 transmitters: Certified to ETSI EN 300 422-2 and ETSI EN 301 489-9, Conforms to European Union directives, eligible to bear CE marking as per the R&TTE directive.

R300 receiver: Certified for use in Canada under RSS 210 Issue 5. HT-300 and BP-300 transmitters: Certified for use in Canada under RSS 123 Issue 1.

R300 receiver: Authorized under U.S. Federal communications Commission Part 15.
HT-300 and BP-300 transmitters: Certified under U.S. Federal Communications Commission Part 74.

These devices comply with Part 15 of the FCC Rules. Operation is subject to the condition that the device does not cause harmful interference.

Licensing of this equipment is the user's responsibility and is determined by the user's classification, the user's application, and frequency selected. The user should contact the appropriate telecommunications authority for any desired clarification. Any changes or modifications made to the aforementioned equipment, by the user, could void the user's authority to operate the equipment.

This equipment is intended for use in wireless microphone applications.

Equipment intended for sale in (ISO 3166-1, 2 letter country code): AT, BE, BG, CY, CZ, DK, EE, FI, FR, DE, GR, HU, IS, IE, IT, LV, LT, LU, MT, NL, NO, PL, PT, RO, SK, SI, ES, SE, CH, GB.

This equipment is in compliance with the following directives:
2002/95/EC RoHS Directive and 2002/96/EC WEEE Directive

Please dispose of the base station and transmitters at the end of its operational life, by taking it to your closest collection point or recycling center.



Factory Service (North America)

If factory service is required, ship the unit prepaid in its original carton to:

EV Audio Service

c/o Bosch Security Systems, Inc.

8601 East Cornhusker Highway

Lincoln, NE 68507-9702 U.S.A.

Tel: 402-467-5321 or 800-553-5992

Fax: 402-467-3279

Enclose a note describing the problem along with any other pertinent information and how to contact you.

Factory Service (Europe)

If factory service is required, ship the unit prepaid in its original carton to:

Telex EVI Audio GmbH

Hirschberger Ring 60

D-94315 Straubing

Telephone: +49 (0) 9421 706 0

Fax: +49 (0) 9421 706 350

Enclose a note describing the problem along with any other pertinent information and how to contact you.

For more information about service in your local area go to www.electrovoice.com.

Warranty (Limited)

Please go to www.electrovoice.com for all current warranty information.

ACCESSORIES AND PARTS

Accessories and Parts	Model #	Order #
R300-L System Uni Lapel	ULM18	F.01U.168.803
R300-E System Headworn Microphone	HM3	F.01U.168.804
Windscreen for ULM18	WS-18	F.01U.168.802
Windscreen for HM3	WS-H3	F.01U.170.778
Beltclip for BP-300	BC-300	F.01U.168.797
Guitar Cord	MAC-G3	F.01U.118.492
PL22 Dynamic Mic Head	RCC-PL22	F.01U.170.777
Foam Windscreen for Handheld	379-1	F.01U.117.911
½ Wave Receiver Antenna A Band	CRA-A	F.01U.168.794
½ Wave Receiver Antenna B Band	CRA-B	F.01U.168.795
½ Wave Receiver Antenna E Band	CRA-E	F.01U.168.796
Single Receiver Rack Mount Kit	RMS-300	F.01U.168.792
Double Rack Mount Kit	RMD-300	F.01U.168.793
Front mount antenna cables (4)	FMC-K	F.01U.118.471
ANTENNA/PWR DISTRIBUTION (520-760 MHz) (A/B)	APD4+	F.01U.117.678
ANTENNA/PWR DISTRIBUTION (760-865 MHz) (E Band)	APD4+Euro	F.01U.117.679
TERMINATION PLUG FOR APD4+	TP-2	F.01U.086.103

APPENDIX A COMPATIBLE CHANNEL GROUPS

(Use only channels within the same group when using more than two R300 units in one room.
If you need additional help call 1-800-392-3497 (US and Canada only).

US/EURO Band A 618-634 MHz							
Group 1		Group 2		Group 3		Group 4	
Channel	Freq	Channel	Freq	Channel	Freq	Channel	Freq
1	618.500	9	618.900	17	619.300	25	619.700
2	622.700	10	620.100	18	620.500	26	620.900
3	624.400	11	621.500	19	621.900	27	622.300
4	628.300	12	623.100	20	623.500	28	623.900
5	628.800	13	624.900	21	625.300	29	625.700
6	630.700	14	626.925	22	627.325	30	627.725
7	631.400	15	629.325	23	629.725	31	630.125
8	633.500	16	632.075	24	632.475	32	632.875

APPENDIX A COMPATIBLE CHANNEL GROUPS

US/EURO Band B 678-694 MHz							
Group 1		Group 2		Group 3		Group 4	
Channel	Freq	Channel	Freq	Channel	Freq	Channel	Freq
1	678.500	9	678.900	17	679.300	25	679.700
2	682.700	10	680.100	18	680.500	26	680.900
3	684.400	11	681.500	19	681.900	27	682.300
4	688.300	12	683.100	20	683.500	28	683.900
5	688.800	13	684.900	21	685.300	29	685.700
6	690.700	14	686.925	22	687.325	30	687.725
7	691.400	15	689.325	23	689.725	31	690.125
8	693.500	16	692.075	24	692.475	32	692.875

APPENDIX A COMPATIBLE CHANNEL GROUPS

Euro Band E 850-865 MHz							
Group 1		Group 2		Group 3		Group 4	
Channel	Freq	Channel	Freq	Channel	Freq	Channel	Freq
1	850.400	9	850.800	17	851.200	25	850.000
2	851.600	10	852.000	18	852.400	26	854.200
3	853.000	11	853.400	19	853.800	27	855.900
4	854.600	12	855.000	20	855.400	28	859.800
5	856.400	13	856.800	21	857.200	29	860.300
6	858.425	14	858.825	22	859.225	30	863.100
7	860.825	15	861.225	23	861.625	31*	865.000
8*	863.575	16*	863.975	24	864.375	32	–

*Channels 8, 16 and 32 can be used as a group alone in the deregulated band.

Headquarters in Americas and Asia and Pacific Rim addresses

Americas:

Headquarters Americas
Bosch Security Systems, Inc.
12000 Portland Ave South,
Burnsville, MN 55337, USA
USA—Ph: 1-800-392-3497
Fax: 1-800-955-6831

Canada:

Ph: 1-866-505-5551
Fax: 1-866-336-8467

Latin America:

Ph: 1-952-887-5532
Fax: 1-952-736-4212

Europe, Africa & Middle-East:

Headquarters EMEA
EVI Audio GmbH
Sachsenring 60,
94315 Straubing, Germany
Phone: +49 9421 706-0,
Fax: +49 9421 706-265

UK:

Shuttlesound,
4 The Willows Centre,
Willow Lane, Mitcham,
Surrey CR4 4NX, UK
Phone: +44 208 646 7114
Fax: +44 208 254 5666

Asia & Pacific Rim:

Headquarters Asia
Telex Communications (SEA) Pte Ltd
38C Jalan Pemimpin
Singapore 577180
Tel: (65) 6319 0616
Fax: (65) 6319 0620

Japan:

EVI Audio Japan, Ltd
5-3-8 Funabashi, Setagaya-ku,
Tokyo 156-0055
Tel: +81 (3) 5316-5021
Fax: +81 (3) 5316-5031

Hong Kong:

Telex EVI Audio (Hong Kong) Ltd.
Room 508-509, 5/F,
Topsail Plaza
11 On Shum Street
Shek Mun, Shatin HK
Phone: +852 2351-3628,
Fax: +852 2351-3329

Shanghai:

Telex EVI Audio (Shanghai) Co., Ltd.
Room 3105-3109,
Tower 1 Office Building,
218 Tian Mu Xi Rd.,
Shanghai, China
Postal Code: 200070
Tel: +86 21-6317-2155
Fax : +86 21-6317-3025