

# User Guide

**HOT SPOT®, HOT SPOT VC®,  
MICRO SPOT VC, POWERED  
HOT SPOT, POWERED MICRO SPOT**



## TABLE OF CONTENTS

IMPORTANT SAFETY INSTRUCTIONS.....	1
WELCOME.....	2
BEFORE YOU BEGIN.....	2
OHM'S LAW AND THE <b>HOT SPOT</b> .....	3
SOUND REINFORCEMENT BASICS.....	5
<b>HOT SPOT SERIES/MICRO SPOT VC</b> .....	6
<b>POWERED HOT SPOT/POWERED MICRO SPOT</b> .....	8
USING THE <b>PA5XD</b> .....	8
USING THE <b>HOT SPOT</b> WITH THE <b>PA5XD</b> .....	10
<b>POWERED MICRO SPOT MSPA/MSPA-DC</b> .....	11
STAND MOUNTING.....	12
MOUNTING YOUR <b>MICRO SPOT</b> SERIES SPEAKERS.....	13
SPECIFICATIONS.....	17
WARRANTY.....	19
REGISTRATION.....	22

## **IMPORTANT SAFETY INSTRUCTIONS**

1. Read these instructions.
2. Keep these instructions.
3. Heed all warnings.
4. Follow all instructions.
5. Do not use this apparatus near water.
6. Clean only with dry cloth.
7. Do not block any ventilation openings. Install in accordance with the manufacturer's instructions.
8. Do not install near any heat sources such as radiators, heat registers, stoves, or other apparatus (including amplifiers) that produce heat.
9. Do not defeat the safety purpose of the polarized or grounding-type plug. A polarized plug has two blades with one wider than the other. A grounding type plug has two blades and a third grounding prong. The wide blade or the third prong are provided for your safety. If the provided plug does not fit into your outlet, consult an electrician for replacement of the obsolete outlet.
10. Protect the power cord from being walked on or pinched particularly at plugs, convenience receptacles, and the point where they exit from the apparatus.
11. Only use attachments/accessories specified by the manufacturer.
12. Use only with the cart, stand, tripod, bracket, or table specified by the manufacturer, or sold with the apparatus. When a cart is used, use caution when moving the cart/apparatus combination to avoid injury from tip-over.



13. Unplug this apparatus during lightning storms or when unused for long periods of time.
14. Refer all servicing to qualified service personnel. Servicing is required when the apparatus has been damaged in any way, such as power-supply cord or plug is damaged, liquid has been spilled or objects have fallen into the apparatus, the apparatus has been exposed to rain or moisture, does not operate normally, or has been dropped.
15. Do not expose this apparatus to dripping or splashing and ensure that no objects filled with liquids, such as vases, are placed on the apparatus.
16. To completely disconnect this apparatus from the AC Mains, disconnect the power supply cord plug from the AC receptacle.
17. The mains plug of the power supply cord shall remain readily operable.



The lightning flash with arrowhead symbol within an equilateral triangle, is intended to alert the user to the presence of uninsulated "dangerous voltage " within the product's enclosure that may be of sufficient magnitude to constitute a risk of electric shock to persons.



The exclamation point within an equilateral triangle is intended to alert the user to the presence of important operating and maintenance (servicing) instructions in the literature accompanying the product.

**WARNING:** To reduce the risk of fire or electric shock, do not expose this apparatus to rain or moisture.

# Welcome

Congratulations on your purchase of a Galaxy Audio Product! Backed by over 25 years of proven real-world performance and a 3 year warranty, the product you have selected is one of the finest personal monitoring devices available. Thank you for choosing Galaxy Audio.

For full specifications of Galaxy Audio products, visit [www.galaxyaudio.com](http://www.galaxyaudio.com)

## Fill this out and retain for your records

Model: \_\_\_\_\_

Serial number: \_\_\_\_\_

Purchased from: \_\_\_\_\_

Purchase date: \_\_\_\_\_





To contact Galaxy Audio call 1-800-369-7768  
write to P.O. BOX 16285 Wichita, Ks 67216-0285  
or visit [www.galaxyaudio.com](http://www.galaxyaudio.com)

**CAUTION: THESE PRODUCTS ARE CAPABLE OF PRODUCING SOUND PRESSURE LEVELS WHICH MAY CAUSE PERMANENT HEARING DAMAGE AFTER PROLONGED EXPOSURE.**



### BEFORE YOU BEGIN

Before using this product be sure to read and understand all instructions in this manual pertaining to the model(s) you have purchased.

### DO...

-  Read this manual
-  Use a unidirectional microphone
-  Handle with care
-  Complete the registration card at the back of the manual

### DON'T...

-  Expose any unit covered in this manual to rain or moisture
-  Plug-in or unplug the **HOT SPOT** while it is operating (doing so may damage your amplifier)
-  Attempt to make any repairs yourself (call Galaxy Audio for repairs). Failure to do so may void your warranty.

# OHM'S LAW AND THE HOT SPOT

All unpowered HOT SPOTS have a 16 ohm impedance, and like most professional-type speakers have jacks which are wired in parallel (meaning the signal can travel into one jack and out of the other). Think of each speaker as a "load" added to the amplifier. The greater the number of speakers, the heavier the load. Adding too many speakers can overload the amplifier, causing it to overheat and distort. If the amplifier begins to distort, or if it becomes hot to the touch, disconnect any extra speakers. One easy way to determine the load on the amplifier is to use Ohm's law, which states: "The total impedance of  $N$  speakers in parallel is equal to the reciprocal of the sum of the reciprocals." In equation form:

Where  $Z_1$  is the impedance (or ohm rating) for the first speaker,  $Z_2$  for the second, and so on, for every speaker in the chain. This equation calculates the total impedance of the speaker system, which should **NOT** be lower than the minimum impedance rating of the amplifier.

$$Z(\text{Total}) = \frac{1}{\frac{1}{Z_1} + \frac{1}{Z_2} + \frac{1}{Z_3} + \frac{1}{Z_4} + \frac{1}{Z_N}}$$

## EXAMPLE 1:

For one pair of speakers use the short form of the equation: the product of the two speakers divided by the sum of the two speakers is equal to the total impedance or the equivalent impedance of the speaker system.

$$Z = \frac{Z_1 \times Z_2}{Z_1 + Z_2}$$

This equation may be used to calculate the equivalent impedance for additional speakers in two-speaker increments. Determine the impedance of the first two speakers, substitute  $Z$  total for  $Z$ , and include the next speaker. Repeat the process until all speakers have been included. The result should be the same as with the first method. A word of caution: polarity rules must be observed when connecting multiple speakers. Polarity will not affect the  $Z$ , but can

affect the quality and volume of the sound. If you are having problems with any of these applications use Galaxy Audio's CRICKET Polarity and Continuity Test Set to check the polarity of your cables.

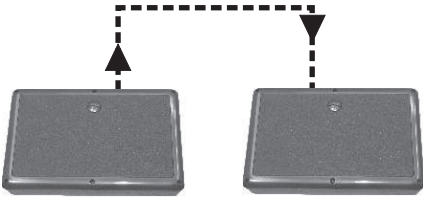

$$Z = \frac{16 \times 16}{16 + 16} = 8 \text{ Ohms for two HOT SPOTS}$$

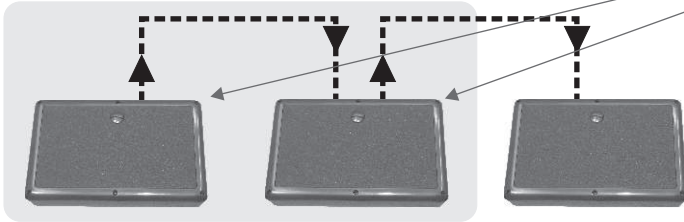

$$Z = \frac{8 \times 16}{8 + 16} = 5.33 \text{ Ohms for three HOT SPOTS}$$

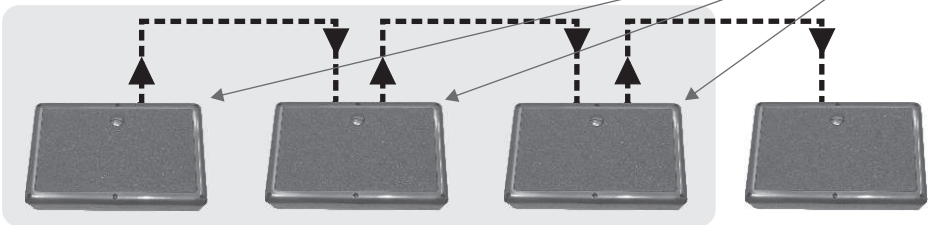

$$Z = \frac{5.33 \times 16}{5.33 + 16} = 4 \text{ Ohms (the total load)}$$

**EXAMPLE 2:**



As long as all of the speakers have the same impedance rating, the equivalent impedance of the system is the rated impedance of one speaker divided by the number of equivalent speakers.

# SOUND REINFORCEMENT BASICS

## Avoiding feedback

*Feedback* (the shriek sometimes emitted by PA systems) occurs when the microphone (or pickup) and speaker are positioned too close together for a given level of volume. Once feedback occurs, it will continue until either the volume is decreased or the microphone or speaker is moved. *Gain* is the degree to which the volume may be turned up before feedback begins. In setting up a sound system, the objective is to maximize gain.

## Monitor Placement

-  **HOT SPOT**® Monitors should be positioned within arm's reach of the performer.
-  Monitors should be placed to the rear of the microphone being used by the performer.

## Avoiding Distortion

Distortion in a monitor system usually occurs when the amplifier is being over-driven, nearing the limits of its power output capability. Over-driving the amplifier may be corrected by reducing the bass frequencies in the monitor mix (low notes use a lot of power). Since the HOT SPOT NEOLITE driver will not reproduce tones lower than 200 Hz, reduce the low frequencies if the speaker begins to distort. Distortion may also originate with a bad signal source.

## NEO DRIVER

Introduced in 2004, the NEOLITE® driver is a state of the art controlled bandwidth speaker that is included in all products covered in this manual with the exception of the MSPA/MSPA-DC. Tailored to reproduce a frequency range from 150 Hz-18 kHz, the NEOLITE® is manufactured with the rare earth element Neodymium that has an extremely intense magnetic field in comparison to its weight. This magnetic field is also very concentrated, allowing the speaker to be placed near sensitive equipment that may be affected by a strong magnetic force, such as a TV or a computer monitor.



## **HOT SPOT® SERIES/MICRO SPOT VC**

HSRG/HSVC The HOT SPOT was created as the solution to the problem of musicians and public speakers not being able to hear themselves while performing. The HOT SPOT's design is unsurpassed in efficiently reproducing the crucial vocal range frequencies from 150Hz to 18 kHz.

Each Hot Spot comes with a built in stand mount that allows the unit to be placed on nearly any microphone stand, close to the performer, for true near field vocal monitoring (some microphone stands may require the optional stand adaptor SA-1)

The Hot Spot VC (HSVC) comes with a volume control that not only affects the volume of the unit, but also the impedance of the unit. (See chart [T.1] pg.7 for more information about the volume control).

### **MSVC**

Like the Hot Spot series, the Micro Spot VC is also tailored to the vocal frequencies. The Micro Spot can be mounted to a microphone stand using the included yoke bracket kit. For information regarding the bracket kit see, MOUNTING YOUR MICRO SPOT SERIES SPEAKERS. [A.1](pg. 13)

Like the Hot Spot VC, the Micro Spot VC is also equipped with a volume control. (Please refer to table [T.1] pg. 7 for information regarding the positions on the volume control).

# The HOT SPOT VC and MICRO SPOT VC

The impedance of the **HOT SPOT VC** and **MICRO SPOT VC** is determined by the position of its volume control. Use the table below to determine the actual impedance.

[T.1]

POSITION	IMPEDANCE	dB REDUCTION
Full Clockwise	16 ohms	0
2nd	23 ohms	-3
3rd	33 ohms	-6
4th	46 ohms	-9
5th	64 ohms	-12
6th	90 ohms	-15
7th	130 ohms	-18

**Note:** Each Hot Spot VC comes equipped with a Speakon® and two 1/4" speaker jacks, all of which are wired in parallel to allow easy "daisy chaining" of multiple Hot Spots. The aluminum screw-on jack caps on the 1/4" jacks should remain in place when those jacks are not in use to keep the cabinet airtight and to avoid any unwanted "whistling"

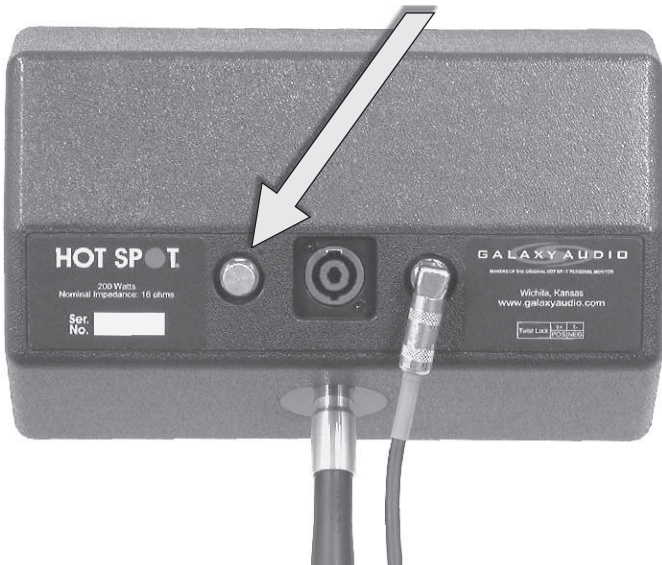



## POWERED HOT SPOT/POWERED MICRO SPOT FEATURES OF GALAXY AUDIO'S POWERED SPEAKERS

PA5XD (CUL Listed), MSPA/MSPA-DC (CSA US listed)

Black cast aluminum faceplate (used as an integral heat sink)

Fire-retardant styrene plastic outer shell

SmartALIC (PA5XD only) input circuitry automatically distinguishes between microphone and line level signals without having to flip a switch.

### Using the PA5XD as a...

#### Powered Monitor



When connected to a mixer's monitor output or auxiliary output, the **PA5XD** enables each performer to create his/her own monitor mix.



Additional monitors can be attached to the **PA5XD**'s speaker output.



A recorder can be attached to the **PA5XD**'s LINE output.



Virtually any type of signal (instrument, mic level from a mixing console, guitar, keyboard, tape player or condenser mic can be plugged into the **PA5XD** inputs.

#### Ultra-Compact PA System



The **PA5XD** by itself is a one-piece PA system. Simply plug in a mic or instrument for 100 watts of sound reinforcement power.



When two 16 ohm Galaxy Audio **HOT SPOT**® personal monitors are attached to the SPEAKER OUTPUT, the **PA5XD**'s power output increases to 146 watts. Whether using the HOT SPOT or another speaker, the **PA5XD**'s power output depends on the impedance of the speakers being powered. The load on the **PA5XD**'s amplifier section must be greater than or equal to 4 ohms. Anything less will overload the amplifier.

#### Practice Amp



A balanced signal from a microphone or second instrument may be fed into one input while an instrument, CD player or tape deck is fed into the other.



Effects devices for microphones or a second instrument may be fed into one input while an instrument, CD player or tape deck is fed into the other.

## The PA5XD (POWERED HOT SPOT) CONTROLS/INDICATORS and their operation (Front Panel)

LEVEL CONTROL FOR MIC (XLR) INPUT

LEVEL CONTROL FOR 1/4" INPUT

POWER SWITCH



### TONES CONTROLS

When all three controls are set to the 12 o'clock (detent) position, the output frequency response is flat.

**HIGH** +/- 12dB shelving at 15 kHz

**MID** +/- 10dB peak/dip at 2 kHz

**LOW** +/- 10dB peak/dip at 300 Hz

### MIC (XLR) INPUT

Balanced input with 24 VDC phantom power for electret microphones.

1/4" INPUT

POWER LED

### LIMIT LED

Indicates when the built-in compression circuit is activated. By automatically reducing gain before clipping occurs the compression circuit prevents distortion. The LIMIT LED remains lit about half the time when the amplifier is being driven to its maximum potential. Do not allow it to remain lit more than half the time.

## CONNECTORS/INDICATORS and their operation (Rear Panel)

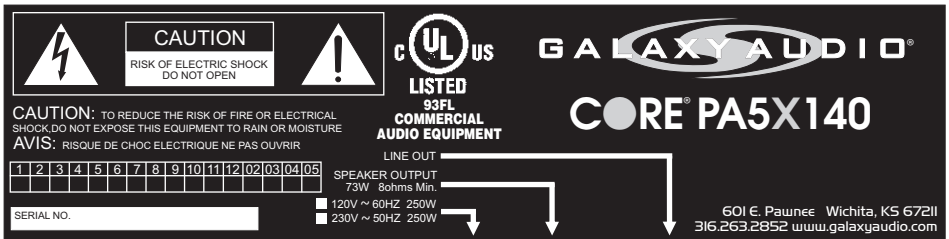

POWER CORD

### SPEAKER OUTPUT

1/4" connector output from the internal amplifier. It can supply an external 8 ohm speaker with 73 watts of RMS power. This means two 16 ohm HOT SPOTS can be connected to the system without overloading the amplifier; great for a small PA or monitor setup.

### LINE OUT

RCA jack -10dB line level output can be fed to a recorder, or to other sound system components. It is post-EQ, pre-compressor and pre-amplifier.

## USING THE HOT SPOT® WITH THE PA5XD POWERED MONITOR

---

The PA5XD's SPEAKER OUTPUT jack is designed to allow a maximum of two HOT SPOTS to be "daisy-chained" to it.

**The PA5XD produces 146 watts when powering two HOT SPOTS (see figure below)**

Route cables:

- 1) From the microphone to Galaxy Audio's PA5XD.
- 2) From the output of the PA5XD to the first HOT SPOT.
- 3) From the first HOT SPOT to the second HOT SPOT.

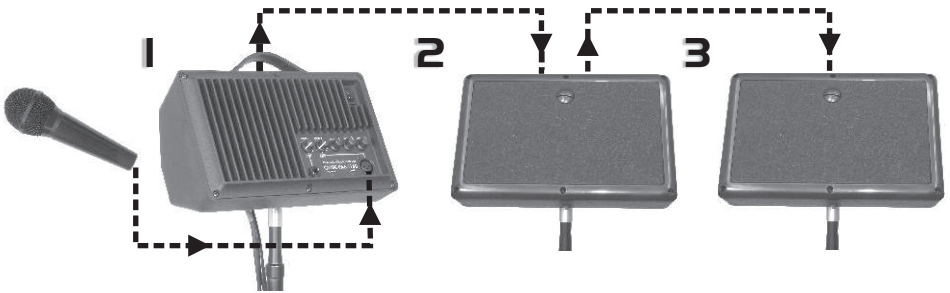

# POWERED MICRO SPOT

MSPA/MSPA-DC



The MSPA is similar to the Powered Hot Spot, with one major difference; it's half the size! The MSPA has a 30 watt amplifier, with a universal power supply. That means this unit can be used anywhere in the world as it will function on 90-250 VAC (volts AC) at 50/60 Hz. The MSPA delivers full frequency fidelity thanks to its full range 4.5" speaker.

In addition to the standard AC input, MSPA-DC comes equipped with a 12volt DC input. When AC power is not available, the MSPA-DC can be plugged into a car's cigarette lighter, using the included cable, or attached directly to a 12 volt battery using the optional clamp cable. 12volt interface cables can be purchased from any authorized dealer or at [www.galaxyaudio.com](http://www.galaxyaudio.com).

For information regarding stand or wall mounting, see **MOUNTING YOUR MICRO SPOT SERIES SPEAKERS**. (Page. 13)

## CONTROLS/INDICATORS and their operation (Front Panel)

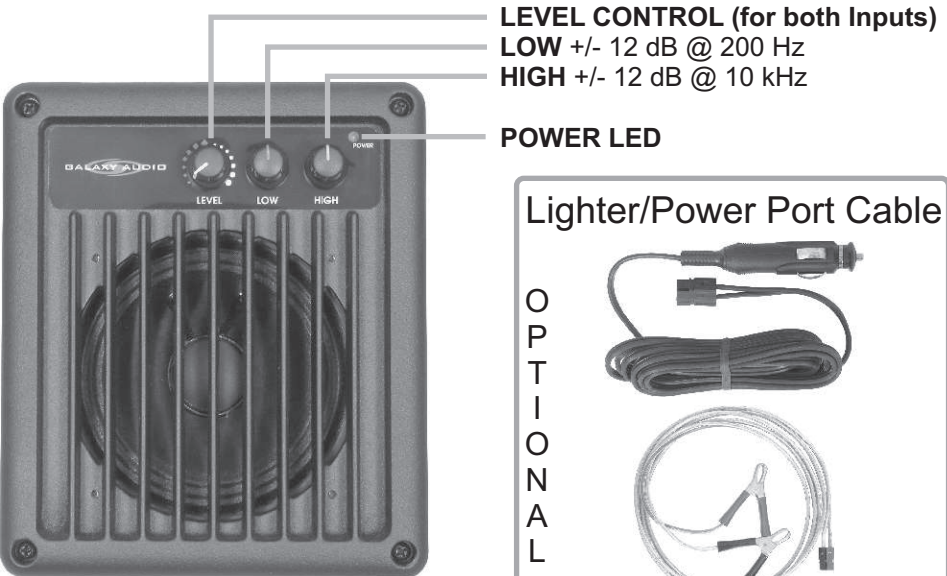

**CONTROLS/INDICATORS** and their operation (Rear Panel)

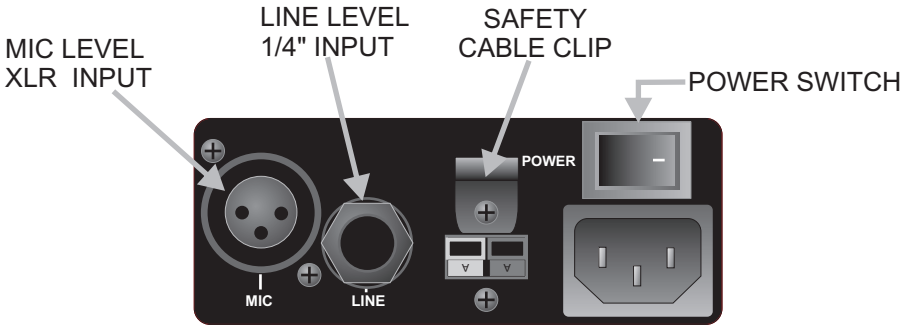

**MSPA-DC**  
label shown  
**MSPA**  
label  
excludes  
DC input

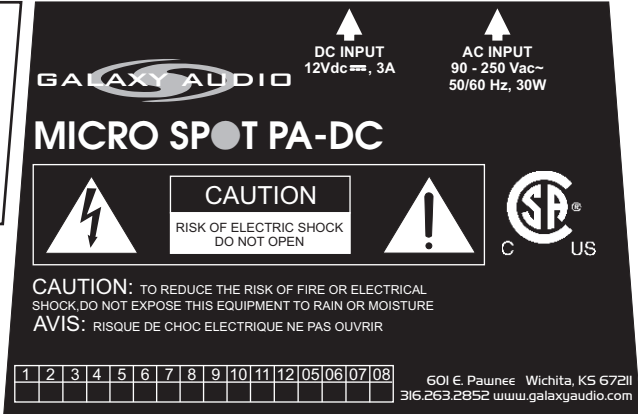

**STAND MOUNTING**

All HOT SPOT's, both powered and un-powered, have a built in microphone stand mount: just slide the microphone stand into the receptacle on the bottom of the HOT SPOT. Some microphone stands may require an adaptor (contact any Galaxy Audio dealer and ask for an SA-1, microphone stand adaptor).

**THE SA-1 WILL ALLOW YOU TO SECURELY PLACE YOUR HOT SPOT ON ANY MICROPHONE STAND.**



# MOUNTING YOUR MICRO SPOT SERIES SPEAKERS

The Micro Spot VC comes equipped with a stand mount bracket kit, while the Powered Micro Spot is supplied with a bracket kit that allows either stand or wall mounting. Wall mount options are available for the Micro Spot VC from any Galaxy Audio dealer, or online at [www.galaxyaudio.com](http://www.galaxyaudio.com)

## Stand Mounting

To install the yoke bracket, attach the SA-1 to the yoke bracket using the included 1/4-20 hex bolt and washer as shown in picture below (A.1). Tighten using a 7/16 wrench or socket. The yoke bracket assembly can now be screwed on to the microphone stand. Remove the two plastic threaded inserts from the T-nuts in each side of the Micro Spot with a small flat blade screwdriver. Place the Micro Spot into position so that the wing screws at the ends of the yoke line up with the T-nuts in the cabinet. Tighten the wing screws by hand.

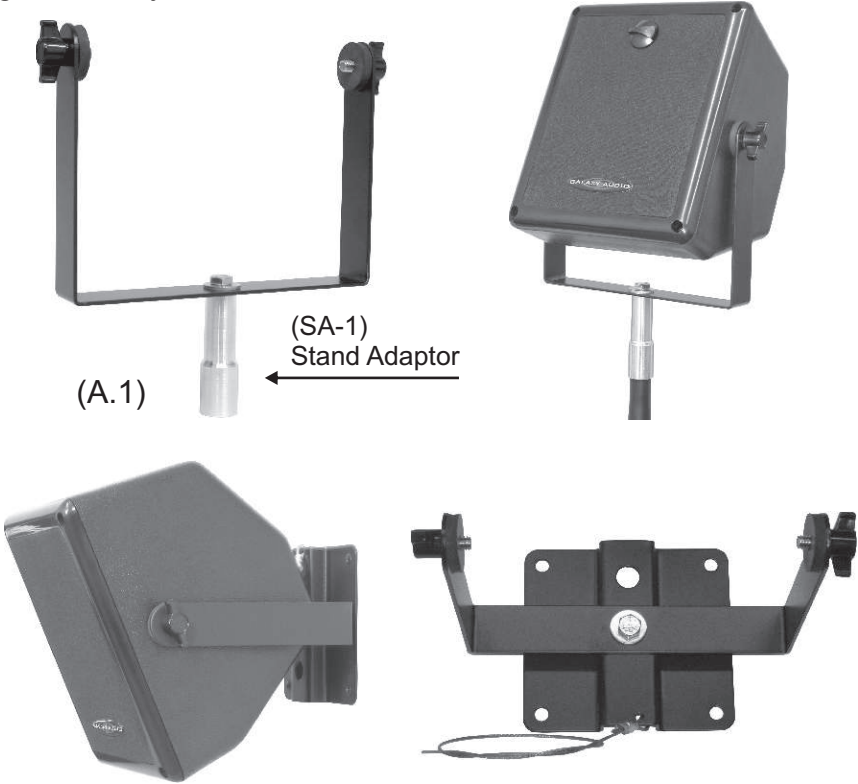

## WALL/CEILING MOUNTING

Galaxy Audio yoke brackets can be used for permanently mounting HOT SPOT, MICRO SPOT, and CHAMELEON loudspeakers to walls and ceilings. The mounting angle can be adjusted by simply loosening the wing screws at either end of the yoke and by loosening the bolt where the yoke mounts to the wall plate. These brackets should be used only on a flat, secure, and stable surface.

### **PRECAUTIONS:**

Whenever an object is affixed to a wall or ceiling, you must take special care to mount it securely to prevent it from falling and causing damage or injury.

**MOUNTING SURFACES:** Carefully examine the composition, construction and strength of the surface you are mounting to. Be sure to provide adequate reinforcement should you deem it necessary. You must also consider what type of hardware and what type of mounting techniques are appropriate for each mounting surface.

**FASTENERS:** Attaching the bracket requires fasteners selected for the strength and composition of the mounting surfaces involved. Whatever fastener is selected, it should be no smaller than a #8 screw or 1/4" bolt. When drilling pilot holes be sure that the holes are smaller than the core diameter of the screw. Always use fasteners in all mounting holes and avoid over tightening, as this can weaken the mounting surface, damage the fasteners, and make the installation much less secure.

**SECONDARY SUPPORT:** As we recommend the use of a secondary support for added safety, each yoke bracket is equipped with a safety cable. When properly installed it provides secondary support without inhibiting the adjustment of the bracket, and can be easily hidden out of sight.

## **MOUNTING PROCEDURE:**

**PREVIEW:** After evaluating the mounting surfaces and obtaining the appropriate fasteners, the installation will consist of the following steps, in order:

1. Mounting the bracket plate to the wall or ceiling.
2. Bolting the yoke to the plate.
3. Joining the cabinet with the bracket assembly.
4. Installing the safety cable.
5. Adjusting the speaker position and tightening the yoke bolt and wing screws.

**TOOLS REQUIRED:** You will need at least these tools for installation:

- 7/16" box end wrench
- large crimping pliers
- tools to secure the fasteners selected for the bracket assembly (drill, screwdrivers, etc.)
- carpenter's level for precise positioning of the speaker. (optional)

**Note:** It is often helpful to have another person available to hold the speaker in place during the tightening procedure.

## **INSTALLATION:**

### **ATTACHING THE BRACKET ASSEMBLY TO THE MOUNTING SURFACE:**

Position the bracket assembly onto the wall or ceiling at the location you have selected, preferably to a stud, joist or other structural member rather than only to drywall or other non-structural material. Make sure there will be enough clearance to rotate and tilt the speaker to the desired angle. Using the base plate of the bracket assembly as a template, mark the four hole locations.

**NOTE:** Check that any holes you drill and the fasteners will not interfere with any wiring, plumbing, etc. that may be behind the mounting surface.

Prepare the mounting surface and the four holes for the fasteners.

Pull speaker wires through the mounting surface and the feed thru the hole in the bracket. Secure the bracket base plate. Do not over tighten fasteners! Bolt the yoke to the base plate and tighten with a 7/16" box end wrench.

### **JOINING THE CABINET TO THE BRACKET ASSEMBLY:**

Remove the two plastic threaded inserts from the T-nuts with a small flat blade screwdriver. Lift the speaker into position so that the wing screws at the ends of the yoke line up with the T-nuts in the cabinets. Tighten the wing screws by hand.

### **SECURING THE SAFETY CABLE:**

Slip the loose end of the safety cable through the cable clamp located at the back of the cabinet. Bring the cable back through the crimp sleeve and firmly crimp the sleeve with a large pair of crimping pliers.

### **ADJUSTMENT:**

Loosen the yoke bolt just enough to slide or rotate the yoke to the desired position. Tighten the yoke bolt securely with a 7/16" box end wrench. If necessary loosen the wing screws and tilt the Hot Spot to the desired position. Re-tighten the wing screws firmly by hand. After a few minutes check the assembly for any slippage and re-tighten. Connect the speaker wires and the installation is complete.

# SPECIFICATIONS

	HOT SPOT®	HOT SPOT VC	MICRO SPOT VC
Speaker Compliment	2- 5" drivers (S5N-8)	2- 5" drivers (S5N-8)	1- 5" driver (S5N-16)
Magnet Structure	14.8 oz. (.42 kg) total	14.8 oz. (.42 kg) total	7.4 oz. (.21 kg)
Power Handling	200 watts cont.	200 watts cont.	100 watts cont.
Sensitivity (1 watt @ 1 meter)	92 dB (1 kHz octave band)	92 dB (1 kHz octave band)	92 dB (1 kHz octave band)
Frequency Response	150 Hz- 18 kHz	150 Hz- 18 kHz	150 Hz- 18 kHz
Nominal Impedance	16 ohms	16 ohms	16 ohms
Input Connections	1/4" jacks, Speakon® (in parallel)	1/4" jacks, Speakon® (in parallel)	1/4" jacks
*SPL OWT	28	28	43.37
Enclosure	ABS Plastic	ABS Plastic	Fire Retardant Styrene
Dimensions	6.75" x 10.94" x 6" (171mm x 278mm x 152mm)	6.75" x 10.94" x 6" (171mm x 278mm x 152mm)	7" x 6" x 5.125" (178mm x 152mm x 130mm)
Net Weight	4.5 lbs. (2.04kg)	4.5 lbs. (2.04kg)	2.7 lbs. (1.23kg)
Additional Feature		volume control; range 18 dB	volume control; range 18 dB

The Galaxy Audio SSN-8 and SSN-16 are ferro fluid cooled drivers.

**Ferrosound**  
The Solution is Loud And Clear.™

\***Splowt** A unit of measure, expressed as dB, that divides a speaker's maximum SPL by its weight in pounds. Galaxy Audio's MICRO SPOT boasts a splowt of 43 dB (highest in the known universe).

# SPECIFICATIONS

## MSPA/MSPA-DC

## PA5XD

Power Output	30 watts @ 4 ohms	100 watts @ 8 ohms 146 watts @ 4 ohms
Distortion	<0.5% @ 4 ohms	8 ohm < 0.05%, 4 ohm < 0.1%
Minimum Load	4 ohms	4 ohms
Frequency Response	200 Hz- 15 kHz	200 Hz- 18 kHz
Equalization	Two band center detent LOW: +/-12 dB @ 200 Hz HIGH: +/-12 dB @ 10 kHz	three band center detent LOW: +/-10 dB @ 300 Hz MID: +/-10 dB @ 2 kHz HIGH: +/-12 dB @ 15 kHz
Input Connections	one 1/4-inch balanced one XLR w/+15VDC Phantom	one 1/4-inch balanced one XLR 24V Phantom PWR
Output Connections		one 1/4-inch for 8 ohm load one RCA line out
Power Requirements	<b>MSPA-DC</b> 90-250 Vac~ 50/60 Hz, 30W 12Vdc ==, 3A  <b>MSPA</b> 90-250 Vac~ 50/60 Hz, 30W	DOMESTIC: 120Vac~ 60Hz  EXPORT: 230Vac~ 50Hz
Speaker Compliment	1- 4.5" driver, 4 ohms	1- 5" driver (S5N-8), 8 ohms
*SPLOWT	21	9.12
Enclosure	Fire Retardant Styrene	Fire Retardant Styrene
Dimensions	7"x 6"x 5.125" (178mm x 152mm x 130mm)	6.75"x 10.94"x 6" (171mm x 278mm x 152mm)
Net Weight	4.82 lbs. (2.19kg)	10.7 lbs. (4.85kg)

The Galaxy Audio S5N-8 and S5N-16 are ferro fluid cooled drivers.

**Ferrosound**  
The Solution is Loud And Clear™

\***Splowt** A unit of measure, expressed as dB, that divides a speaker's maximum SPL by its weight in pounds. Galaxy Audio's MICRO SPOT boasts a splowt of 43 dB (highest in the known universe).

# THREE YEAR LIMITED WARRANTY

This warranty gives you specific legal rights, and you may also have other rights which may vary from state to state. This warranty is extended to the purchaser and to any purchaser from him for value.

GALAXY AUDIO warrants the materials and workmanship of its products for a period of three full years from the date of the original purchase.

The following are not covered by the warranty:

1. Damage to or deterioration of the exterior cabinet which occurs after delivery.
2. Damage after initial delivery resulting from accident, misuse or neglect.
3. Damage resulting from failure to follow instructions contained in the owner's manual.
4. Damage resulting from the performance of repairs by someone other than GALAXY AUDIO or an authorized GALAXY AUDIO service center.
5. Damage occurring during the shipment or delivery of any GALAXY AUDIO product to GALAXY AUDIO or an authorized service center after initial delivery of the product to you.
6. Damage to any GALAXY AUDIO product which has been altered, or on which the serial number has been effaced or removed.

If your unit requires service, it must be returned, shipping charges prepaid to an authorized GALAXY AUDIO service center in the United States. (This warranty is not enforceable outside the U.S.) If you are not able to locate an authorized service center in your area, please call or write GALAXY AUDIO, 601 E.Pawnee, Wichita, Kansas 67211, (316) 263-2852. We will then refer you to an authorized service center to which the unit may be returned, or we may advise you to return your unit to the factory for service. Under no circumstances should you return your unit to the factory without written instruction to do so. If service is required, you must present the original or a copy of the bill of sale as a proof of date of purchase of your unit. Upon receipt of your unit for service, GALAXY AUDIO or the authorized service center will repair or replace your unit as soon as possible, but in no event later than 30 days after the receipt of the unit. We will return the unit to you, shipping charges prepaid, provided the necessary repairs are covered by this warranty. IMPLIED WARRANTIES OF MERCHANT ABILITY AND FITNESS FOR PARTICULAR PURPOSE ARE LIMITED IN DURATION TO THE LENGTH OF THIS WARRANTY, UNLESS OTHERWISE PROVIDED FOR BY STATE LAW. GALAXY AUDIO'S LIABILITY IS LIMITED TO THE REPAIR OR REPLACEMENT, AT OUR OPTION, OF ANY DEFECTIVE PRODUCT, AND SHALL IN NO EVENT INCLUDE INCIDENTAL OR CONSEQUENTIAL DAMAGES OF ANY KIND. SOME STATES DO NOT ALLOW LIMITATIONS ON HOW LONG AN IMPLIED WARRANTY LASTS AND/OR DO NOT ALLOW THE EXCLUSION OR LIMITATION OF INCIDENTAL OR CONSEQUENTIAL DAMAGES, SO THE ABOVE LIMITATIONS AND EXCLUSIONS MAY NOT APPLY TO YOU.

GALAXY AUDIO does not authorize any third party, including any dealer or Authorized Service Center, to assume any liability on behalf of GALAXY AUDIO or to make any warranty for GALAXY AUDIO.

**Four rubber feet are included for those of you using the HOT SPOT or HOT SPOT VC with the TWIST LOCK connector and as a stand alone wedge speaker.**



These rubber feet allow for extra room for the Speaker® connector and its cable.



1-800-369-7768    [www.galaxyaudio.com](http://www.galaxyaudio.com)  
P.O. BOX 16285 Wichita, Ks 67216-0285



1-800-369-7768    [www.galaxyaudio.com](http://www.galaxyaudio.com)  
P.O. BOX 16285 Wichita, Ks 67216-0285

Specifications in this manual are subject to change without notice.

# REGISTRATION CARD

Registration information is used ONLY by GALAXY AUDIO and will be kept strictly confidential.

## Registration

Name \_\_\_\_\_ Phone \_\_\_\_\_

Address \_\_\_\_\_

City, State, Zip \_\_\_\_\_

email \_\_\_\_\_

Dealer \_\_\_\_\_ PurchaseDate \_\_\_\_\_

Serial number	Model
---------------	-------

This Galaxy Audio product will be used for:

Live Sound

Church

### Recording

Home/Project Studio

Commercial Studio

Post-Production/Mastering

### Broadcast

On-Air

Production

What magazines do you read? \_\_\_\_\_

\_\_\_\_\_  
\_\_\_\_\_  
\_\_\_\_\_  
\_\_\_\_\_

How can Galaxy Audio better serve you?

\_\_\_\_\_  
\_\_\_\_\_  
\_\_\_\_\_  
\_\_\_\_\_  
\_\_\_\_\_

PLACE  
STAMP  
HERE

---

---

---

---

---

**GALAXY AUDIO**  
**P.O. BOX 16285**  
**WICHITA, KS 67216-0285**