

ULTRALINK PRO MX882

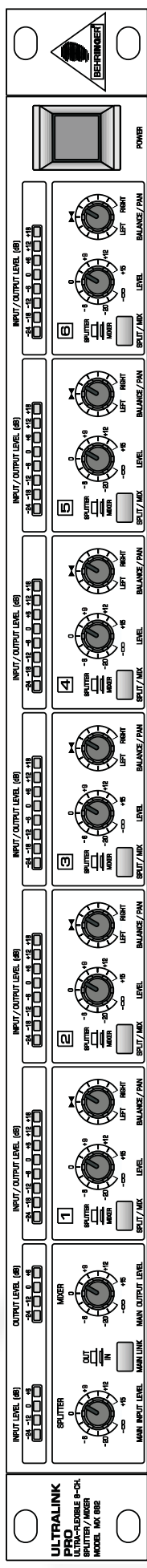

User's Manual Bedienungsanleitung

Version 1.0 July 1998



www.behringer.de



EG-Declaration of Conformity



Spezielle Studiotechnik GmbH

acc. to the Directives 89/336/EWG and 73/23/EWG

We, BEHRINGER INTERNATIONAL GmbH
Hanns-Martin-Schleyer-Straße 4
D - 47877 Willich

Name and address of the manufacturer or the introducer of the product on the market who is established in the EC

herewith take the sole responsibility to confirm that the product:

ULTRALINK PRO MX882
Type designation and, if applicable, Article-N°

which refers to this declaration, is in accordance with the following standards or standardized documents:

- | | |
|--|--|
| <input checked="" type="checkbox"/> EN 60065 | <input checked="" type="checkbox"/> EN 61000-3-2 |
| <input checked="" type="checkbox"/> EN 55020 | <input checked="" type="checkbox"/> EN 61000-3-3 |
| <input checked="" type="checkbox"/> EN 55013 | |

The following operation conditions and installation arrangements have to be presumed:

acc. to Operating Manual

BEHRINGER
INTERNATIONAL GmbH
Hanns-Martin-Schleyer-Str. 36-38
D-47877 Willich, Mercurstraße II
Tel.-Nr. 0 21 54 / 92 06-0
Fax-Nr. 0 21 54 / 92 06-30

B. Nier, President Willich, 01.07.1998

Name, address, date and legally binding signature of the person responsible

SAFETY INSTRUCTIONS

CAUTION: To reduce the risk of electrical shock, do not remove the cover (or back). No user serviceable parts inside; refer servicing to qualified personnel.



WARNING: To reduce the risk of fire or electrical shock, do not expose this appliance to rain or moisture.



This symbol, wherever it appears, alerts you to the presence of uninsulated dangerous voltage inside the enclosure - voltage that may be sufficient to constitute a risk of shock.



This symbol, wherever it appears, alerts you to important operating and maintenance instructions in the accompanying literature. Read the manual.

DETAILED SAFETY INSTRUCTIONS:

All the safety and operation instructions should be read before the appliance is operated.

Retain Instructions:

The safety and operating instructions should be retained for future reference.

Heed Warnings:

All warnings on the appliance and in the operating instructions should be adhered to.

Follow instructions:

All operation and user instructions should be followed.

Water and Moisture:

The appliance should not be used near water (e.g. near a bathtub, washbowl, kitchen sink, laundry tub, in a wet basement, or near a swimming pool etc.).

Ventilation:

The appliance should be situated so that its location or position does not interfere with its proper ventilation. For example, the appliance should not be situated on a bed, sofa rug, or similar surface that may block the ventilation openings: or placed in a built-in installation, such as a bookcase or cabinet that may impede the flow of air through the ventilation openings.

Heat:

The appliance should be situated away from heat sources such as radiators, heat registers, stoves, or other appliance (including amplifiers) that produce heat.

Power Source:

The appliance should be connected to a power supply only of the type described in the operating instructions or as marked on the appliance.

Grounding or Polarization:

Precautions should be taken so that the grounding or polarization means of an appliance is not defeated.

Power-Cord Protection:

Power supply cords should be routed so that they are not likely to be walked on or pinched by items placed upon or against them, paying particular attention to cords and plugs, convenience receptacles and the point where they exit from the appliance.

Cleaning:

The appliance should be cleaned only as recommended by the manufacturer.

Non-use Periods:

The power cord of the appliance should be unplugged from the outlet when left unused for a long period of time.

Object and Liquid Entry:

Care should be taken so that objects do not fall and liquids are not spilled into the enclosure through openings.

Damage Requiring Service:

The appliance should be serviced by qualified service personnel when:

- The power supply cord or the plug has been damaged; or
- Objects have fallen, or liquid has been spilled into the appliance; or
- The appliance has been exposed to rain; or
- The appliance does not appear to operate normally or exhibits a marked change in performance; or
- The appliance has been dropped, or the enclosure damaged.

Servicing:

The user should not attempt to service the appliance beyond that is described in the Operating Instructions. All other servicing should be referred to qualified service personnel.



ULTRALINK PRO

Ultra-flexible, multi-purpose 8-channel Signal Router for stage and studio applications

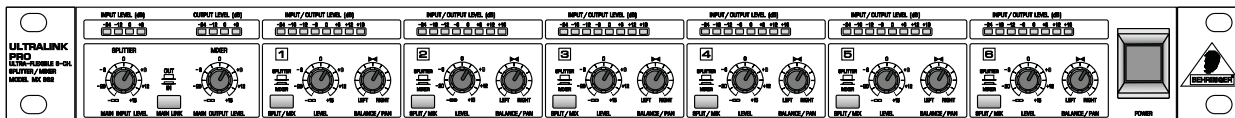

- ▲ Use it as Effects Mixer, for P.A. Monitoring, Live Sound Systems, Theaters, Conference Rooms, Hotels, Churches, etc.
- ▲ Any channel can be selected either as Mixer or Splitter
- ▲ You can use it as 8-IN, 2-OUT Line Mixer
- ▲ You can use it as 2-IN, 8-OUT Line Splitter
- ▲ You can use it as 6-IN, 6-OUT Line Driver or DI-box
- ▲ You can use it as independent line driver to convert -10 dBV into +4 dBu or vice versa
- ▲ Extremely high headroom - offering more dynamic range
- ▲ Ultra-wide bandwidth from 2 Hz to 200 kHz for “open” sound
- ▲ Offers you 6 mono inputs, 6 mono outputs, 2 main inputs and 2 main outputs
- ▲ Offers you 6 Input Level controls, 6 Balance/Pan controls, a Main Input and a Main Output control
- ▲ A Main Link switch allows you to route the Main Input to the Main Output to link several units
- ▲ Accurate 4 / 8-segment LED metering for each individual gain section
- ▲ Servo-balanced gold-plated XLR and 1/4” TRS inputs and outputs
- ▲ Completely versatile DI-Box due to servo-balanced inputs and outputs
- ▲ Ultra-low noise 4580 audio operational amplifiers for outstanding sound performance
- ▲ High-quality detented potentiometers and illuminated switches
- ▲ Manufactured under the stringent ISO9000 management system

FOREWORD

Dear Customer,

Welcome to the team of ULTRALINK PRO users and thank you very much for expressing your confidence in BEHRINGER products by purchasing this unit.

It is one of my most pleasant tasks to write this letter to you, because it is the culmination of many months of hard work delivered by our engineering team to reach a very ambitious goal: making an outstanding device better still. The ULTRALINK has for quite a long time been a standard tool used by numerous studios and P.A. rental companies. The task to improve one of our best-selling products certainly meant a great deal of responsibility, which we assumed by focusing on you, the discerning user and musician. It also meant a lot of work and night shifts to accomplish this goal. But it was fun, too. Developing a product usually brings a lot of people together, and what a great feeling it is when everybody who participated in such a project can be proud of what we've achieved.

It is our philosophy to share our joy with you, because you are the most important member of the BEHRINGER family. With your highly competent suggestions for new products you've greatly contributed to shaping our company and making it successful. In return, we guarantee you uncompromising quality (manufactured under ISO9000 certified management system) as well as excellent technical and audio properties at an extremely favorable price. All of this will enable you to fully unfold your creativity without being hampered by budget constraints.

We are often asked how we can make it to produce such high-grade devices at such unbelievably low prices. The answer is quite simple: it's you, our customers! Many satisfied customers means large sales volumes enabling us to get better conditions of purchase for components, etc. Isn't it only fair to pass this benefit back to you? Because we know that your success is our success, too!

I would like to thank all people whose help on "Project ULTRALINK PRO" has made it all possible. Everybody has made very personal contributions, starting from the designers of the unit via the many staff members in our company to you, the user of BEHRINGER products.

My friends, it's been worth the trouble!

Thank you very much,

A handwritten signature in black ink, appearing to read 'U. Behringer', with a long horizontal flourish extending to the right.

Uli Behringer



TABLE OF CONTENT

1. INTRODUCTION	7
2. THE DESIGN CONCEPT	8
2.1 High quality components and design	8
2.2 Inputs and outputs	8
2.2.1 Balanced inputs and outputs	8
3. INSTALLATION	8
3.1 Rack mounting	8
3.2 Mains voltage	8
3.3 Audio connections	8
4. CONTROLS	10
4.1 The front panel control elements	10
4.2 The rear panel elements	11
5. BLOCK DIAGRAM	12
6. APPLICATIONS	13
6.1 Application as a mixer	13
6.2 Application as a splitter	14
6.2.1 The ULTRALINK PRO as a 4-channel stereo splitter	14
6.3 Application as a matching amplifier	15
7. SPECIFICATIONS	16
8. WARRANTY	17

1. INTRODUCTION

With the BEHRINGER ULTRALINK PRO you have purchased an ultra-flexible "problem solver" in signal distribution applications, designed to meet highest requirements: professional recording, broadcast and television studios, CD and digital production facilities, etc. Much like an all-in-one tool, it provides virtually unlimited configurations. Be it the distribution of a stereo signal to several outputs (splitter); the combination of separate signals to one stereo output (mixer), or the specific level adaption of individual signals (buffer amplifier): the ULTRALINK PRO can perform all of these functions easily - and simultaneously.

Future-oriented BEHRINGER technology

Our ULTRALINK range of devices has been a hit ever since we introduced our first model several years ago. This splitter/mixer is based on many years of experience and findings in mixing technology and is used throughout the world in renowned studios, sound reinforcement systems as well as in broadcast and television studios.

It was a real challenge to improve the well-known ULTRALINK even further, and we are proud of our success. Compared to its predecessor models, the ULTRALINK PRO not only has additional features, but also comes with dramatically improved functionality. For example, it now has input and output level meters and balanced in- and outputs.

The architecture of the ULTRALINK PRO

Basically the unit consists of six mono channels, which can be used either as a splitter or as a mixer. For instance, a stereo program source can be inserted via the main input to be subsequently routed to any of the mono channels that are set to SPLIT mode. Using the individual BALANCE/PAN control, you can - for each channel - determine the ratio between the left and right main input signals that are routed to the corresponding output of the channels. Thus, the stereo input signal coming from the main input section can be distributed selectively among the six mono output channels.

In MIX mode, the input signals from the respective channel(s) can be mixed at the stereo main output, with the individual BALANCE/PAN control determining the signal ratio between the left and right main outputs (pan function). It is of particular advantage that, in MIX mode, the stereo input signal from the main input section is alternatively routed to the main outputs. By using this feature a total of up to 8 single signals can be combined.

In MIX mode, the mono input signals are simultaneously applied to the respective mono outputs, which permits each channel to be used as an individual matching amplifier. The LEVEL controls in the corresponding channels enable the user to adapt the levels at will, with a maximum gain of +15 dB. Levels used in home-recording can therefore be converted into studio levels (+4 dBu), and vice versa.

Typical applications

The ULTRALINK PRO MX882 is one of the most flexible systems of its type. The following applications can be realized:

2 IN/8 OUT splitter, 8 IN/2 OUT mixer, 6 IN/6 OUT matching amplifier or any other combination.

- ▲ Keyboard submixer
- ▲ Distribution amplifier for PA systems, discotheques, theatres, churches, hotels, communication systems, etc.
- ▲ Add-on module for mixer channels
- ▲ Add-on module for effect and monitor paths
- ▲ Level translator from -10 dBV to +4 dBu etc.

By combining several ULTRALINK PROs you can set up, for instance, a 24-channel mixer or splitter.

 **The following operational manual will introduce you to the BEHRINGER ULTRALINK PRO and its various functions. After reading the manual carefully, make sure it is always on hand for future reference.**

2. THE DESIGN CONCEPT

2.1 High quality components and design

The philosophy behind BEHRINGER products guarantees a no-compromise circuit design and employs the best choice of components. The operational amplifiers NJM4580 which are used in the ULTRALINK PRO, are exceptional. They boast extreme linearity and very low distortion characteristics. To complement this design the choice of components includes high tolerance resistors and capacitors, detent potentiometers and several other stringently selected elements.

For the first time, the ULTRALINK PRO MX882 uses SMD technology (Surface Mounted Device). These sub-miniature components known from aerospace technology allow for an extreme packing density and improved reliability. Additionally, the unit is manufactured in compliance with a ISO9000 certified management system.

2.2 Inputs and outputs

2.2.1 Balanced inputs and outputs

As standard, the BEHRINGER ULTRALINK PRO is installed with electronically servo-balanced inputs and outputs. The new circuit design features automatic hum and noise reduction for balanced signals and thus allows for trouble-free operation, even at high operating levels. Externally induced mains hum etc. will be effectively suppressed. The automatic servo-function recognizes the presence of unbalanced connectors and adjusts the nominal level internally to avoid level differences between the input and output signals (correction 6 dB).

3. INSTALLATION

Your BEHRINGER ULTRALINK PRO was carefully packed in the factory and the packaging was designed to protect the unit from rough handling. Nevertheless, we recommend that you carefully examine the packaging and its contents for any signs of physical damage, which may have occurred in transit.

 **If the unit is damaged, please do not return it to us, but notify your dealer and the shipping company immediately, otherwise claims for damage or replacement may not be granted. Shipping claims must be made by the consignee.**

3.1 Rack mounting

The BEHRINGER ULTRALINK PRO fits into one standard 19" rack unit of space (1 3/4"). Please allow at least an additional 4" depth for the connectors on the back panel. Be sure that there is enough air space around the unit for cooling and please do not place the ULTRALINK PRO on high temperature devices such as power amplifiers etc. to avoid overheating.

3.2 Mains voltage

Before you connect your ULTRALINK PRO to the mains, please make sure that your local voltage matches the voltage required by the unit! The fuse holder on the female mains connector has 3 triangular markers, with two of these triangles opposing each other. Your ULTRALINK PRO is set to the operating voltage printed next to these markers, and can be set to another voltage by turning the fuse holder by 180°. **CAUTION: this instruction does not apply to export models exclusively designed, e.g. for 115 V operation!**

3.3 Audio connections

The audio inputs and outputs on the BEHRINGER ULTRALINK PRO are fully balanced. If possible, connect the unit to other devices in a balanced configuration to allow for maximum interference immunity.

 Please ensure that only qualified persons install and operate the ULTRALINK PRO. During installation and operation the user must have sufficient electrical contact to earth. Electrostatic charges might affect the operation of the ULTRALINK PRO!

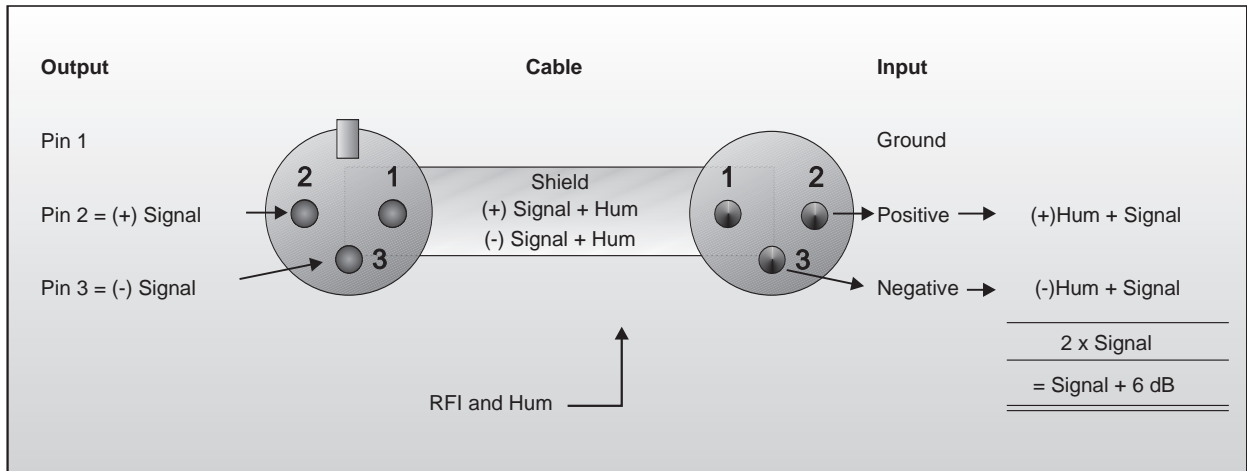

Fig. 3.1: Compensation of interference with balanced connections

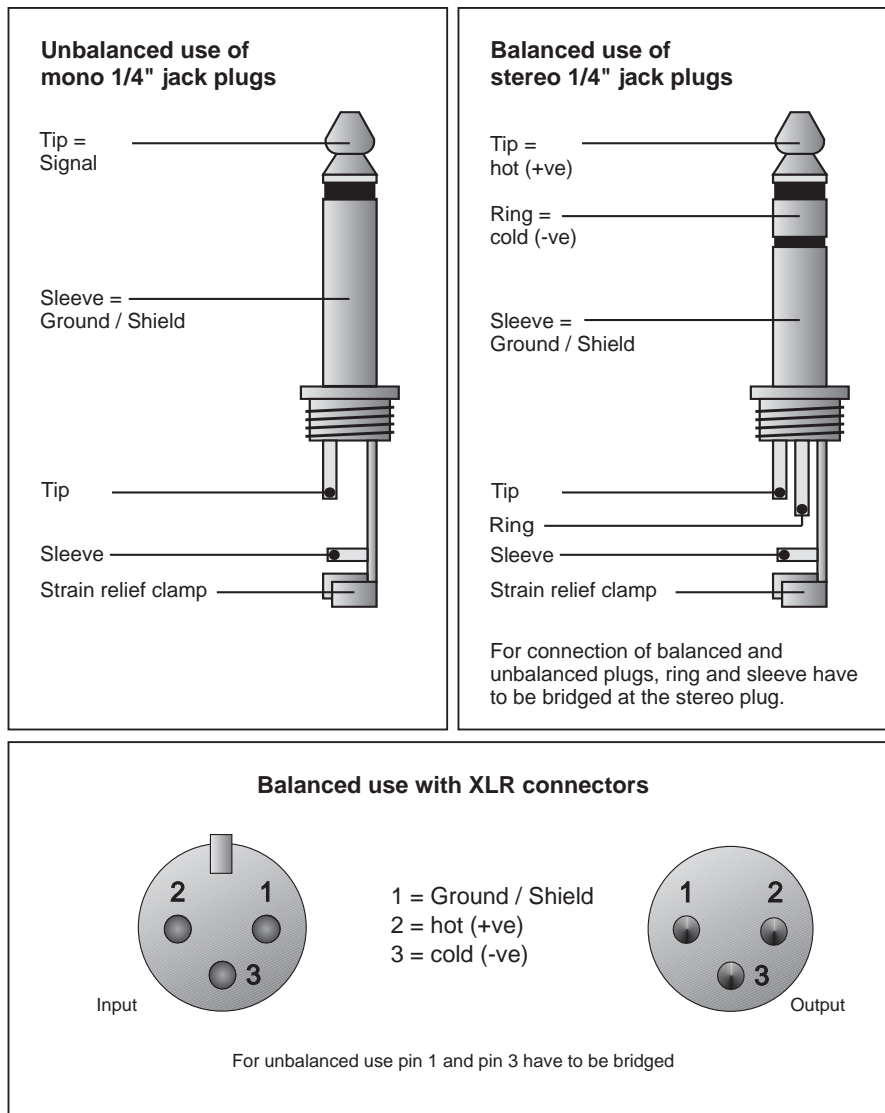

Fig. 3.2: Different plug types



4. CONTROLS

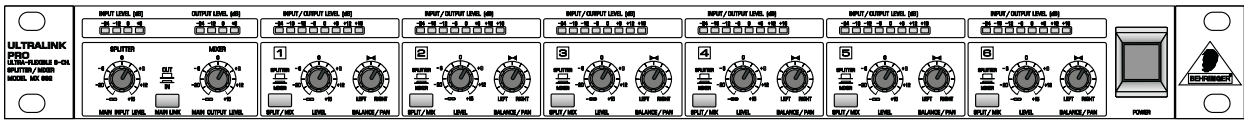

Fig. 4.1: ULTRALINK PRO front panel

The BEHRINGER ULTRALINK PRO has six identical channels. Each channel is equipped with two rotary controls, one button and eight LEDs. Moreover there is a main section with two rotary controls, one button and eight LEDs.

4.1 The front panel control elements

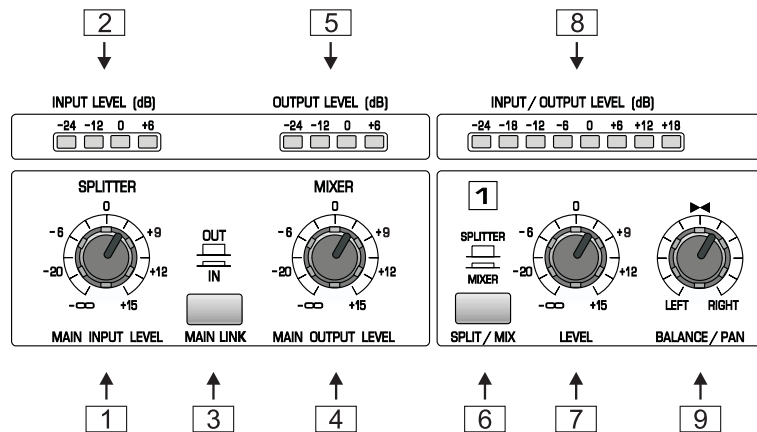

Fig. 4.2: Control elements on the front panel

- 1 The **MAIN INPUT LEVEL** control sets the main input gain, before the signal reaches the input bus. In SPLIT mode, the **MAIN INPUT LEVEL** control determines the common output level for all mono outputs.
- 2 The 4-digit **INPUT LEVEL** meter informs you about the input level of the main input within a range from -24 to +6 dB.
- 3 By depressing the **MAIN LINK** switch you can route the **MAIN INPUT** signal to the **MAIN OUT**. This way it is possible to route a maximum of eight input channels to the main mix.
- 4 The **MAIN OUTPUT LEVEL** control adjusts the output level applied to the main outputs. The levels present at the six mono outputs are not affected. Summing the signal levels of several mono channels can overload the main output stage. The **MAIN OUTPUT LEVEL** control is therefore used to adjust the overall output level.
- 5 The 4-digit **OUTPUT LEVEL** meter informs you about the output level of the main input within a range from -24 to +6 dB.
- 6 This **SPLIT/MIX** switch sets the respective channel to SPLITTER or MIXER mode.
- 7 The **LEVEL** control determines the signal level of the individual channels. In SPLIT mode, the **LEVEL** control sets the output level of the mono channels. In MIX mode, however, it controls the amount of the mono channel's input signal feeding into the main output section; at the same time, the level of the mono channel can be determined, which - owing to the maximum gain of +15 dB - allows for converting, e.g., home recording levels (-10 dBV) into studio levels (+4 dBu).
- 8 The 8-digit **OUTPUT LEVEL** meter informs you about the output level of each channel within a range from -24 to +18 dB.

- 9 With the *BALANCE/PAN* control you can set the balance between the left and right main signals. In *SPLIT* mode, the main input signal is routed to the mono output, with the *BALANCE* control determining the balance between the left and right main signal portions. In *MIX* mode, the mono inputs are mixed and routed via the *LEVEL* control to the main outputs, with the *PAN* controls determining the allocation of the mono inputs to the left and right main outputs.

4.2 The rear panel elements

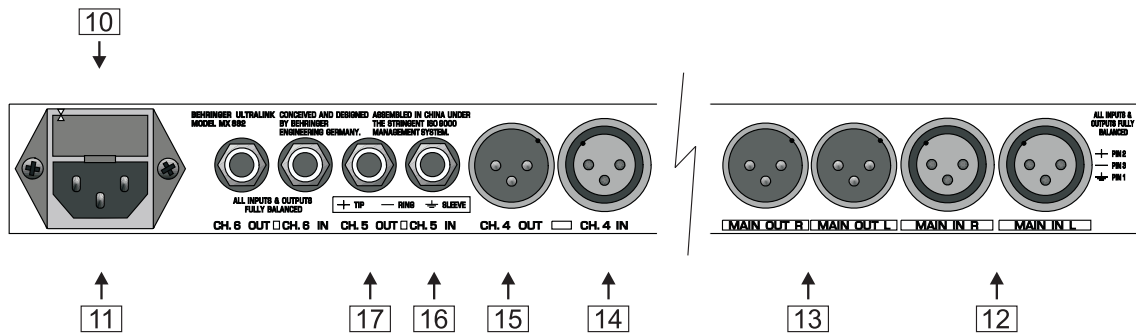

Fig. 4.3: Rear panel elements

- 10 **FUSE HOLDER / VOLTAGE SELECTOR.** Please make sure that your local voltage matches the voltage indicated on the unit, before you attempt to connect and operate the ULTRALINK PRO. Blown fuses may only be replaced by fuses of the same type and rating.
- 11 **MAINS CONNECTION.** Use the enclosed power cord to connect the unit to the mains. Please also note the instructions given in the "INSTALLATION" chapter.
- 12 **MAIN INPUTS.** These are the main audio inputs of your ULTRALINK PRO, available as balanced XLR connectors. They may feed the mono outputs of all channels which are operated in *SPLIT* mode.
- 13 **MAIN OUTPUTS.** These are the main outputs, available as balanced XLR connectors. They may be fed either by the left and right main inputs or by any of the six mono inputs (or a combination of both).
- 14 **MONO INPUTS (channel 1 to 4).** These are the mono inputs. Connection takes place via balanced XLR connectors.
- 15 **MONO OUTPUTS (channel 1 to 4).** These are the mono outputs, available as balanced XLR connectors.
- 16 **MONO INPUTS (channel 5 to 6).** These are the mono inputs. Connection takes place via balanced phone jacks.
- 17 **MONO OUTPUTS (channel 5 to 6).** These are the mono outputs, available as balanced phone jacks.

5. BLOCK DIAGRAM

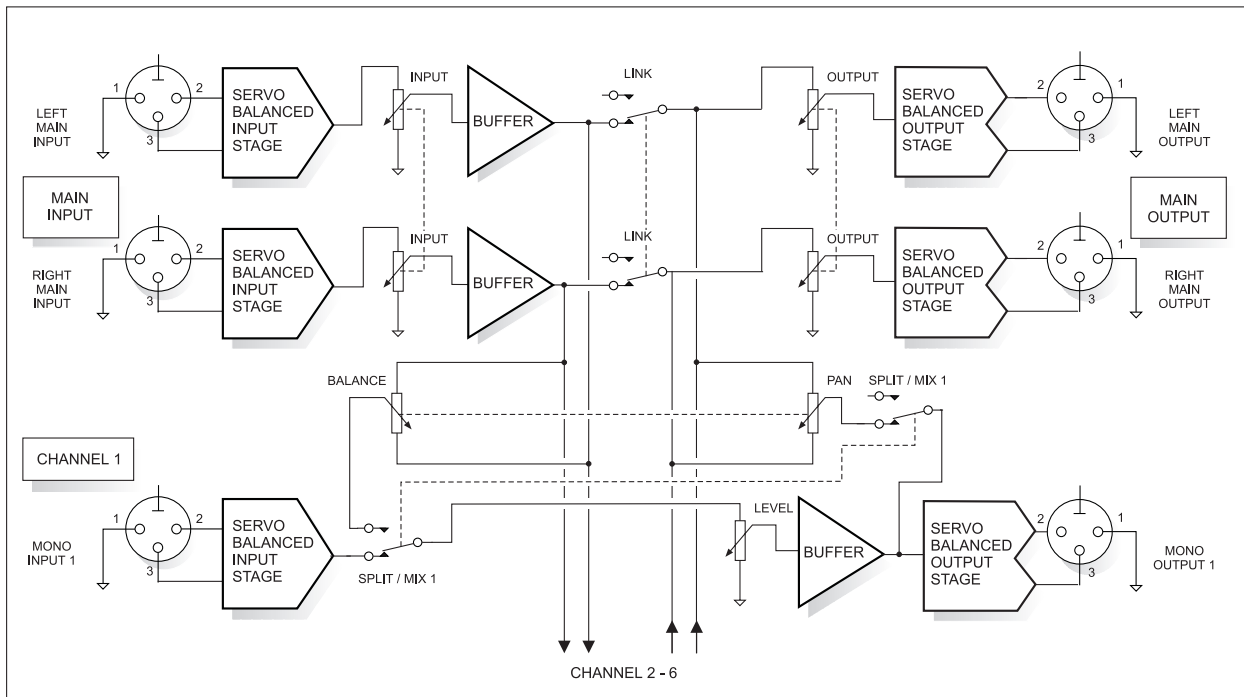

Fig. 5.1: Block diagram of the BEHRINGER ULTRALINK PRO MX882

MAIN Section

Both main inputs interface via the MAIN INPUT LEVEL control with the input bus as well as with the main outputs. The MAIN OUTPUT LEVEL control determines the output level of the signals which are summed by the second bus (i.e., the output bus) and are subsequently routed to the main outputs.

SPLIT Mode

In SPLIT mode, the main input signal is sent via the BALANCE control to the output buffer amplifiers of the mono channels, with the LEVEL control determining the output level of the respective channel. The maximum gain is +15 dB.

MIX Mode

In MIX mode, the input signals of the mono channels are "collected" via the LEVEL and PAN controls and are routed to the output bus. In this mode, the LEVEL control determines the amount of each channel at the output bus, while the PAN control is responsible for the allocation of the input signal to the left and right main outputs.

Additionally, the input signal is routed to the respective mono outputs, i.e., the circuit acts as a matching amplifier. The LEVEL control allows for level compensation of up to +15 dB.

6. APPLICATIONS

6.1 Application as a mixer

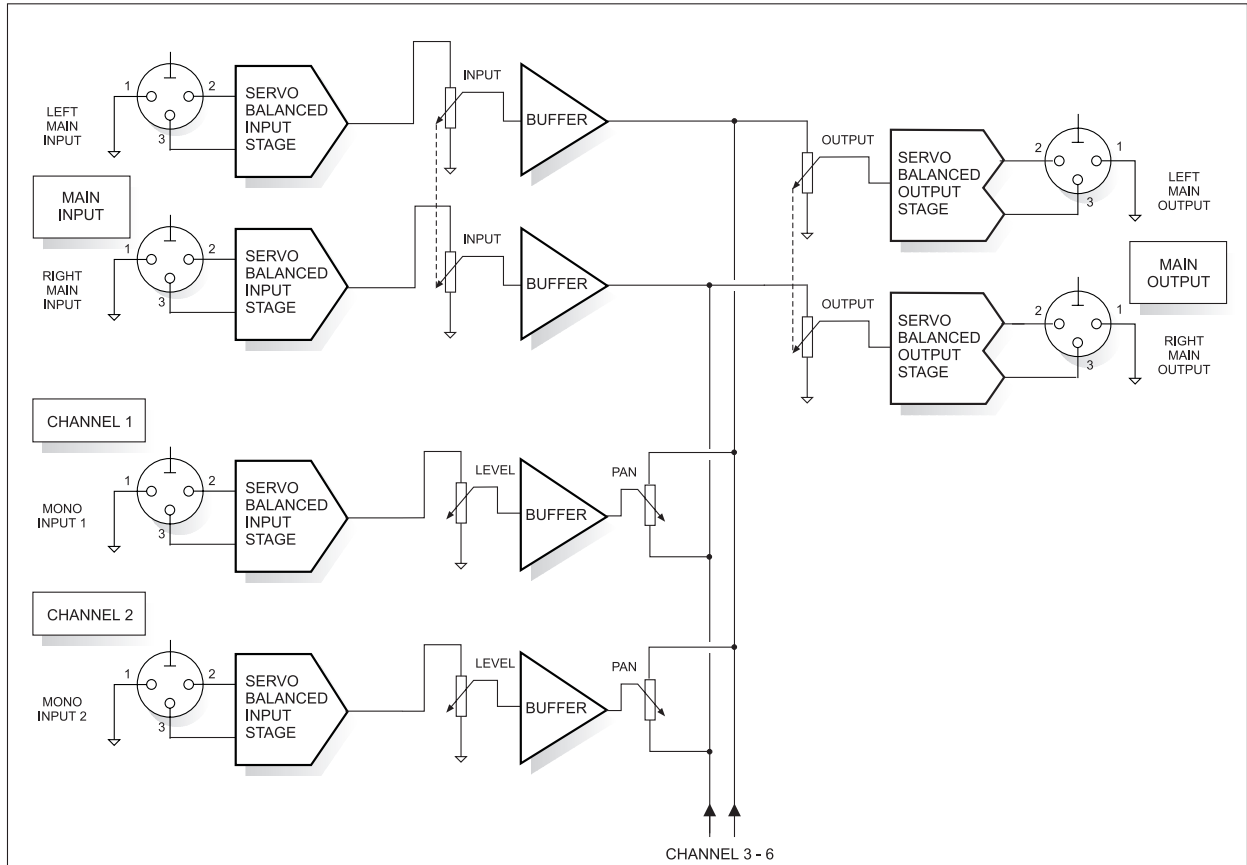

Fig. 6.1: Block diagram of the MIXER function

When the mono channels are operated in MIX mode, a maximum of 8 (6+2) mono input signals can be summed and routed to the main outputs. In this mode, the individual signal sources are connected to the mono inputs on the BEHRINGER ULTRALINK PRO. Each channel has a LEVEL knob to control the amount of its signal relative to others in the main section. Via the corresponding PAN control, each mono input signal can be routed either to the left or right main output. Of course, any intermediate pan settings can be achieved as well. The MAIN OUTPUT LEVEL control determines the overall level of the main output signal.

Since the two main inputs are alternatively routeable to the main outputs, two additional input signals can be added using the main inputs. For this you have to depress the MAIN LINK switch. However, as these inputs do not feature a PAN control, the left main input will always be routed to the left main output; similarly, the right main input can only be sent to the right main output. A total of 8 mono channels can thus be routed to two main outputs.

6.2 Application as a splitter

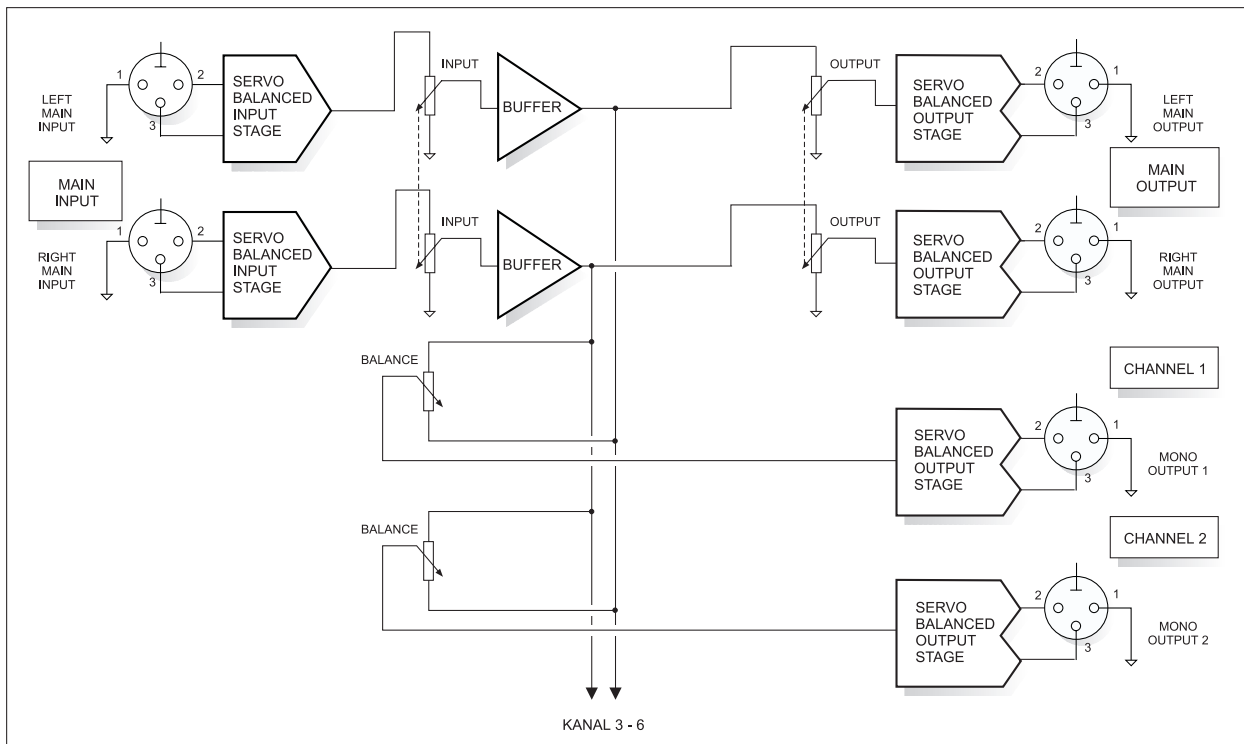

Fig. 6.2: Block diagram of the SPLITTER function

A splitter is a distribution amplifier which allows for splitting a specific input signal to several outputs. This function is of use, e.g., in a large-scale sound reinforcement system where the mixer's output signal needs to be allocated to several power amplifiers. Another field of application is in tape duplication systems, where one master tape machine is to be interfaced with several tape duplication recorders.

In this mode, the output signal from the mixer is applied to the main inputs of the BEHRINGER ULTRALINK PRO. If the SPLIT/MIX switches are set to "SPLIT", the mono outputs of the respective channels provide either the left or the right main signal. Depending on the setting of the BALANCE control, any balance between left and right main signal can be adjusted.

At the same time, the main input signal is also sent to the left or right main output, so that here two additional splitter outputs are available. Please note that these outputs do not feature a balance routing function. The left main input is routed exclusively to the left main output; similarly, the right main input feeds the right main output only.

6.2.1 The ULTRALINK PRO as a 4-channel stereo splitter

For this special application, the splitter function configures the unit as a 4-channel stereo splitter. Here, the stereo signal source is connected to the two main inputs. If all mono channels are operated in SPLIT mode, the BALANCE controls of channels 1, 3, and 5 are set to "LEFT", and the BALANCE controls of channels 2, 4, and 6 to "RIGHT": thus, the corresponding stereo output pairs are routed through channels 1+2, 3+4, and 5+6. This kind of application is particularly useful for tape duplication systems.

6.3 Application as a matching amplifier

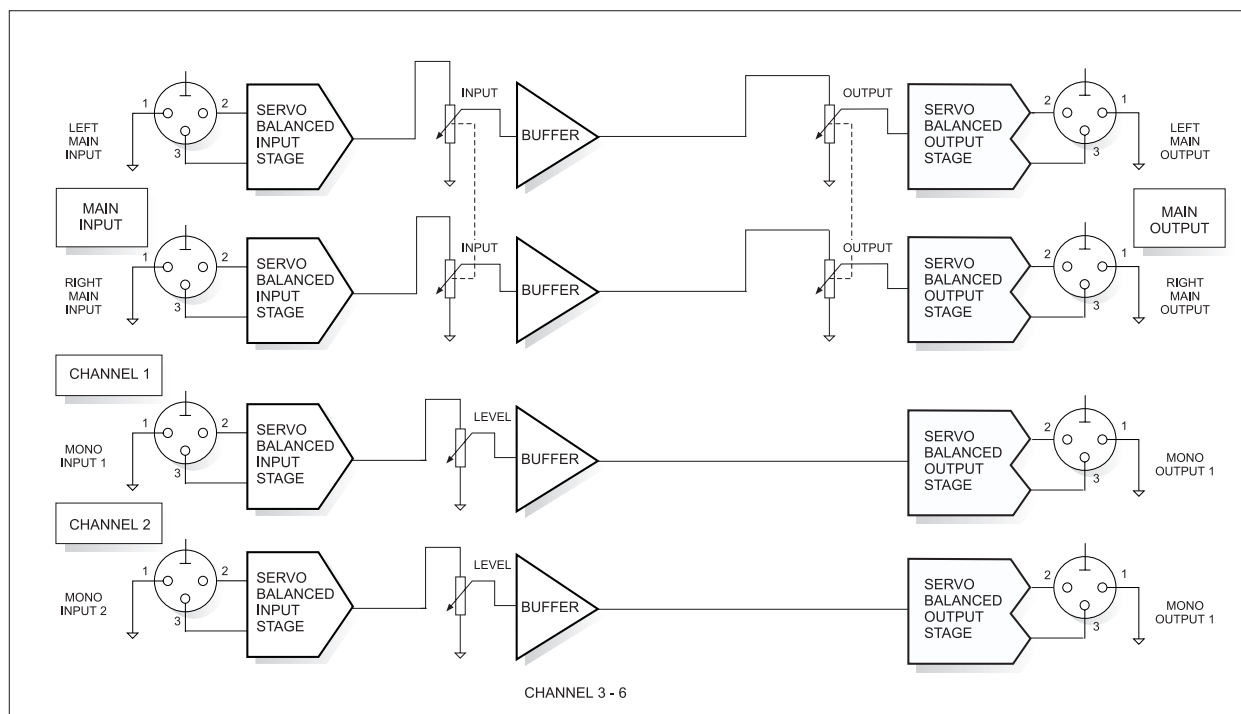

Fig. 6.3: Block diagram of the MATCHING AMPLIFIER function

The BEHRINGER ULTRALINK PRO can also be used as a multiple matching amplifier. The task of a matching amplifier is to convert the level of a signal source into another level. For instance, a cassette recorder with home recording level (-10 dBV) can be raised to studio level (+4 dBu). Of course, this process can also be reversed (level attenuation).

In this application, the ULTRALINK PRO is operated in MIX mode. The output of the signal source is connected to the mono input of the ULTRALINK PRO. The corresponding mono output provides the resulting output signal which can be raised or lowered in level. Each of the six mono channels is equipped with a LEVEL control. The control range is from $-\infty$ (full attenuation) to a maximum gain of +15 dB.

7. SPECIFICATIONS

AUDIO INPUTS

Connectors	XLR and 1/4" jack
Type	RF filtered, servo-balanced input
Impedance	50 kOhms balanced, 25 kOhms unbalanced
Nominal operating level	-10 dBV to +4 dBu
Max. input level	+21 dBu balanced and unbalanced
CMRR	Typ. 40 dB, > 55 dB @ 1 kHz

AUDIO OUTPUTS

Connectors	XLR and 1/4" jack
Type	Electronically servo-balanced output stage
Impedance	60 Ohms balanced, 30 Ohms unbalanced
Max. output level	+22 dBu balanced and unbalanced

SYSTEM SPECIFICATIONS

Frequency response	5 Hz to 200 kHz, +/- 3 dB
S/N ratio	>95 dBu, unweighted, 22 Hz to 22 kHz
THD	0.002 % typ. @ +4 dBu, 1kHz, gain 1

FUNCTION CONTROLS

Main input level	variable
Main output level	variable
Level	variable for each channel
Balance/pan	placing in the stereo field

FUNCTION SWITCHES

Main Link	links the main input signal to the main output
Split/mix	changeover from split to mix mode for each channel

INDICATORS

Input level (main)	4-digit LED display: -24/-12/0/+6 dB
Output level (main)	4-digit LED display: -24/-12/0/+6 dB
Input/output level	8-digit LED display: -24/-18/-12/-6/0/+6/+12/+18 dB

POWER SUPPLY

Mains Voltages	USA/Canada ~ 120 V AC, 60 Hz
	U.K./Australia ~ 240 V AC, 50 Hz
	Europe ~ 230 V AC, 50 Hz
	General Export Model ~ 100-120 V AC, ~ 200-240 V AC, 50-60 Hz
Power Consumption	10 Watts
Fuse	100-120 V AC: 630 mA (slow-blow)
	200-240 V AC: 315 mA (slow-blow)
Mains Connection	Standard IEC receptacle

PHYSICAL

Dimension	1 3/4" (44.5 mm) * 19" (482.6 mm) * 8.5" (217 mm)
Net Weight	approx. 3.0 kg
Shipping Weight	approx. 3.8 kg

BEHRINGER is constantly striving to maintain the highest professional standards. As a result of these efforts, modifications may be made from time to time to existing products without prior notice. Specifications and appearance may differ from those listed or shown.

8. WARRANTY

§ 1 WARRANTY CARD

To be protected by this warranty, the buyer must complete and return the enclosed warranty card (signed/stamped by retail dealer) within 14 days of the date of purchase to BEHRINGER INTERNATIONAL (address see § 3). Failure to return the card in due time (date as per postmark) will void any extended warranty claims.

§ 2 WARRANTY

1. BEHRINGER INTERNATIONAL warrants the mechanical and electronic components of this product to be free of defects in material and workmanship for a period of one (1) year from the original date of purchase, in accordance with the warranty regulations described below. If any defects occur within the specified warranty period that are not caused by normal wear or inappropriate use, BEHRINGER INTERNATIONAL shall, at its sole discretion, either repair or replace the product.

2. If the warranty claim proves to be justified, the product will be returned freight prepaid by BEHRINGER INTERNATIONAL within Germany. Outside of Germany, the product will be returned at the buyer's expense.

3. Warranty claims other than those indicated above are expressly excluded.

§ 3 RETURN AUTHORIZATION NUMBER

1. To obtain warranty service, the buyer must call BEHRINGER INTERNATIONAL during normal business hours BEFORE returning the product (Tel.: +49 (0) 21 54 / 92 06 66). All inquiries must be accompanied by a description of the problem. BEHRINGER INTERNATIONAL will then issue a return authorization number.

2. The product must be returned in its original shipping carton, together with the return authorization number, to the following address:

**BEHRINGER INTERNATIONAL GmbH
Service Department**

Hanns-Martin-Schleyer-Str. 36-38

D - 47877 Willich-Münchheide

3. Shipments without freight prepaid will not be accepted.

§ 4 WARRANTY REGULATIONS

1. Warranty services will be furnished only if the product is accompanied by an original retail dealer's invoice. Any product deemed eligible for repair or replacement by BEHRINGER INTERNATIONAL under the terms of this warranty will be repaired or replaced within 30 days of receipt of the product at BEHRINGER INTERNATIONAL.

2. If the product needs to be modified or adapted in order to comply with applicable technical or safety standards on a national or local level, in any country which is not the country for which the product was originally developed and manufactured, this modification/adaptation shall not be considered a defect in materials or workman-

ship. The warranty does not cover any such modification/adaptation, irrespective of whether it was carried out properly or not. Under the terms of this warranty, BEHRINGER INTERNATIONAL shall not be held responsible for any cost resulting from such a modification/adaptation.

3. Free inspections, maintenance/repair work and replacement of parts are expressly excluded from this warranty, in particular if caused by inappropriate use. Likewise, the warranty does not cover defects of expendable parts caused by normal wear of the product. Expendable parts are typically faders, potentiometers, switches and similar components.

4. Damages/defects caused by the following conditions are not covered by this warranty:

▲ misuse, neglect or failure to operate the unit in compliance with the instructions given in the user or service manuals.

▲ connection or operation of the unit in any way that does not comply with the technical or safety regulations applicable in the country where the product is used.

▲ damages/defects that are caused by force majeure or by any other condition beyond the control of BEHRINGER INTERNATIONAL.

5. Any repair carried out by unauthorized personnel will void the warranty.

6. Products which do not meet the terms of this warranty will be repaired exclusively at the buyer's expense. BEHRINGER INTERNATIONAL will inform the buyer of any such circumstance. If the buyer fails to submit a written repair order within 4 weeks after notification, BEHRINGER INTERNATIONAL will return the unit C.O.D. with a separate invoice for freight and packing. Such cost will also be invoiced separately when the buyer has sent in a written repair order.

§ 5 WARRANTY TRANSFERABILITY

This warranty is extended exclusively to the original buyer (customer of retail dealer) and is not transferable to anyone who may subsequently purchase this product. No other person (retail dealer, etc.) shall be entitled to give any warranty promise on behalf of BEHRINGER INTERNATIONAL.

§ 6 CLAIM FOR DAMAGES

Failure of BEHRINGER INTERNATIONAL to provide proper warranty service shall not entitle the buyer to claim (consequential) damages. In no event shall the liability of BEHRINGER INTERNATIONAL exceed the invoiced value of the product.

§ 7 OTHER WARRANTY RIGHTS

This warranty does not exclude or limit the buyer's statutory rights provided by national law, in particular, any such rights against the seller that arise from a legally effective purchase contract.

The information contained in this manual is subject to change without notice. No part of this manual may be reproduced or transmitted in any form or by any means, electronic or mechanical, including photocopying and recording of any kind, for any purpose, without the express written permission of BEHRINGER GmbH.

BEHRINGER is a registered trademarks. ALL RIGHTS RESERVED © 1999 BEHRINGER.
BEHRINGER INTERNATIONAL GmbH, Hanns-Martin-Schleyer-Str. 36-38, D-47877 Willich-Münchheide II
Tel. +49 (0) 21 54 / 92 06-0, Fax +49 (0) 21 54 / 92 06-30

