

CX-3

COMBO ORGAN

Owner's Manual

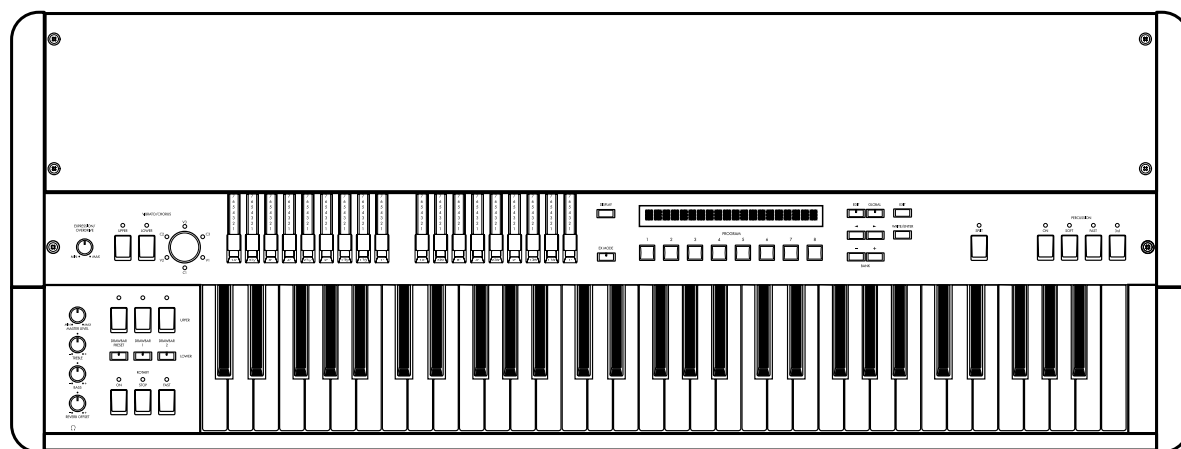

KORG

INSTRUCTIONS PERTAINING TO A RISK OF FIRE, ELECTRIC SHOCK, OR INJURY TO PERSONS

IMPORTANT SAFETY INSTRUCTIONS

WARNING—When using electric products, basic precautions should always be followed, including the following:

- 1) Read all the instructions before using the product.
- 2) Do not use this product near water—for example, near a bathtub, washbowl, kitchen sink, in a wet basement, or near a swimming pool, or the like.
- 3) This product should be used only with a cart or stand that is recommended by the manufacturer.
- 4) This product, either alone or in combination with an amplifier and headphones or speakers, may be capable of producing sound levels that could cause permanent hearing loss. Do not operate for a long period of time at a high volume level or at a level that is uncomfortable. If you experience any hearing loss or ringing in the ears, you should consult an audiologist.
- 5) The product should be located so that its location or position does not interfere with its proper ventilation.
- 6) The product should be located away from heat sources such as radiators, heat registers, or other products that produce heat.
- 7) The product should be connected to a power supply only of the type described in the operating instructions or as marked on the product.
- 8) The power-supply cord of the product should be unplugged from the outlet when left unused for a long period of time.
- 9) Care should be taken so that objects do not fall and liquids are not spilled into the enclosure through openings.
- 10) The product should be serviced by qualified service personnel when:
 - a) The power-supply cord or the plug has been damaged; or
 - b) Objects have fallen, or liquid has been spilled onto the product; or
 - c) The product has been exposed to rain; or
 - d) The product does not appear to operate normally or exhibits a marked change in performance; or
 - e) The product has been dropped, or the enclosure damaged.
- 11) Do not attempt to service the product beyond that described in the user-maintenance instructions. All other servicing should be referred to qualified service personnel.

SAVE THESE INSTRUCTIONS

WARNING:

TO REDUCE THE RISK OF FIRE OR ELECTRIC SHOCK DO NOT EXPOSE THIS PRODUCT TO RAIN OR MOISTURE.

	CAUTION RISK OF ELECTRIC SHOCK DO NOT OPEN	
AVERTISSEMENT: RISQUE DE CHOC ÉLECTRIQUE—NE PAS OUVRIR.		
注意 感電の恐れあり、キャビネットをあげるな		
CAUTION: TO REDUCE THE RISK OF ELECTRIC SHOCK, DO NOT REMOVE COVER (OR BACK). NO USER-SERVICEABLE PARTS INSIDE. REFER SERVICING TO QUALIFIED SERVICE PERSONNEL.		



The lightning flash with arrowhead symbol within an equilateral triangle, is intended to alert the user to the presence of uninsulated “dangerous voltage” within the product’s enclosure that may be of sufficient magnitude to constitute a risk of electric shock to persons.



The exclamation point within an equilateral triangle is intended to alert the user to the presence of important operating and maintenance (servicing) instructions in the literature accompanying the product.

GROUNDING INSTRUCTIONS

This product must be grounded. If it should malfunction or breakdown, grounding provides a path of least resistance for electric current to reduce the risk of electric shock. This product is equipped with a cord having an equipment-grounding conductor and a grounding plug. The plug must be plugged into an appropriate outlet that is properly installed and grounded in accordance with all local codes and ordinances.

DANGER—Improper connection of the equipment-grounding conductor can result in a risk of electric shock. Check with a qualified electrician or serviceman if you are in doubt as to whether the product is properly grounded. Do not modify the plug provided with the product—if it will not fit the outlet, have a proper outlet installed by a qualified electrician.

THE FCC REGULATION WARNING (for U.S.A.)

This equipment has been tested and found to comply with the limits for a Class B digital device, pursuant to Part 15 of the FCC Rules. These limits are designed to provide reasonable protection against harmful interference in a residential installation. This equipment generates, uses, and can radiate radio frequency energy and, if not installed and used in accordance with the instructions, may cause harmful interference to radio communications. However, there is no guarantee that interference will not occur in a particular installation. If this equipment does cause harmful interference to radio or television reception, which can be determined by turning the equipment off and on, the user is encouraged to try to correct the interference by one or more of the following measures:

- Reorient or relocate the receiving antenna.
 - Increase the separation between the equipment and receiver.
 - Connect the equipment into an outlet on a circuit different from that to which the receiver is connected.
 - Consult the dealer or an experienced radio/TV technician for help.
- Unauthorized changes or modification to this system can void the user’s authority to operate this equipment.

CE mark for European Harmonized Standards

CE mark which is attached to our company’s products of AC mains operated apparatus until December 31, 1996 means it conforms to EMC Directive (89/336/EEC) and CE mark Directive (93/68/EEC). And, CE mark which is attached after January 1, 1997 means it conforms to EMC Directive (89/336/EEC), CE mark Directive (93/68/EEC) and Low Voltage Directive (73/23/EEC). Also, CE mark which is attached to our company’s products of Battery operated apparatus means it conforms to EMC Directive (89/336/EEC) and CE mark Directive (93/68/EEC).

IMPORTANT NOTICE FOR THE UNITED KINGDOM

WARNING—THIS APPARATUS MUST BE EARTHED

As the colours of the wires in the mains lead of this apparatus may not correspond with the coloured markings identifying the terminals in your plug, proceed as follows:

- the wire which is coloured green and yellow must be connected to the terminal in the plug which is marked with the letter E or by the earth symbol \oplus , or coloured green or green and yellow.
- the wire which is coloured blue must be connected to the terminal which is marked with the letter N or coloured black.
- the wire which is coloured brown must be connected to the terminal which is marked with the letter L or coloured red.

Thank you for purchasing the Korg **CX-3** combo organ. To ensure trouble-free enjoyment, please read this manual carefully and use the instrument as directed.

About this owner's manual

How this manual is organized, and how to use it

First read this manual carefully for important notes and to learn basic operation.

“**Introduction**” explains the various controls and their functions, and how to make connections.

“**Basic operation**” explains how to use the CX-3 (selecting programs, modifying the sound, making effect settings, simple editing, and demo playback etc.).

“Parameters” explains the function, settings, and notes on the parameters of each mode. Refer to this section when an unfamiliar parameter is displayed, or when you wish to learn more about a function.

“**Appendices**” explains how to make settings when connecting the CX-3 to a MIDI sequencer or a computer, explains how to perform data dumps, provides lists of the sounds built into the CX-3, and gives the specifications.

Printing conventions in this manual

Keys and knobs ... []

Keys and knobs etc. on the front panel of the CX-3 are enclosed in square brackets [].

Parameters

Parameters that appear in the display are enclosed in quotation marks “ ”.

p. ■

This indicates a page for reference.

symbol

This symbol indicates a cautionary note.

symbol

This symbol indicates a useful hint or application.

Display screen

The parameter values and program names etc. appearing in the screens printed in this manual are only examples; they will not necessarily match the values or names that appear in the screen of your CX-3.

MIDI-related conventions

CC# is an abbreviation for Control Change Number.

In the context of a MIDI message, all numbers in square brackets [] are in hexadecimal notation.

Contents

Introduction	1	5. Listening to the demo songs	13
1. About the CX-3	1	6. Editing a program	14
Main features	1	Editing the drawbar parameters	14
The modes of the CX-3	1	Copying drawbar parameters	14
2. Controls and their functions	2	Parameters unique to a combo organ	15
Front panel	2	Other editing	15
Rear panel	5	Writing a program	15
Connections	6	Writing global settings	16
1. Power cable connections	6	Copying a program	16
2. OUTPUT jack connections	6	Returning a program to the factory settings	16
3. Pedal connections	6		
4. MIDI connections	6		
Basic operation	7	Parameters	17
1. The display screen	7	1. Normal Edit mode / EX Edit mode	17
Switching the display	7	2. Global mode	22
In Normal mode	7		
In EX mode	7	Appendices	27
Drawbar levels and icons	7	1. How the drawbars work	27
Shortcut	7	2. MIDI applications	27
2. About programs	8	About MIDI	27
How a program is organized	8	Connecting an external MIDI sequencer or	
Selecting a program	8	computer	27
3. Playing the CX-3	8	MIDI data dump	28
Play using the drawbars	8	Transmission	28
Normal mode	8	Reception	29
EX mode	9	Receiving a data dump	29
Play using the drawbar parameter settings of a		MIDI messages that the CX-3 transmits and	
program	10	receives	29
Normal mode	10	3. Voice name list	31
EX mode	10	Normal mode programs	31
Dividing the keyboard into left and right	11	EX mode programs	31
4. Applying effects to your performance	11	Demo song names	31
Percussion	11	4. Troubleshooting	32
Normal mode	11	5. Specifications and options	33
EX mode	12	6. MIDI implementation chart	34
Key settings of the PERCUSSION section	12		
Vibrato and chorus	12	Index	35
Rotary speaker	12		
Key settings of the ROTARY section	13		
Other effects	13		
Overdrive	13		
Reverb	13		

Introduction

1. About the CX-3

Main features

The CX-3 contains a newly developed **tone wheel organ modeling tone generator** that reproduces the distinctive sound of a tone wheel organ.

REMS technology is used to create spatial effects such as rotary, chorus/vibrato, and reverb, faithfully simulating the effects of a combo organ. It creates the modulated sounds produced by the turning rotor and horn, the natural overdrive, and chorus/vibrato to produce an authentic sense of presence. The CX-3 is all you need to enjoy real organ sound.

By operating the two sets of **drawbars** on the front panel, you can modify the sound in realtime while you play. In **Normal mode**, the sound is created using one set of these drawbars. In **EX mode**, the sound is created using both sets of drawbars. In EX mode, you can use the drawbars to control percussion, creating new sounds that could not be produced before.

A conventional keyboard will not sound until you depress the key all the way; however the CX-3 will sound when a key is even slightly depressed. This allows more rapid response, and ensures precise glissandi and trills.

The CX-3 lets you produce **the percussive** “clunk” sound that is characteristic of tone wheel organs. You can also make settings so that a **key click** is heard when you press and release a key, creating the sense of attack that is distinctive on these organs.

128 programs are built-in (Normal mode: 64, EX mode: 64), allowing you to enjoy a variety of organ sounds.

The CX-3 has two tone generators, **the Upper tone generator** and **the Lower tone generator**. In **Normal mode**, you can use both the upper and the lower tone generator. In **EX mode**, you can use only the Upper tone generator.

In **Normal mode**, you can use **the Split function** to divide the keyboard into two areas, and play different sounds as though you were using two keyboards.

If you do not use Split, the keyboard will use **the Upper tone generator**. If you use Split, the right side of the keyboard will use **the Upper tone generator**, and the left side will use **the Lower tone generator**.

The Upper and Lower tone generators can be assigned separate MIDI channels, so that either tone generator can be used from an external MIDI keyboard connected to the MIDI connector.

To create its sound, the CX-3 uses the Drawbar 1 and Drawbar 2 sets on its front panel, and the drawbars specified by each program. Drawbar settings can also be set via MIDI.

By using the keys of the DRAWBAR SELECT section you can use the drawbar settings that you wish. (Refer to the diagram.)

What is REMS?

REMS (Resonant structure and Electronic circuit Modeling System) is KORG's proprietary sound modeling technology which precisely reproduces the complex character and nature of both acoustic and electric instruments as well as electronic circuits in real world environments. REMS emulates a wide variety of sound generation characteristics including instrument bodies, speakers & cabinets, acoustic fields, microphones, vacuum tubes, transistors, etc.

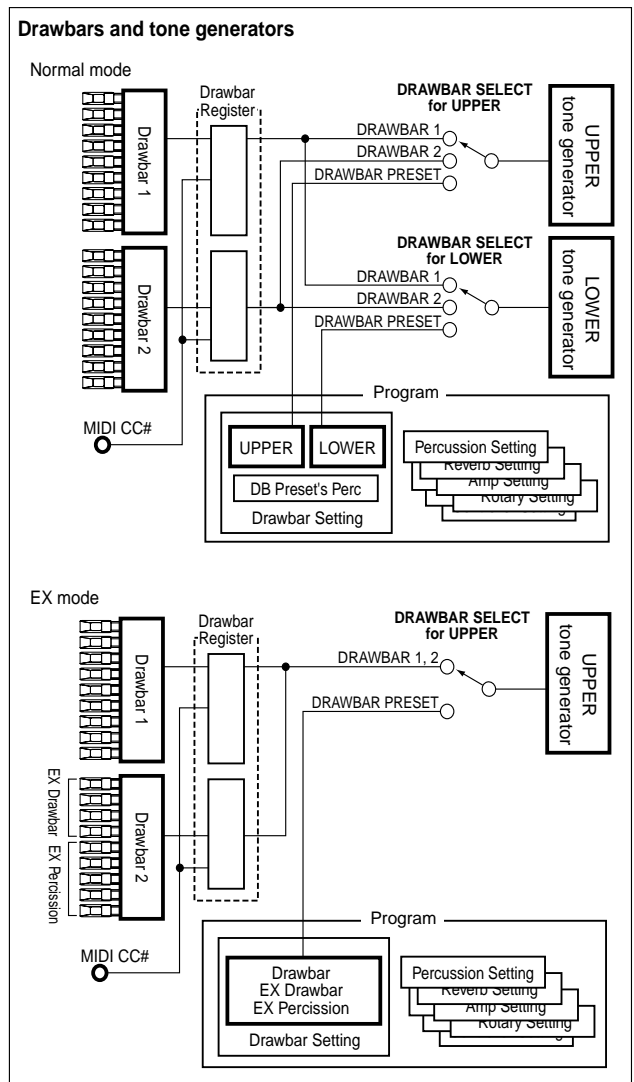

The modes of the CX-3

Normal mode and EX mode

In these modes you can select and play programs. The main differences between Normal mode and EX mode are given below.

Normal mode

- The sound is created by one set of drawbars
- The Upper tone generator and Lower tone generator can be used
- The keyboard can be split

EX mode

- The sound is created by two sets of drawbars
- The Upper tone generator is used

Normal Edit mode and EX Edit mode

Here you can edit the program parameters of Normal mode or EX mode.

Global mode

Here you can make settings that affect the entire CX-3, such as master tune, transpose, and global MIDI channel.

2. Controls and their functions

Front panel

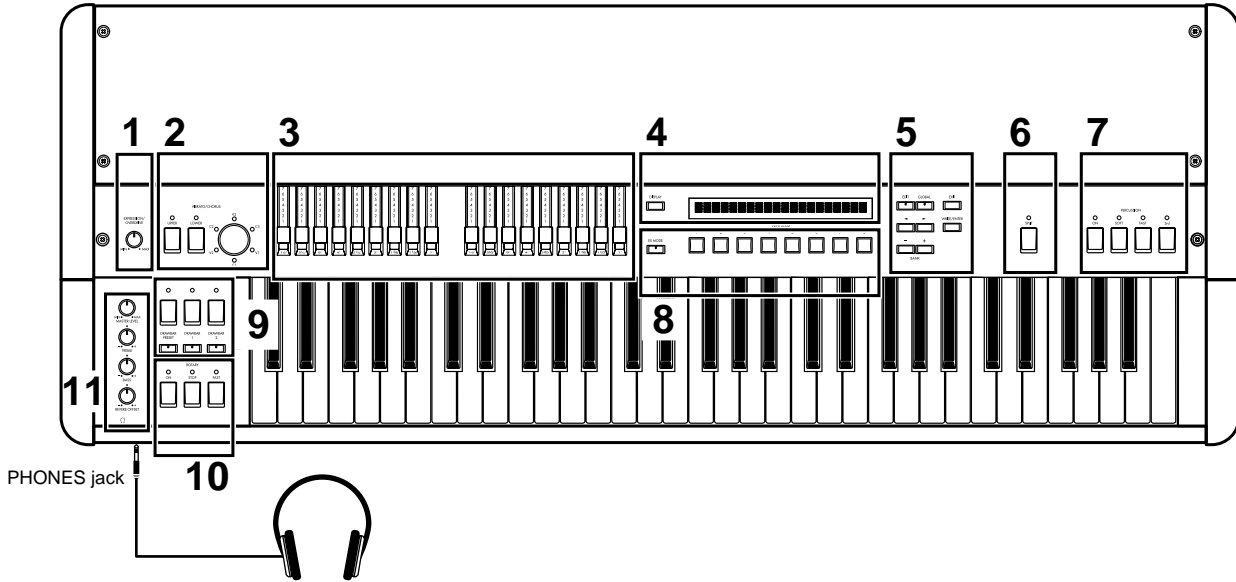

1. [EXPRESSION/OVERDRIVE] knob

This simultaneously adjusts the volume and distortion. When the volume is decreased, the low range and high range will be slightly emphasized.

2. VIBRATO/CHORUS section

[UPPER] key
[LOWER] key

These keys select the tone generator (Upper tone generator or Lower tone generator) to which vibrato or chorus will be applied. When you press the key to turn the function on, the LED will light.

[VIBRATO/CHORUS] knob

V1-V3: Vibrato will be applied, with V3 producing the maximum effect.
C1-C3: Chorus will be applied, with C3 producing the maximum effect.

3. DRAWBAR section

Drawbar 1, Drawbar 2

By pulling individual bars toward yourself you can create different sounds corresponding to the “shape” of the bars. To play using Drawbar 1 and Drawbar 2, refer to “Play using the drawbars” (p.8).

In **Normal mode and Normal Edit mode**, the sound is determined by the nine bars of either set, Drawbar 1 or 2. For more about the sound that is assigned to each drawbar, refer to “1. How the drawbars work” (p.27).

In **EX Mode and EX Edit mode**, the sound is determined by the total of eighteen bars of both sets, Drawbar 1 and 2.

The bars of **Drawbar 1** are used to create the sound in the same way as in Normal mode or Normal Edit mode. For more about the sound that is assigned to each drawbar, refer to “1. How the drawbars work” (p.27).

For **Drawbar 2**, you will use the **EX Drawbars** and **EX Percussion drawbars** to create the sound. For more about the sound that is assigned to each drawbar, refer to the EX mode section in “Play using the drawbars” (p.9), the EX Edit mode section “EX Drawbar Type” parameter (p.18), Global mode parameters “Type 1 Ex Drawbar 1” through “Type 4 Ex Drawbar 4” (p.26), and “3. Voice name list” (p.31).

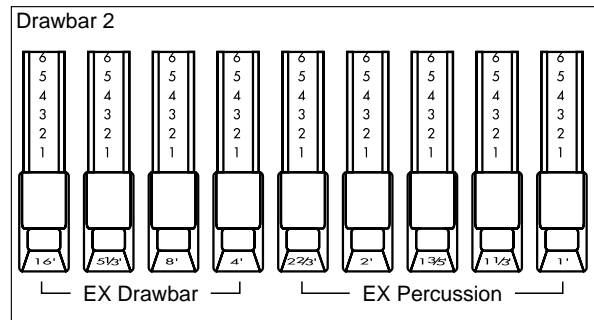

4. [DISPLAY] key (p.7)

Each time you press this key, the contents shown in the display will change.

In addition, the display will differ for Normal mode and EX mode.

5. [EDIT] key

Press this key to enter Normal Edit mode or EX Edit mode.

Pressing this key in Normal mode will enter Normal Edit mode. Pressing this key in EX mode will enter EX Edit mode.

[GLOBAL] key

Press this key to enter Global mode.

[EXIT] key

Press this key to exit Normal Edit mode, EX Edit mode, or Global mode, or to cancel an operation such as Program Write, Copy, Swap, or Data Dump without executing it.

[WRITE/ENTER] key

Press this key to execute an operation such as Program Write, Copy, Swap, or Data Dump.

[√]/[▶] keys

In Normal Edit mode, EX Edit mode and Global mode, these keys are used to move to the previous or next page, or to move the cursor to left/right in the display.

[−]/[+] keys

In Normal mode and EX mode, these keys select the preset program bank.

In Normal Edit mode, EX Edit mode, or Global mode, these keys modify the value of a parameter.

If you briefly press a key, the value will change in steps of one. If you continue holding down a key, the value will change continuously.

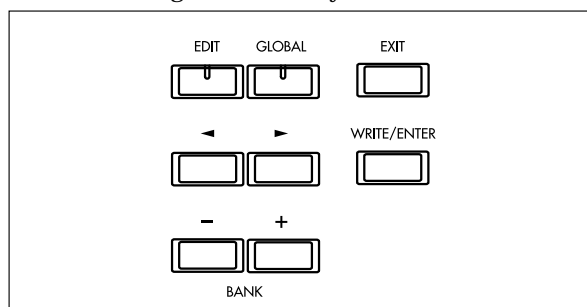

6. [SPLIT] key

In Normal mode, you can divide the keyboard into left and right areas divided at the note you specify (the “split point”).

The split point will be the highest note in the left keyboard area.

The split point can be set independently for each program.

You can change the split point by adjusting the Normal Edit mode Group 7 “Split Point” parameter.

7. PERCUSSION section

The keys in this section add an attack to the sound at the moment that the note is played, giving the notes more definition.

These keys will have an effect when the Upper tone generator is used.

For details on each key, refer to “Key settings in the PERCUSSION section” (p.12).

8. [EX MODE] key

Press this key to enter EX mode.

PROGRAM [1]–[8] keys

In Normal mode and EX mode, these keys are used to directly select preset programs (p.8).

In Normal Edit mode, EX Edit mode, and Global mode, these keys function as shortcut keys to select parameters (p.7).

9. DRAWBAR SELECT section

The three keys in the upper row are for the **Upper tone generator**, and the three keys in the lower row are for the **Lower tone generator**. When you press a key to turn it on, the LED will light.

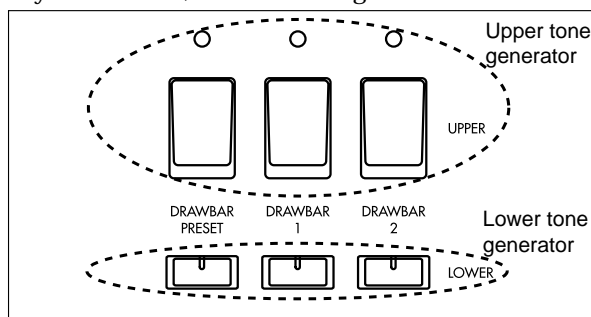

For each tone generator, these select the drawbar settings that will be used.

There are three choices of drawbar settings; the **Drawbar 1** or **Drawbar 2** settings of the front panel, or the **drawbar parameters** of the program.

UPPER/LOWER [DRAWBAR 1] key

The Drawbar 1 settings of the front panel will be used.

UPPER/LOWER [DRAWBAR 2] key

The Drawbar 2 settings of the front panel will be used.

UPPER/LOWER [DRAWBAR PRESET] key

The drawbar parameters of the program will be used. The drawbar parameters of a Normal mode program contain “UPPER” parameters and “LOWER” parameters.

The drawbar parameters of an EX mode program contain “EX Mode Drawbar Level” parameters.

To modify the drawbar parameter settings, you will use Normal Edit mode for a Normal mode program, or EX Edit mode for an EX mode program.

If the key LED is blinking or dark, pressing this key will cause the drawbar parameter settings to appear in the display for approximately one second.

10. ROTARY section

Here you can control the rotary speaker effect.
For details on each key, refer to “ROTARY section key settings” (p.13).

11. AMP section

[MASTER LEVEL] knob

This adjusts the volume.
After using the [EXPRESSION/OVERDRIVE] knob to adjust the volume and distortion, use this knob to set the final volume.

[TREBLE] knob

This knob adjusts the high frequency range.

[BASS] knob

This knob adjusts the low frequency range.

[REVERB OFFSET] knob

This knob adjusts the reverb depth.
When the knob is in the center position, the reverb depth will be as specified by the program. If the knob is turned all the way toward the left there will be no effect. If the knob is turned all the way toward the right the effect will be deeper.

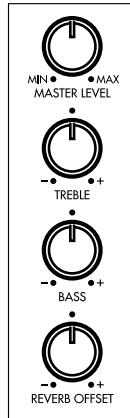

Rear panel

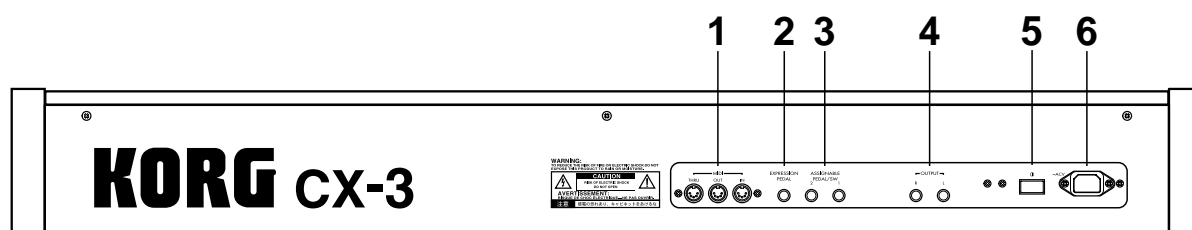
**1. MIDI IN connector**

Musical data and sound settings etc. can be received at this connector.

Use this connector when you wish to play the CX-3's tone generator from a connected MIDI device.

MIDI OUT connector

Music data and sound settings etc. can be transmitted from this connector.

Use this connector when you wish to control a connected MIDI device.

MIDI THRU connector

Music data and sound settings etc. received at the MIDI IN connector are re-transmitted without change from this connector.

Use this connector when you wish to connect multiple MIDI devices.

2. EXPRESSION PEDAL jack

Connect the included expression pedal here.

3. ASSIGNABLE PEDAL/SW 1, 2 jacks

On/off-type pedal switches (separately sold Korg PS-1 pedal switches), or separately sold Korg EXP-2 foot controllers or XVP-10 expression/volume pedals can be connected to these jacks.

4. OUTPUT L, R jacks

Connect these jacks to the INPUT jacks of your amp or mixer.

These are unbalanced phone jacks.

When connecting in stereo, use the L and R jacks.

When connecting in monaural, use the L jack.

5. Power switch

This turns the power on/off.

6. AC power inlet

Connect the included power cable here.

After connecting the power cable to the CX-3, plug it into an AC outlet.

Connections

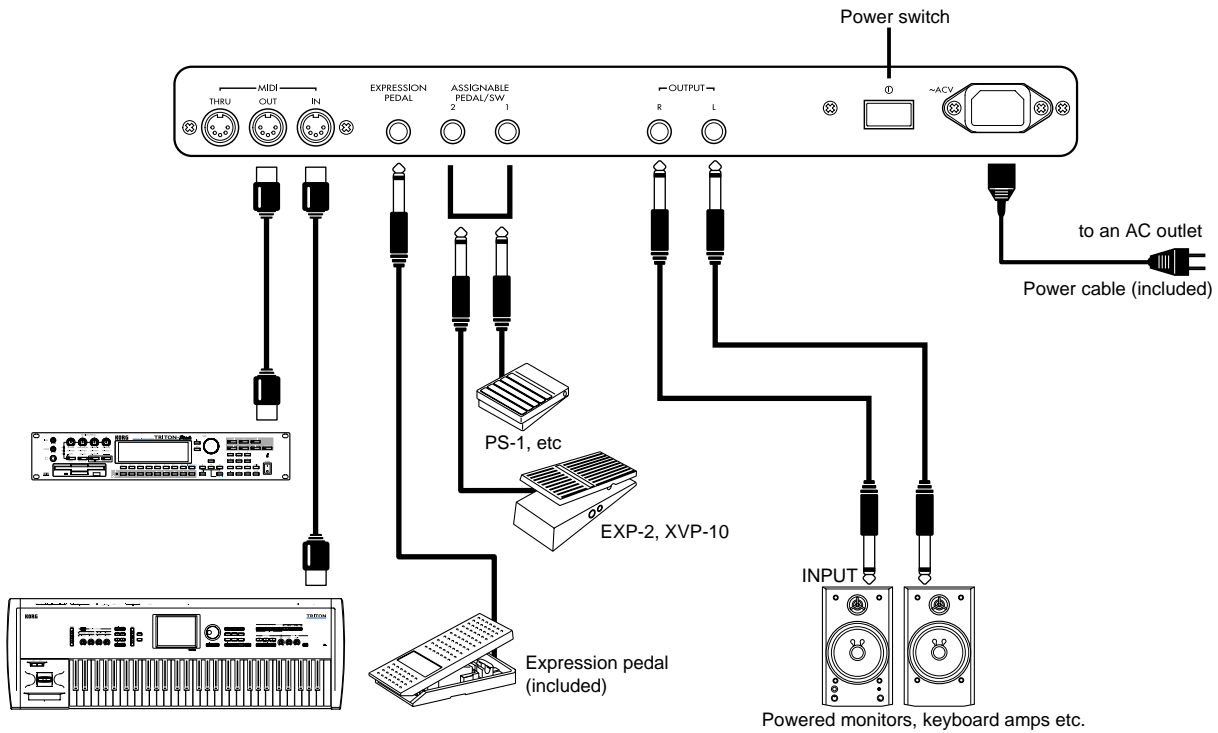

⚠ Be sure that the power is off before you make connections. Careless operation can damage your speaker system etc., or cause malfunctions.

1. Power cable connections

Connect the included power cable to the AC power inlet of the CX-3, and then plug the other end of the cable into an AC outlet.

2. OUTPUT jack connections

Connect powered monitors, keyboard amps, or your audio system to output the sound of the CX-3.

⚠ If you connect the CX-3 to a stereo audio amp, high-volume playing may damage your speaker system. Be careful not to raise the volume excessively. Connect the OUTPUT L, R jacks to the INPUT jacks of your powered monitors etc. When connecting in stereo, use the L and R jacks. When connecting in monaural, use the L jack. We recommend that you use stereo connections whenever possible.

3. Pedal connections

Pedal switch connections

The rotary speaker effect, vibrato/chorus on/off, and program selection can be controlled by a foot switch. The function to be controlled can be specified by the parameters of Normal Edit mode, EX Edit mode, and Global mode.

Connect a separately sold Korg PS-1 pedal switch to the ASSIGNABLE PEDAL/SW jack of the rear panel.

Expression pedal connections

A pedal can be used to control the volume, etc. The function to be controlled can be specified by the parameters of Normal Edit mode, EX Edit mode, and Global mode.

Connect the included expression pedal to the EXPRESSION PEDAL jack, and a separately sold Korg EXP-2 foot controller or XVP-10 expression/volume pedal to the ASSIGNABLE PEDAL/SW jack of the rear panel.

4. MIDI connections

MIDI connections allow you to use the keyboard and controllers (drawbars etc.) of the CX-3 to control an external MIDI tone generator, or use another MIDI keyboard or sequencer to play the tone generator of the CX-3.

Use a MIDI cable to connect the MIDI connector of the CX-3 to the MIDI connector of the external MIDI device. For details refer to "2. MIDI applications" (p.27).

Basic operation

1. The display screen

Switching the display

Each time you press the [DISPLAY] key, the contents of the display screen will change as shown below.

The display shows the parameter settings of the selected program.

In Normal mode

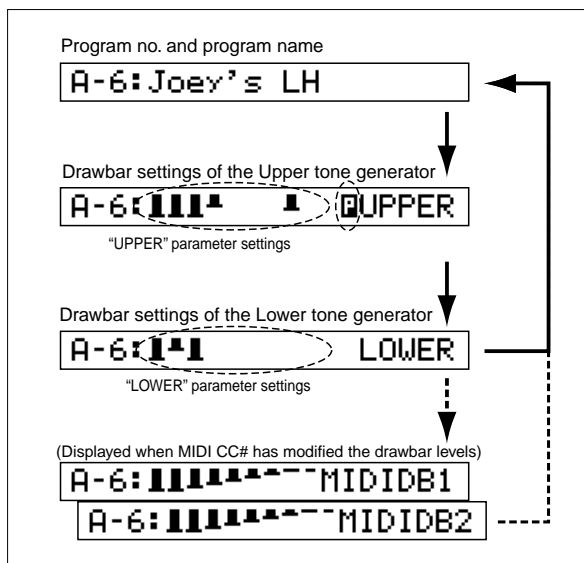

If the Drawbar 1 or 2 settings have been modified by MIDI control changes that were received, the "MIDI Drawbar 1, 2 settings" will be displayed following the "Drawbar levels of the Lower tone generator."

In EX mode

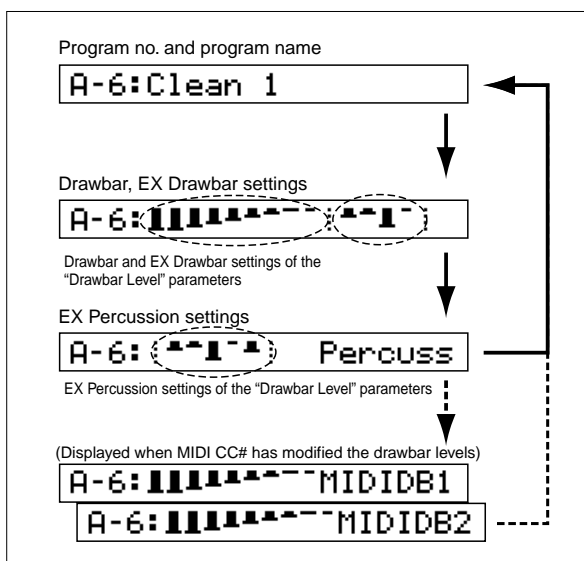

If the Drawbar 1 or 2 settings have been modified by MIDI control changes that were received, the "MIDI Drawbar 1, 2 settings" will be displayed following the "EX PERCUSSION drawbar levels."

Drawbar levels and icons



Drawbar levels

The figure above shows the drawbar levels.

For a level of 8, the display will show the bar pulled out all the way, as for the two left-most drawbars above. For a level of 0, nothing will be displayed.



Enter icon

When you are writing or copying a program, this icon will appear in the right side of the display.

This icon indicates that you should press the [WRITE/ENTER] key to execute the operation.



Speaker icon

When you are writing a program or copying data in Global mode, this icon will appear at the left of the program number.

By playing the keyboard you can audition the sound of the program indicated by this icon.



Percussion icon

This indicates that the Normal Edit mode "DB Preset's Perc" parameter is set to Ena.

If this parameter is set to Ena, selecting the UPPER [DRAWBAR PRESET] key in Normal mode allows you to use percussion. For details refer to "Percussion" (p.11).

Shortcut

In Normal Edit mode, EX Edit mode, and Global mode, pressing the PROGRAM [1]-[8] keys will make the first parameter of the corresponding group appear in the display. This is a convenient way to select parameters.

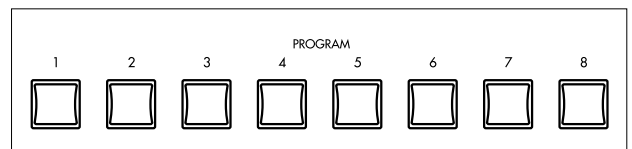

The parameters of the displayed group will depend on the mode, and correspond to Group 1 through 8. For details on the parameters that will be selected for each group, refer to "Parameters" (p.17).

2. About programs

The CX-3 has **128** preset programs (64 for Normal mode, and 64 for EX mode).

In each mode, the programs are organized as banks A–H, with eight programs in each bank.

How a program is organized

A preset program consists of the following four types of settings.

- 1) Settings for the basic organ sound
- 2) Drawbar settings
- 3) Effect settings
- 4) Front panel key settings

Each program has its own independent settings. This means that when you change programs, the settings of the selected program will take effect.

2) Drawbar settings are specified by each program as parameters, but these settings will be used only if [DRAWBAR PRESET] key is selected in the DRAWBAR SELECT section.

If you select either [DRAWBAR 1] key or [DRAWBAR 2] key in the DRAWBAR SELECT section, drawbar parameter settings will not be used; instead, the settings of the front panel Drawbar 1 and Drawbar 2 controls will be used.

4) Front panel key settings are the Group 1 “Prg. Chng” parameters of Global mode. If you select Int. Params, the front panel key settings will be used without change even when you switch programs.

Selecting a program

As an example, here’s how to select the Normal mode program C-3 (program 3 of bank C)

- 1. Make sure that you are in Normal mode.**
When you turn the power on, the CX-3 will automatically be in Normal mode.
In Normal mode, the [EX MODE] key, [EDIT] key, and [GLOBAL] key LEDs will be dark.
If the [EX MODE] key LED is lit, press the [EX MODE] key once.
If the [EDIT] key or [GLOBAL] key LED is lit, either press the lit key once or press the [EXIT] key.
- 2. Press the [+] key twice to select bank C.**
Notice that C appears at the left side of the display.
- 3. Press the PROGRAM [3] key.**
The C-3 program will be selected, and the display will show the program number and program name.

C-3: Whyter Shade

tips To select an EX mode program, verify that you are in Normal mode in step 1 and then press the [EX MODE] key. Then perform steps 2 and 3.

Now you can continue to the section “3. Playing the CX-3” that follows.

3. Playing the CX-3

Play using the drawbars

Normal mode

As an example, here’s how to play using front panel **Drawbar 2**.

We will play the sound specified by Drawbar 2 across the entire keyboard without splitting the keyboard.

- 1. Make sure that you are in Normal mode.**
For details refer to the preceding section “Selecting programs.”
- 2. In the DRAWBAR SELECT section, make sure that the UPPER [DRAWBAR 2] key LED is lit.**
If this key LED is dark, press the UPPER [DRAWBAR 2] key.

Now you can play the Upper tone generator using front panel Drawbar 2 settings.

With the factory settings, the UPPER [DRAWBAR 2] key and LOWER [DRAWBAR 1] key LEDs will be lit when you turn on the power.

tips You can set the Global mode Group 7 “Default Db Select” parameter to specify what will be selected in the DRAWBAR SELECT section when the power is turned on.

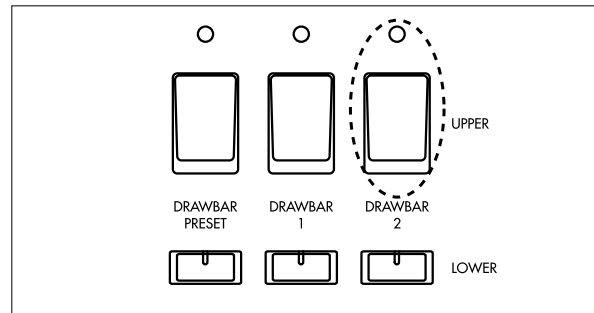

⚠ When the keyboard is not split, the Upper tone generator will be used for the entire keyboard. In this case, what you choose for the Lower tone generator in the DRAWBAR SELECT section will have no effect on the sound played from the CX-3’s keyboard.

4. Try selecting other programs.

Use the [+] and [-] keys to select the bank, and the PROGRAM [1]–[8] keys to select the number.

When you switch programs, the program parameters other than the drawbar settings will be reflected in the sound.

5. While you play, press the various keys of the PERCUSSION section to add percussion.

When you add percussion to your performance, a sense of attack will be added to the beginning of the notes you play, producing a crisper sound.

For details on percussion settings, refer to “Percussion” (p.11).

! If you play the keyboard legato, the percussion will be added only to the first note you play.

tips You can also add vibrato, chorus, or rotary speaker effects to your playing. For details refer to “4. Applying effects to your playing” (p.11).

4. If you wish to add percussion, make sure that the Normal Edit mode Group 2 “DB Preset’s Perc” parameter is set to Ena, and press the keys of the PERCUSSION section.

If this parameter is set to Dis, pressing the keys of the PERCUSSION section will have no effect.

For details on checking and setting this parameter, and on using percussion, refer to “Percussion” (p.11).

! If you play the keyboard legato, the percussion will be added only to the first note you play.

tips You can also add vibrato, chorus, or rotary speaker effects to your playing. For details refer to “4. Applying effects to your playing” (p.11).

Play using the drawbar parameter settings of a program

Here’s how to play using the drawbar parameter settings specified by the program.

! Front panel Drawbar 1 and 2 cannot be used.

Normal mode

1. Select a program in Normal mode.

Use the [+] key and [-] key to select the bank, and the PROGRAM [1]–[8] keys to select the number. For details refer to “Selecting a program” (p.8).

2. In the DRAWBAR SELECT section, press the UPPER [DRAWBAR PRESET] key to make the key LED light.

Now you can play the Upper tone generator using the parameter settings of the program you selected.

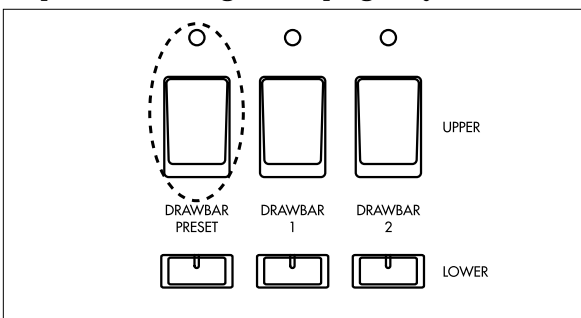

! If the keyboard is not split, the Upper tone generator will be used by the entire keyboard. In this case, the selection you make for the Lower tone generator in the DRAWBAR SELECT section will not affect the sound you play from the CX-3’s keyboard.

3. Play the keyboard.

You will play the sound that is specified by the “UPPER” parameters of the program.

EX mode

1. Select a program in EX mode.

Use the [+] key and [-] key to select the bank, and the PROGRAM [1]–[8] keys to select the number. For details refer to “Selecting a program” (p.8).

2. In the DRAWBAR SELECT section, press the UPPER [DRAWBAR PRESET] key to make the key LED light.

Now you can play using the parameter settings of the program you selected.

! In EX mode, only the Upper tone generator is used; the Lower tone generator cannot be selected.

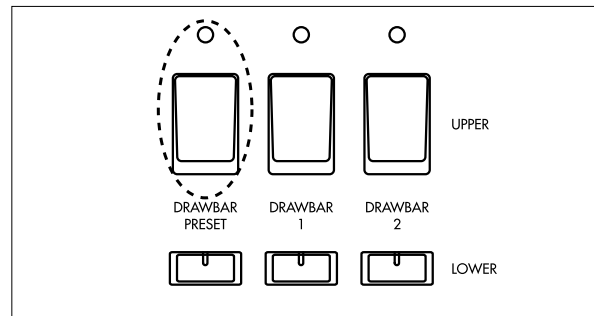

3. Play the keyboard.

You will play the sound that is specified by the “EX Mode Drawbar Level” parameters of the program.

4. You can add percussion by pressing the keys of the PERCUSSION section.

For details on percussion settings, refer to “Percussion” (p.11).

tips You can also add vibrato, chorus, or rotary speaker effects to your playing. For details refer to “4. Applying effects to your playing” (p.11).

Dividing the keyboard into left and right

In Normal mode, you can divide the keyboard into left and right to use the Upper and Lower tone generator separately, as if you were playing a two-manual keyboard.

1. Make sure that you are in Normal mode.

For details on how to check this, refer to “Selecting a program” (p.8).

2. Press the [SPLIT] key.

The key LED will light.

The keyboard of the CX-3 will be divided into two areas at the split point specified for each program. The split point will be the highest note in the left-hand keyboard area.

If you wish to change the split point, you can adjust the Normal Edit mode Group 7 “Split Point” parameter.

3. In the DRAWBAR SELECT section, press the UPPER [DRAWBAR 2] key and LOWER [DRAWBAR 1] key.

Notice that the LED of each key is lit.

Now you can use Drawbar 2 to create the sound of the right-hand keyboard area, and Drawbar 1 to create the sound of the left-hand area. The right-hand area will use the Upper tone generator, and the left-hand area will use the Lower tone generator.

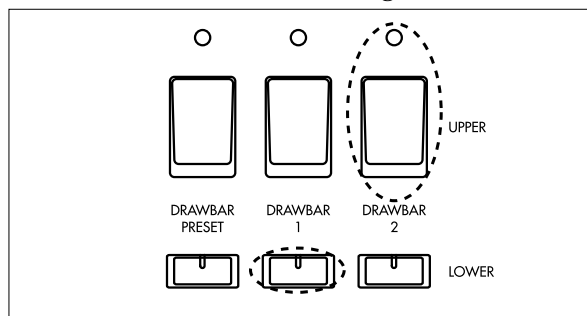

tips By selecting the UPPER [DRAWBAR 2] key, you can add the keys of the front panel PERCUSSION section to add percussion to the sound.

4. While playing the keyboard, pull out various bars of Drawbar 1 and 2 to create the sound for the left and right-hand areas.

tips In step 3, you can press the UPPER [DRAWBAR PRESET] key or the LOWER [DRAWBAR PRESET] key to play using the drawbar settings of the program. In this case, you will need to set the Normal Edit mode Group 2 “DB Preset’s Perc” parameter to Ena if you wish to add percussion.

In this way, you can use various combinations of the DRAWBAR PRESET section to select and play different drawbar settings.

tips You can set the left and right-hand areas to the same pitch range. To do so, use the Normal Edit mode Group 7 “Split Upper Octave” parameter and “Split Lower Octave” parameter.

4. Applying effects to your performance

Percussion

You can use the keys and drawbars of the front panel PERCUSSION section to add percussion to your performance.

Percussion adds an attack to the beginning of the note, giving the sound more crispness. However when the keyboard is played legato, percussion will be added only to the first note you play.

Normal mode

When performing with the drawbars

You must select the UPPER [DRAWBAR 2] key in the DRAWBAR SELECT section (the key LED will light).

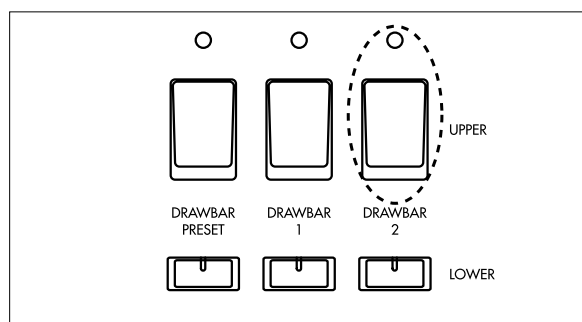

When you play using Drawbar 2 of the front panel, percussion can be added by operating the keys of the PERCUSSION section.

When playing a program

Set the “DB Preset’s Perc” parameter to Ena.

When playing the drawbar settings of a program, percussion can be added by operating the keys of the PERCUSSION section.

▲ Since the “DB Preset’s Perc” parameter can be set independently for each program, you must use the following procedure to check the setting after you select a program.

■ How to check the “DB Preset’s Perc” parameter

1. In Normal mode, make sure that the display shows the program name.
If the program name is not shown in the display, press the [DISPLAY] key several times.
2. Press the [DISPLAY] key once, and check whether the Percussion icon is shown at the right of UPPER in the display.

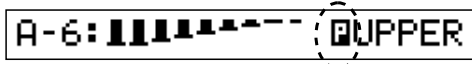

The Percussion icon is displayed to indicate that the “DB Preset’s Perc” parameter is set to **Ena**.

■ How to set the “DB Preset’s Perc” parameter

1. In Normal mode, press the [EDIT] key.
You will enter Normal Edit mode.
2. Press the PROGRAM [2] key, and then press the [▶] key twice.
The “DB Preset’s Perc” parameter will appear.
3. Press the [-] key or [+] key to set the value to **Ena**.
4. Press the [EXIT] key to return to Normal mode.

EX mode

When you are playing a program, you can always operate the keys of the PERCUSSION section to add percussion. There is no need to check or make settings.

Playing the dawbar settings

In addition to operating the keys of the front panel PERCUSSION section, you can also use EX Percussion (the five bars at the right of Drawbar 2).

Operations of the PERCUSSION section keys will produce the same effects as in Normal mode.

The various EX Percussion bars will control the percussion that is assigned to each bar. For details on what is assigned to each bar, refer to “3. Playing the CX-3” (p.8) and “3. Voice name list” (p.31).

Playing a program

The volume of the percussion is set by the EX Edit mode Group 2 “EX Drawbar Type” parameter.

Key settings of the PERCUSSION section

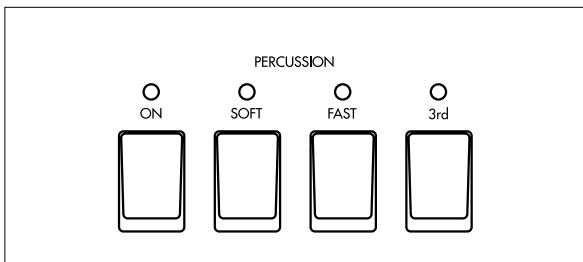

[ON] key

This key switches the percussion on/off. If this is off, pressing the [3rd] key, [SOFT] key, or [FAST] key will produce no effect.

ON (LED lit): Percussion will be on.

🔊 In Normal mode when percussion is on, there will be no 1' sound.

[SOFT] key

This key switches the percussion volume (soft or normal).

SOFT (LED lit): The volume of the percussion will be less than when Normal is selected.

The soft and normal volumes can be adjusted by the Normal Edit mode or EX Edit mode Group 3 “Perc Norm Level” parameter and “Perc Soft Offset” parameter.

[FAST] key

This key switches the percussion decay speed (fast or slow).

FAST (LED lit): The decay will be faster than when Slow is selected.

The fast and slow decay times can be adjusted by the Normal Edit mode or EX Edit mode Group 3 “Perc Fast Decay” parameter and the “Perc Slow Offset” parameter.

[3rd] key

This key switches the percussion pitch (3rd or 2nd). This setting is assigned to 2-2/3' of EX Percussion (the five bars at the right of Drawbar 2) when you play using the EX mode drawbars.

3rd (LED lit): A pitch one octave and a fifth higher (corresponding to 2-2/3') will be output simultaneously with the note you play.

2nd (LED dark): A pitch one octave higher (corresponding to 4') will be output simultaneously with the note you play.

Vibrato and chorus

You can apply vibrato or chorus to the sound.

1. Use the [UPPER] key and [LOWER] key to select the tone generator (Upper tone generator, Lower tone generator) to which you will apply vibrato or chorus.

2. Use the [VIBRATO/CHORUS] knob to select either vibrato or chorus.

V1-V3: Vibrato will be applied. V3 produces the maximum effect.

C1-C3: Chorus will be applied. C3 produces the maximum effect.

Rotary speaker

The rotary speaker effect applies modulation to the sound.

🔊 In order to use the rotary speaker, you must set the “Amp Type” parameter of the program (Normal Edit mode or EX Edit mode Group 4) to **Type 1** or **Type 2**.

For programs in which the “Amp Type” parameter is set to Pre Amp, there will be no effect even if you press the [ON] key in the ROTARY section. When you press the [ON] key, the LED will blink three times, and then go dark. However, you will still be able to set the [STOP] key and [FAST] key, so that you can make these settings even for a program for which Type 1 or Type 2 is selected.

Key settings of the ROTARY section

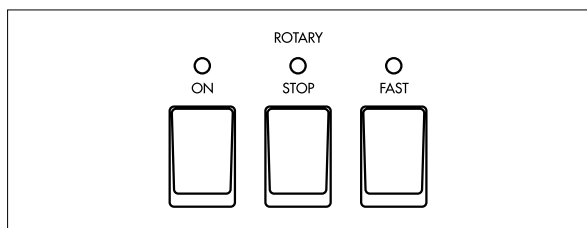

[ON] key

This key switches the rotary speaker on/off. If this is off, pressing the [FAST] key or [STOP] key will have no effect.

ON (LED lit): The rotary speaker will be on.

[STOP] key

This key starts or stops the rotation of the rotary speaker's rotor and horn.

Stop (LED lit): The rotation will gradually slow down and stop.

[FAST] key

This key switches the rotational speed of the rotary speaker (fast and slow).

Fast (LED lit): The rotation will speed up. If the [STOP] key was used to stop the rotation, pressing the [FAST] key will defeat the setting of the [STOP] key, and rotation will begin. (The [STOP] key LED will go dark.)

tips The fast and slow rotational speeds, the time over which rotation changes from fast to slow, the time over which rotation changes from slow to fast, the speed and time for the rotor and horn of the rotary speaker, and the time until rotation stops after it is switched off etc. can all be adjusted by the Normal Edit mode and EX Edit mode Group 6 parameters (p.19).

Other effects

In addition to the effects described above, you can use the knobs and keys of the front panel to modify the sound in various ways.

Overdrive

The [EXPRESSION/OVERDRIVE] knob adjusts the depth of overdrive. This will also affect the volume.

The [EXPRESSION/OVERDRIVE] knob adjusts the output level of the tone generator, changing the input level to the internal amp simulation.

The effect can be adjusted by controlling Overdrive in conjunction with the "Amp Gain" parameter (p.19) of the amp simulator.

Reverb

The [REVERB OFFSET] knob adjusts the depth of reverb.

When the knob is in the center position, the reverb depth will be as specified by the settings of the program. The reverb depth can be adjusted by the Normal Edit mode and EX Edit mode Group 5 "Reverb Mix Level" parameters.

5. Listening to the demo songs

Here's how to listen to the demo songs built into the CX-3.

The CX-3 contains 9 demo songs.

1. Press the [GLOBAL] key to enter Global mode. The key LED will light.
2. Press the PROGRAM [8].
3. Press the [WRITE/ENTER] key.
4. Press the [WRITE/ENTER] key once again. The demo will begin playing. When the first song ends, the next song will begin.
5. To stop demo playback, press the [EXIT] key.

tips After pressing the [WRITE/ENTER] key in step 3, you can press the [√] or [▶] key to change the song that will be played first.

6. Editing a program

You can edit the sound or name of the selected program.

When editing a program, it is a good idea to start by selecting the program that is closest to the sound you want.

This section provides several examples of editing that you can do easily.

Editing the drawbar parameters

You can use front panel Drawbar 1 or 2 to modify the drawbar parameter settings of a program.

In the following example, we will modify the parameters of a Normal mode program.

1. In Normal mode, select a program.

Use the [-]/[+] keys to select a program, and use the PROGRAM [1]–[8] keys to select the number of the program you wish to edit.

Notice that the display shows the program number and program name.

2. Press the [EDIT] key.

You will enter Normal Edit mode.

3. Press the PROGRAM [2] key.

The left side of the display will indicate UPPER, and the “UPPER” parameter settings will appear at the right.

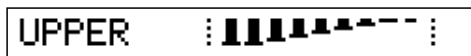

4. Make sure that the UPPER [DRAWBAR PRESET] key LED is lit.

If it is blinking, press the UPPER [DRAWBAR PRESET] key.

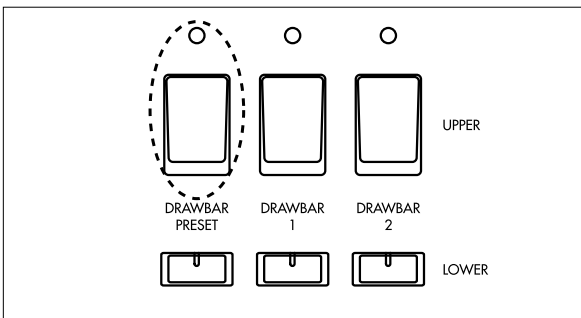

5. Move the Drawbar 1 or Drawbar 2 bars (you may use either) to set the drawbar parameters.

The value of the bar you move will be input as the parameter value, and the display will change accordingly.

6. To return to Normal mode, press the [EXIT] key.

 If you select another program or turn off the power before writing the modified settings, the settings will revert to their previous values. If you wish to write your settings into memory, refer to “Writing a program” (p.15).

Copying drawbar parameters

The Drawbar 1 or Drawbar 2 settings can be copied directly into the “UPPER” parameters or “LOWER” parameters of a program.

As an example, here’s how you can use front panel Drawbar 1 to create a sound, and then copy those settings to the “UPPER” parameters of the program.

1. In Normal mode, select a program.

Use the [-]/[+] keys to select a program, and use the PROGRAM [1]–[8] keys to select the number of the program you wish to edit.

Notice that the display shows the program number and program name.

2. In the DRAWBAR SELECT section, press the UPPER [DRAWBAR 1] key.

Notice that the key LED is lit.

3. While playing the keyboard, use the bars of Drawbar 1 to create the desired sound.

4. Hold down the UPPER [DRAWBAR 1] key, and press the UPPER [DRAWBAR PRESET] key.

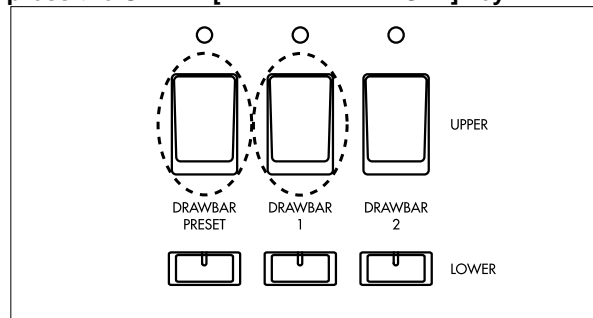

The Drawbar 1 bar settings will be copied to the “UPPER” parameters, and an “*” will be displayed between the program number and the program name.

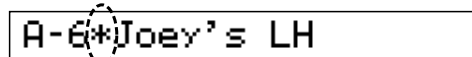

tips If you wish to verify that the settings have been changed, press the [DISPLAY] key once when the program name is displayed. The drawbar settings will appear in the display.

Alternatively, you can use the [EDIT] key to enter Normal Edit mode, and press the PROGRAM [2] key to view the settings.

 If you select another program or turn off the power before writing the modified settings, the settings will revert to their previous values. If you wish to write your settings into memory, refer to “Writing a program” (p.15).

tips Drawbar parameters can also be copied in EX mode.

In step 1, select an EX mode program.
In step 2, press the UPPER [DRAWBAR 1] key or the UPPER [DRAWBAR 2] key, and use the respective bars to create the desired sound.

In step 4, hold down either the UPPER [DRAWBAR 1] key or the UPPER [DRAWBAR 2] key, and press the UPPER [DRAWBAR PRESET] key.

 If you select another program or turn off the power before writing the modified settings, the settings will revert to their previous values. If you wish to write your settings into memory, refer to “Writing a program” (p.15).

Parameters unique to a combo organ

The CX-3 has various parameters for simulating the distinctive sound of a combo organ.

As an example, here's how to edit the tone wheel, overtone, key click level, and leakage level.

1. **Press the [EDIT] key to enter Normal Edit mode or EX Edit mode.**
2. **Press the [$\sqrt{\quad}$] key or [▶] key to access the "Wheel Type" parameter.**
If this parameter does not appear immediately, press the PROGRAM [1] key and then press the [▶] key once.
This parameter selects the type of tone wheel. **The tone wheel** is the sound-producing mechanism used by the tone generator of combo organs.
3. **Press the [-] or [+] key to select Vintage.**
Vintage includes leakage noise. This is mechanical noise created by the tone wheel, and is unique to combo organs.
Clean does not include leakage noise.
4. **Press the [▶] once to access the "Over Tone Level" parameter, and use the [-]/[+] keys to adjust the value.**
This parameter adjusts the level of the overtones produced by the tone wheel. Increasing this value will increase the volume.
5. **Press the [▶] key once to access the "Leakage Level" parameter, and use the [-]/[+] keys to adjust the value.**
This parameter adjusts the amount of noise (unrelated to the keyboard) that is combined with the tone wheel signal. Increasing this value will increase the noise.
6. **Press the [▶] key once to access the "On Click Level" parameter, and use the [-]/[+] keys to adjust the value.**
This parameter simulates the noise that is produced when you play a note, and adjusts the level of this noise. Increasing this value will increase the noise.
7. **Press the [▶] key once to access the "Off Click Level" parameter, use the [-]/[+] keys to adjust the value.**
This parameter simulates the noise that is produced when you release a note, and adjusts the level of this noise. Increasing this value will increase the noise.

 If you select another program or turn off the power before writing the modified settings, the settings will revert to their previous values. If you wish to write your settings into memory, refer to "Writing a program" (p.15).

Other editing

The CX-3 has parameters that add various effects to the sound. Each of the factory-set programs has effect settings that are appropriate for their sound.

If you wish to make detailed adjustments to the sound of a program, you can edit these parameters in Normal Edit mode or EX Edit mode.

- Percussion settings:** Group 3 (p.18)
- Amp settings:** Group 4 (p.19)
- Reverb settings:** Group 5 (p.19)
- Rotary speaker settings:** Group 6 (p.19)

Writing a program

When you select a program, the program data is called into a **edit buffer** inside the CX-3. Then when you use Normal Edit mode or EX Edit mode to modify the parameter values, the data within the edit buffer will be modified.

If you wish to save the modified data into internal memory, you must perform the **Write** operation.

When the data in the edit buffer has been modified, an "✱" will appear between the program number and the program name.

 If you select another program before writing the program you modified, new data will be called into the edit buffer, and your modified data will be lost. The data in the edit buffer will also be lost when you turn off the power.

1. **Press the [WRITE/ENTER] key.**
The mode does not matter.
The left side of the display will indicate **WRITE.**, and the writing destination program number will be shown in the square brackets [] at the right.

```
WRITE. 4A-2 to [A-2]✱
```

2. **If you wish to change the writing destination, use the [-]/[+] keys to specify the desired writing destination.**

tips You can play the keyboard to audition the sound of the program marked by the **Speaker icon**. The **Speaker icon** can be moved using the [$\sqrt{\quad}$] [▶] keys, allowing you to compare or confirm the sounds of the program you are about to write and the program that will be overwritten.

3. **Press the [WRITE/ENTER] key.**
A message will ask you to confirm the writing destination you specified.
4. **To write the data, press the [WRITE/ENTER] key. To cancel without writing, press the [EXIT] key.**
When the data has been written, the display will indicate **Completed**.

■ **Changing the program name when you save**

You can modify the program name when you save. If you wish to do so, use the following procedure **before step 1 of the Writing procedure.**

1. Press the [EDIT] key to enter Normal Edit mode or EX Edit mode.
2. Press the PROGRAM [8] key.
The display will show **Rename** in the left side of the screen.
The program name will be displayed in square brackets [].
3. Use the [√] [▶] keys to select the character that you wish to change.
4. Use the [-]/[+] keys to specify the desired character.
You can assign a name of up to twelve characters.

	!	"	#	\$	%	&	'	()	*	+	,	-	.
/	0	1	2	3	4	5	6	7	8	9	:	;	<	=
>	?	@	A	B	C	D	E	F	G	H	I	J	K	L
M	N	O	P	Q	R	S	T	U	V	W	X	Y	Z	[
¥]	^	_	`	a	b	c	d	e	f	g	h	i	j
k	l	m	n	o	p	q	r	s	t	u	v	w	x	y
z	{		}	~										

Writing global settings

If you have modified Global mode parameters and want to save these settings in the internal memory of the CX-3, you must Write them.

If you turn off the power before writing these settings, they will revert to their previous values.

1. Press the [WRITE/ENTER] key.
The mode does not matter.
The left side of the display will indicate **WRITE**. The writing destination program number will be displayed in square brackets [] at the right, but in this case you do not need to specify this.
2. Press the [GLOBAL] key.
A message will ask you to confirm the Write operation.
3. To write the data, press the [WRITE/ENTER] key. To cancel without writing, press the [EXIT] key.
When the data has been written, the display will indicate **Completed**.

Copying a program

This function is convenient when you wish to create several variations of a program by slightly modifying the parameter settings.

1. Press the [GLOBAL] key to enter Global mode.

2. Press the PROGRAM [7] key, and then press the [▶] key once.

The left side of the display will indicate **Copy**. The copy source program number will be displayed at the right of this, and at the far right the copy destination program number will be displayed in square brackets [].

COPY A-2 -> ◀[A-2] ▶

3. If you wish to change the copy destination, use the [-]/[+] keys to specify the program number.

tips You can play the keyboard to audition the sound of the copy destination program.

4. If you wish to change the copy destination, press the [▶] key once, and then use the [-]/[+] keys to specify the program number.

tips You can play the keyboard to audition the sound of the copy source program.

5. Press the [WRITE/ENTER] key.

A message will ask you to confirm the Copy operation.

6. To copy the data, press the [WRITE/ENTER] key. To cancel without copying, press the [EXIT] key.

When the data has been copied, the display will indicate **Completed**.

Returning a program to the factory settings

You can use the following procedure to return a program to the factory settings, for example if you overwrite a program accidentally.

 When you perform this procedure, all parameters that make up that program will be reset to the factory settings.

1. Press the [GLOBAL] key to enter Global mode.
2. Press the PROGRAM [7] key, and then press the [▶] key five times.
The display will indicate Init Prog.
3. Use the [-]/[+] keys to select the program number that you wish to return to the factory settings.
You can play the keyboard to audition the sound of the selected program.
4. Press the [WRITE/ENTER] key.
A message will ask you to confirm that you want to return this program to the factory settings.
5. To return the program to the factory settings, press the [WRITE/ENTER] key. To cancel, press the [EXIT] key.

When the operation is finished, the display will indicate **Completed**.

Parameters

1. Normal Edit mode / EX Edit mode

tips When you press a PROGRAM [1]–[8] key in Normal Edit mode or EX Edit mode, the first parameter in the Group 1–Group 8 listed below will be selected directly.

Group 1

Set the output level, tone wheel, and click level.

Group 2

Set the drawbar levels for the Upper tone generator and the Lower tone generator. The displayed parameters will differ between Normal Edit mode and EX Edit mode.

Group 3

Specify how the keys of the PERCUSSION section will function.

Group 4

Adjust the amp settings.

Group 5

Adjust the reverb settings.

Group 6

Adjust the rotary speaker settings.

Group 7

Set the split point, and specify the function of the pedal connected to the ASSIGNABLE PEDAL/SW jack. The displayed parameters will differ between Normal Edit mode and EX Edit mode.

Group 8

Change the program name.

Group 1

Output Level [0...127]
Specify the output level of the program.

Wheel Type [Vintage, Clean]
Select the type of tone wheel.
Vintage: A tone wheel with leakage noise.
Clean: A tone wheel without leakage noise.

Over Tone Level [0...99]
Specify the overtone level of the tone wheel.

Leakage Level [0...99]
Specify the level of the leakage noise.

On Click Level [0...99]
Specify the level of the click noise at key-on.

Off Click Level [0...99]
Specify the level of the click noise at key-off.

Group 2

UPPER (Upper Drawbar Level) [0...8]
This parameter is displayed in Normal Edit mode.



Specify the level for each drawbar used by the Upper tone generator. From the left, the display corresponds to the 16', 5-1/3', 8', 4', 2-2/3', 2', 1-3/5', 1-1/3', and 1' bars.

When a bar is pulled out all the way, its level will be 8.

In Normal mode, pressing the [DISPLAY] key once when the program name is displayed will show the levels that you specified here.

tips The front panel Drawbar 1 or Drawbar 2 settings can be copied instantly to the parameters of a program. For details refer to “Copying drawbar parameters” (p.14).

LOWER (Lower Drawbar Level) [0...8]

This parameter is displayed in Normal Edit mode. Specify the level for each drawbar used by the Lower tone generator. From the left, the display corresponds to the 16', 5-1/3', 8', 4', 2-2/3', 2', 1-3/5', 1-1/3', and 1' bars.

When a bar is pulled out all the way, its level will be 8.

In Normal mode, pressing the [DISPLAY] key twice when the program name is displayed will show the levels that you specified here.

tips The front panel Drawbar 1 or Drawbar 2 settings can be copied instantly to the parameters of a program. For details refer to “Copying drawbar parameters” (p.14).

.....
Group 4

Amp Type [Type 1, Type 2, Pre Amp]

Select the type of amp.

Type 1: A standard powered amp for organ, producing a mild and fat tone.

Type 2: This emphasizes the high range more than Type 1, producing an uncolored tone.

Pre Amp: The pre-amp will be used. This is the sound of a direct line-out from the organ.

tips If you select **Type 1** or **Type 2**, using the front panel ROTARY section [ON] key to turn the rotary speaker on will simulate using a rotary speaker. If you turn this off, a standard speaker will be simulated.

If you select **Pre Amp**, the powered amp and rotary speaker will not be used; the sound will be that of a line-out connection from the organ itself.

Amp Gain [0...99]

Adjust the gain (amplification) when the "Amp Type" parameter is set to Type 1 or Type 2.

With high settings of this value, the sound will be distorted more severely when expression/overdrive is raised.

▲ This setting will not be used if the "Amp Type" parameter is set to Pre Amp.

Tone Treble [-10...+10]

Adjust the high frequency range of the amp selected by the "Amp Type" parameter.

Tone Middle [-10...+10]

The mid-frequency range of the amp selected by the "Amp Type" parameter.

Tone Bass [-10...+10]

Adjust the low frequency range of the amp selected by the "Amp Type" parameter.

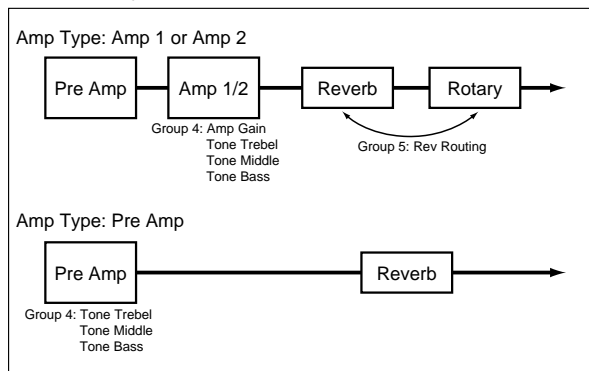

.....
Group 5

Reverb Type [Room, Hall, Plate]

Select the type of reverb.

Reverb Time [00.25...16.00 (Sec)]

Adjust the reverb time.

▲ The range in which the reverb time can be set will depend on what is selected for the "Reverb Type" parameter.

Reverb Mix Level [0...99]

Adjust the amount of reverb.

Rev Routing (Reverb Routing) [Rot->Rev, Rev->Rot]

Specify whether the reverb will be placed before or after the rotary speaker.

Rot -> Rev: The reverb effect will be applied after the rotary speaker.

Rev -> Rot: The reverb effect will be applied before the rotary speaker.

▲ This setting is not used if the "Amp Type" parameter is set to Pre Amp.

.....
Group 6

▲ These settings are not used if the "Amp Type" parameter is set to Pre Amp.

Horn: 0 Rotor: 100 (Rotary Horn/Rotor Balance) [0:100...100:0]

Adjust the volume balance between the horn and the rotor of the rotary speaker.

Horn Slow Speed [0...99]

Adjust the slow rotational speed of the horn.

Horn Fast Speed [0...99]

Adjust the fast rotational speed of the horn.

Rotor Slow Speed [0...99]

Adjust the slow rotational speed of the rotor.

Rotor Fast Speed [0...99]

Adjust the fast rotational speed of the horn.

Horn Up Transit (Horn Up Transition) [0...99]

Adjust the time over which the horn rotation changes from slow to fast.

Horn Down Transit (Horn Down Transition) [0...99]

Adjust the time over which the horn rotation changes from fast to slow.

Horn Stop Transit (Horn Stop Transition) [0...99]

Adjust the time over which the horn rotation actually comes to a stop after you stop the rotation.

Horn Strt Transit (Horn Start Transition) [0...99]

Adjust the time over which the horn reaches the specified speed after it begins to rotate.

2. Global mode

tips In Global mode you can press PROGRAM [1]–[8] keys to directly select the first parameter in Group 1–Group 8 as listed below.

Group 1

Set the master tuning, and the expression pedal and pedal switch functions.

Group 2

Set the MIDI channel.

Group 3

Set the velocity value of MIDI note messages, and the pitch bend range.

Group 4

Set MIDI filters.

Group 5

Set the MIDI control change numbers used to transmit and receive drawbar settings.

Group 6

Set the MIDI control change numbers assigned to front panel keys and to connected pedals.

Group 7

Copy, swap, initialize programs, and dump data.

Group 8

Play the demo songs.

Group 1

Master Tune [–430.0Hz...+450.0Hz]

This adjust the overall pitch of the entire CX-3 in 0.2 Hz steps, relative to the reference pitch of A4 (middle of A).

Transpose [–12...+12]

Adjust the pitch in semitone steps over a range of ± 1 octave.

Exp Minimum Level (Expression Minimum Level) [0...30]

Specify the minimum level when the expression pedal etc. is operated.

This will be the volume when the controller selected by the “Exp Control” parameter is at its minimum level.

Exp Control (Expression Controller) [Both, Knob, Pedal]

Both: The front panel [EXPRESSION/OVERDRIVE] knob and the expression pedal etc. connected to the rear panel EXPRESSION PEDAL jack will both control the volume. These two will function simultaneously.

Knob: The [EXPRESSION/OVERDRIVE] knob will control the volume.

Pedal: The expression pedal connected to the rear panel EXPRESSION PEDAL jack will control the volume.

Prog Up Ctrl (Program Up Controller)

[Off, Pedal 1/(Pdl 1), Pedal 2/(Pdl 2)]

Pedal 1: A pedal switch connected to the rear panel ASSIGNABLE PEDAL/SW 1 jack can be used to switch programs. When you press the pedal switch, the program number will be incremented in steps of one.

Pedal 2: A pedal switch connected to the rear panel ASSIGNABLE PEDAL/SW 2 jack can be used to perform the above function.

Off: No function.

(Pdl 1), (Pdl 2): This indicates that the same pedal switch is selected for the “Prog Down Ctrl” parameter described below. Please select a different pedal switch.

 If the same pedal switch as selected for this parameter is also selected for a Normal Edit mode or EX Edit mode parameter, this (Global mode) setting will take priority, and the Normal Edit mode or EX Edit mode setting will be ignored.

Prog Down Ctrl (Program Down Controller)

[Off, Pedal 1/(Pdl 1), Pedal 2/(Pdl 2)]

Pedal 1: A pedal switch connected to the rear panel ASSIGNABLE PEDAL/SW 1 jack can be used to switch programs. When you press the pedal switch, the program number will be decremented in steps of one.

Pedal 2: A pedal switch connected to the rear panel ASSIGNABLE PEDAL/SW 2 jack can be used to perform the above function.

Off: No function.

(Pdl 1), (Pdl 2): This indicates that the same pedal switch is selected for the “Prog Down Ctrl” parameter described above. Please select a different pedal switch.

 If the same pedal switch as selected for this parameter is also selected for a Normal Edit mode or EX Edit mode parameter, this (Global mode) setting will take priority, and the Normal Edit mode or EX Edit mode setting will be ignored.

Merge Lower Msg (Merge Lower Message) [Off, On]
On: MIDI messages of the channel specified by the Global mode Group 2 “MIDI Lower Rx Ch” parameter will be converted to the channel specified by the Global mode Group 2 “MIDI Lower Tx Ch” and transmitted.



Group 5

CC# Upper DB Sel (MIDI Control Change Assign for Upper Drawbar Select) [1...31, 33...95, Off]
 Specify the MIDI control change number that will be used to transmit and receive the UPPER setting of the DRAWBAR SELECT section. (The factory setting is 79.)

CC# Lower DB Sel (MIDI Control Change Assign for Lower Drawbar Select) [1...31, 33...95, Off]
 Specify the MIDI control change number that will be used to transmit and receive the LOWER setting of the DRAWBAR SELECT section. (The factory setting is 80.)

CC# DB1-1 (MIDI Control Change Assign for Drawbar 1-16') [1...31, 33...95, Off]
 Specify the MIDI control change number that will be used to transmit and receive the 16' setting of Drawbar 1. (The factory setting is 16.)

CC# DB1-2 (MIDI Control Change Assign for Drawbar 1-5-1/3') [1...31, 33...95, Off]
 Specify the MIDI control change number that will be used to transmit and receive the 5-1/3' setting of Drawbar 1. (The factory setting is 17.)

CC# DB1-3 (MIDI Control Change Assign for Drawbar 1-8') [1...31, 33...95, Off]
 Specify the MIDI control change number that will be used to transmit and receive the 8' setting of Drawbar 1. (The factory setting is 18.)

CC# DB1-4 (MIDI Control Change Assign for Drawbar 1-4') [1...31, 33...95, Off]
 Specify the MIDI control change number that will be used to transmit and receive the 4' setting of Drawbar 1. (The factory setting is 19.)

CC# DB1-5 (MIDI Control Change Assign for Drawbar 1-2-2/3') [1...31, 33...95, Off]
 Specify the MIDI control change number that will be used to transmit and receive the 2-2/3' setting of Drawbar 1. (The factory setting is 20.)

CC# DB1-6 (MIDI Control Change Assign for Drawbar 1-2') [1...31, 33...95, Off]
 Specify the MIDI control change number that will be used to transmit and receive the 2' setting of Drawbar 1. (The factory setting is 21.)

CC# DB1-7 (MIDI Control Change Assign for Drawbar 1-1-3/5') [1...31, 33...95, Off]
 Specify the MIDI control change number that will be used to transmit and receive the 1-3/5' setting of Drawbar 1. (The factory setting is 22.)

CC# DB1-8 (MIDI Control Change Assign for Drawbar 1-1-1/3') [1...31, 33...95, Off]
 Specify the MIDI control change number that will be used to transmit and receive the 1-1/3' setting of Drawbar 1. (The factory setting is 23.)

CC# DB1-9 (MIDI Control Change Assign for Drawbar 1-1') [1...31, 33...95, Off]
 Specify the MIDI control change number that will be used to transmit and receive the 1' setting of Drawbar 1. (The factory setting is 24.)

CC# DB2-1 (MIDI Control Change Assign for Drawbar 2-16') [1...31, 33...95, Off]
 Specify the MIDI control change number that will be used to transmit and receive the 16' setting of Drawbar 2. (The factory setting is 70.)

CC# DB2-2 (MIDI Control Change Assign for Drawbar 2-5-1/3') [1...31, 33...95, Off]
 Specify the MIDI control change number that will be used to transmit and receive the 5-1/3' setting of Drawbar 2. (The factory setting is 71.)

CC# DB2-3 (MIDI Control Change Assign for Drawbar 2-8') [1...31, 33...95, Off]
 Specify the MIDI control change number that will be used to transmit and receive the 8' setting of Drawbar 2. (The factory setting is 72.)

CC# DB2-4 (MIDI Control Change Assign for Drawbar 2-4') [1...31, 33...95, Off]
 Specify the MIDI control change number that will be used to transmit and receive the 4' setting of Drawbar 2. (The factory setting is 73.)

CC# DB2-5 (MIDI Control Change Assign for Drawbar 2-2-2/3') [1...31, 33...95, Off]
 Specify the MIDI control change number that will be used to transmit and receive the 2-2/3' setting of Drawbar 2. (The factory setting is 74.)

CC# DB2-6 (MIDI Control Change Assign for Drawbar 2-2') [1...31, 33...95, Off]
 Specify the MIDI control change number that will be used to transmit and receive the 2' setting of Drawbar 2. (The factory setting is 75.)

CC# DB2-7 (MIDI Control Change Assign for Drawbar 2-1-3/5') [1...31, 33...95, Off]
 Specify the MIDI control change number that will be used to transmit and receive the 1-3/5' setting of Drawbar 2. (The factory setting is 76.)

CC# DB2-8 (MIDI Control Change Assign for Drawbar 2-1-1/3') [1...31, 33...95, Off]
 Specify the MIDI control change number that will be used to transmit and receive the 1-1/3' setting of Drawbar 2. (The factory setting is 77.)

CC# DB2-9 (MIDI Control Change Assign for Drawbar 2-1') [1...31, 33...95, Off]
 Specify the MIDI control change number that will be used to transmit and receive the 1' setting of Drawbar 2. (The factory setting is 78.)

Appendices

1. How the drawbars work

Drawbar 1 and Drawbar 2 each consist of a set of nine bars.

In Normal mode and Normal Edit mode, these bars have the following functions.

- 16': The pitch one octave below the note you play
- 5-1/3': The pitch a fifth above the note you play
- 8': The pitch of the note you play
- 4': The pitch one octave above the note you play
- 2-2/3': The pitch one octave and a fifth above the note you play
- 2': The pitch two octaves above the note you play
- 1-3/5': The pitch two octaves and a third above the note you play
- 1-1/3': The pitch two octaves and a fifth above the note you play
- 1': The pitch three octaves above the note you play

The white drawbars (8', 4', 2', 1') produce fundamentals. The black drawbars (2-2/3', 1-3/5', 1-1/3') produce pitches that are a fifth or a third above these fundamental pitches. The brown drawbars (16' and 5-1/3') add depth to the tone.

Pulling out the four right bars to a greater extent will produce a harder-toned sound, while pulling out the two left bars to a greater extent will produce a softer tone.

For example when you play middle C, each bar corresponds to the pitches shown in the diagram below. The further a bar is pulled out, the greater its volume will be.

For details on the function of the Drawbar 2 bars (EX Drawbar, EX Percussion) in EX mode and EX Edit mode, refer to the Drawbar 2 illustration (p.9), to the EX Edit mode Group 2 "EX Drawbar Type" parameter, and to the Global mode Group 8 "Type 1 Ex Drawbar 1" through "Type 4 Ex Drawbar 4" parameters.

The CX-3 simulates 79 tone wheels that produce the notes from C2 to F#8, just as on traditional tone wheel organs. This means that if the drawbar settings could cause the pitch to exceed the range of C2 through F#8, the pitch will "wrap around" to the previous octave.

2. MIDI applications

About MIDI

MIDI stands for Musical Instrument Digital Interface, and is a world-wide standard that allows various performance-related data to be exchanged between electronic musical instruments and computers. If a MIDI cable is used to connect MIDI devices, performance data can be exchanged even between electronic musical instruments or computers made by different manufacturers.

Connecting an external MIDI sequencer or computer

If you want to play the keyboard of the CX-3 and record your playing on an external MIDI sequencer/computer (connected via a MIDI interface) while using the CX-3's tone generator to monitor your performance and the playback, or if you want to use the CX-3 as an input keyboard and MIDI tone generator, connect the MIDI OUT and MIDI IN connectors of the CX-3 and the external MIDI sequencer/computer to each other respectively.

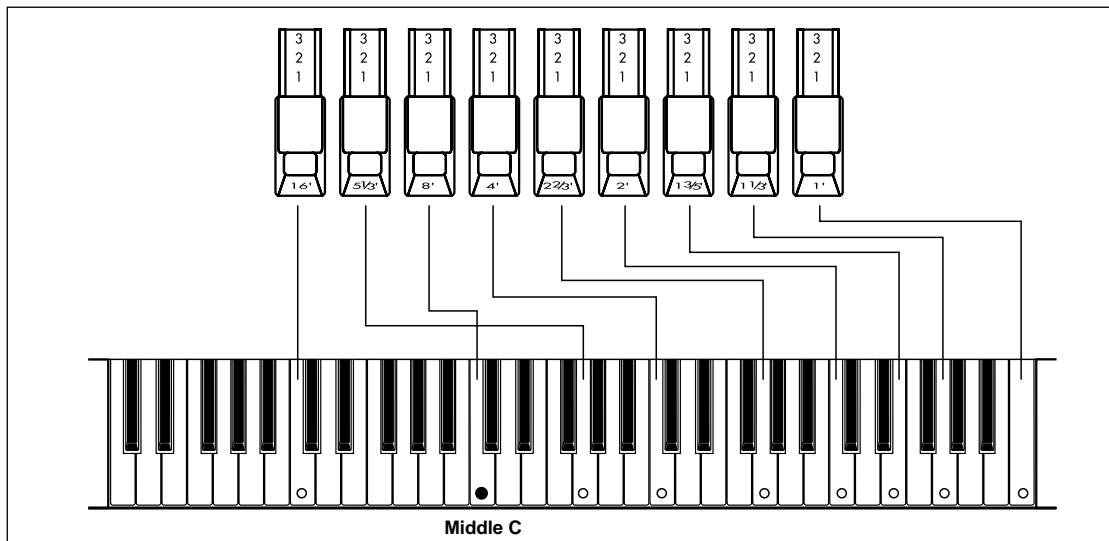
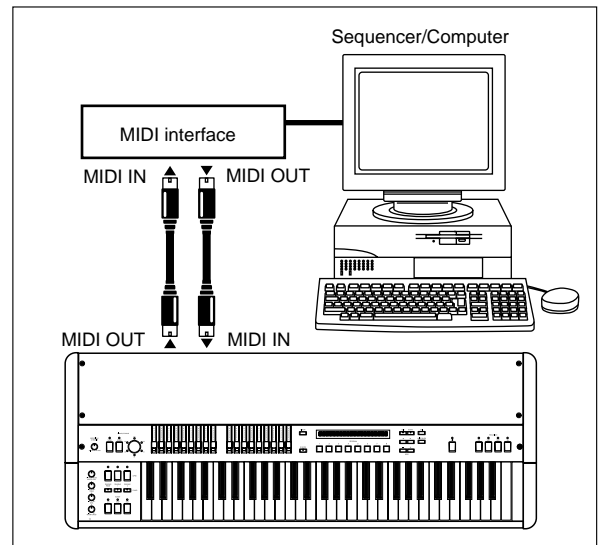



Local Control On setting

If you make connections as shown on the preceding page, you must turn on the Echo Back setting of the external MIDI sequencer or computer (so that the data it receives at MIDI IN will be retransmitted without change from MIDI OUT), and turn **off the Local Control** setting of the CX-3 (to disconnect the keyboard section from the tone generator section).

When you play the keyboard of the CX-3, the data will be sent to the external MIDI sequencer or computer, and will be echoed back to sound the tone generator of the CX-3. In other words by turning the CX-3's **Local Control off**, you can prevent notes from being sounded in duplicate; once from the keyboard and again from the echo-back.

To turn off Local Control, set the Global mode Group 4 "MIDI Local" parameter to Off.

If you are using the CX-3 by itself, you must turn Local Control on. (If this is off, playing the CX-3's keyboard will produce no sound.)



Connecting a MIDI keyboard

If you wish to use the CX-3 in Normal mode, and use a MIDI keyboard connected to the MIDI IN connector to play the CX-3's Lower tone generator, you will need to set the following parameters.

Set the transmit channel of your MIDI keyboard to match the receive channel of the CX-3 (set by the Global mode Group 2 "MIDI Lower Rx Ch" parameter). This allows your MIDI keyboard to be used as the keyboard for the Lower tone generator.

If you also want to connect a sequencer, turn the Global mode Group 4 "Merge Lower Message" parameter On. Channel messages of the channel specified by the "MIDI Lower Rx Ch" will be converted into the channel specified by the "MIDI Lower Tx Ch" parameter, and transmitted.



Using a MIDI tone generator with velocity

The CX-3 is set to transmit note messages (with fixed velocity).

If you are using an external tone generator that is velocity-sensitive, you will need to set the following parameters.

Set the Group 2 "MIDI Upper 2nd Ch" and "MIDI Lower 2nd Ch" parameters to a setting other than Off. With this setting, note messages with velocity will be transmitted on the specified MIDI channel.

However since this would cause two note messages (with and without velocity) to be transmitted, turn the Global mode Group 2 "MIDI Upper Tx Ch" and "MIDI Lower Tx Ch" parameters Off. Now the note messages with fixed velocity will not be transmitted.

As an alternative to the above setting, you can set the "MIDI Upper 2nd Ch" and "MIDI Upper Tx Ch" channel settings and the "MIDI Lower 2nd Ch" and "MIDI Lower Tx Ch" channel settings so that they do not conflict, and set the receive channel of the connected MIDI device so that it can receive note messages with velocity.



The CX-3 will sound even when you press a key lightly. In other words on the CX-3, a note message with fixed velocity will be transmitted when you press a key lightly. However a note message with velocity will not be transmitted until you press the key all the way. This means that if you have made settings to transmit note messages with velocity, there may be cases in which a note message is not transmitted even though the CX-3 has produced sound.

MIDI data dump

The CX-3 can transmit its internal settings to a connected MIDI data file or to another CX-3 as exclusive data.

Transmission



While data is being transmitted, do not touch the CX-3's keys, drawbars, or knobs, and never turn off the power.

There are four types of data dump.

Dump Program: Dump data for one program.

Dump All Programs: Dump all program data.

Dump Global Parameter: Dump global data.

Dump All Programs and Global Parameter: Dump all program data and global data.

Transmitting a data dump

1. **Connect the MIDI OUT connector of the CX-3 to the MIDI IN connector of the device that will receive the data dump.**
2. **Enter Global mode.**
The key LED will light.
3. **While holding down the PROGRAM [7] key, press the [▶] key six times.**

The display will indicate **Dump Program**.

When you select Dump Program, the number of the program to be dumped will be shown in the square brackets [] at the right of the display.

If you wish to **change the program**, use the [-]/[+] keys. The program transmitted here will be a program of the mode that was last selected when you entered Global mode in step 2. If you wish to dump a Normal mode program, select Normal mode before entering Global mode in step 2. Similarly, if you wish to dump an EX mode program, select EX mode before entering Global mode in step 2.



After pressing the PROGRAM [7] key, you can press the [▶] from 6 to 9 times to select the following data to dump.

[▶] key	Screen display	Dumped data
Press 6 times	Dump Program	parameters for 1 program
Press 7 times	Dump All Program	parameters for all programs
Press 8 times	Dump Global	global parameters
Press 9 times	Dump All Prog+Global	all program and global parameters

4. **Press the [WRITE/ENTER] key.**

The display will ask you to confirm the dump operation.

- If you wish to execute the dump, press the **[WRITE/ENTER]** key.

To cancel the dump, press the **[EXIT]** key.

While the data is being transmitted, the display will indicate **TxSysEx Processing...**

The following table shows the size of each data dump and the time it will require.

Data type	Data size	Time required
1 Program Parameter	153 Byte	1 second
All Programs Parameter	18.3 kByte	12 seconds
Global Parameter	300 Byte	1 second
All Prog+Global Parameter	18.6 kByte	12 seconds

- If you save data dumps on a MIDI data filer, do not save multiple dumps together. If you save multiple dumps together, the CX-3 will not have enough time to write the data into memory after receiving it (see the section that follows), and the data will not all be received.

Reception

- While data is being received, do not touch the CX-3's keys, drawbars, or knobs, and never turn off the power.

- When a data dump is received, the CX-3's display will indicate **RxSysEx Processing...** While this is displayed, you must never turn off the power of the CX-3. If you turn off the power, the CX-3 may not function correctly the next time it is turned on again. If this occurs, hold down the Program [2] and [7] keys and turn on the power. However, this will initialize the contents of memory.

While data is being written into memory, MIDI transmission and reception will not occur. If you want the CX-3 to receive multiple data dumps in succession, you must allow a sufficient interval between the transmitted data dumps.

Data type	Writing time
1 Program	approx. 1 second
All Programs	approx. 7 seconds
Global Parameter	approx. 1 second
All Prog+Global Parameter	approx. 7 seconds

Receiving a data dump

- Connect the MIDI IN connector of the CX-3 to the MIDI OUT connector of the device that will transmit the data dump.
- Set the Global channel of the MIDI device to match the global MIDI channel of the CX-3 (set by the Global mode Group 2 "MIDI Global Ch" parameter). If data that was previously transmitted to a MIDI device is being re-transmitted back to the CX-3, set the global MIDI channel of the CX-3 to the setting that was used when transmitting the data.
For details on setting the MIDI channel for transmission, refer to the owner's manual of the device you are using.
- Set the Global mode Group 4 "MIDI Rx Sys Exc" parameter to Ena.
- Send the data dump from the transmitting device. Refer to the owner's manual for your device and transmit the data.

tips If the "MIDI Rx Sys Exc" parameter is set to Ena, data dumps can be received in either Normal mode or EX mode.

- When transmission is finished, the display will indicate **RxSysEx Completed**.

If the display indicates **RxSysEx Error**, turn the power off. Then while holding down the Program [2] and [7] keys, turn the power on again. However, this will initialize the contents of memory.

When the CX-3 receives data for one program, it will enter the same mode (Normal mode or EX mode) in which it was when that program was transmitted. Since the CX-3 will switch to the received mode, you will be in that mode when you press the **[GLOBAL]** key or **[EXIT]** key to exit Global mode after receiving the data dump.

MIDI messages that the CX-3 transmits and receives

[...] indicates hexadecimal notation

MIDI channels

MIDI messages can be received if the MIDI channels of the transmitting and receiving devices match. There are sixteen MIDI channels; 1–16.

MIDI messages are transmitted and received on the global MIDI channel. The global MIDI channel is the basic channel for MIDI transmission and reception, and is set by the Global mode Group 2 "MIDI Global Ch" parameter.

Note-on/off

Note-on [9n, kk, vv]

Note-off [8n, kk, vv]

(n: channel, kk: note number, vv: velocity)

Each time you press or release a note on its keyboard, the CX-3 will transmit a note-on or note-off message.

Very few devices transmit note-off velocity, and the CX-3 does not transmit note-off velocity either.

Program change / Bank select

Changing the program / bank

Program change [Cn, pp]

(n: channel, pp: program number that selects from up to 128 sounds)

- Programs 000–127 in banks A–H correspond to program changes [Cn, 00]–[Cn, 7F].

Bank select MSB (CC#...) [Bn, 00, mm],

Bank select LSB (CC#...) [Bn, 20, bb]

(n: channel, mm: upper byte of bank number, bb: lower byte of bank number)

The program or bank will not change immediately when a bank select message is received. The program and bank will change only when a program change message is subsequently received.

- Program change and bank select messages are transmitted and received on the global MIDI channel. Program changes can be turned on/off by the Global mode Group 4 “MIDI Rx Prg Chng” parameter.



Pitch bend

Pitch bend change [En, bb, mm]

(n: channel, bb: lower byte of value, mm: upper byte of value, together indicating a value of 16384 steps where 8192 [bb, mm=00H, 40H] is the center value)

The CX-3 does not transmit pitch bend changes. When it receives pitch bend changes, a pitch bend effect will be applied. The range in which pitch bend will occur can be specified by the Global mode Group 3 “MIDI P. Bend Range” parameter.



Control change

[Bn, cc, vv]

(n: channel, cc: control change number, vv: value)

- Control changes can be turned on/off by the Global mode Group 4 “MIDI Rx C. Change” parameter.

To silence all notes

All Note Off (CC#123) [Bn, 7B, 00] (value is 00)

When this message is received, all currently-sounding notes will be turned off (as though all keys were released). However, any decay of the notes will remain.

All Sound Off (CC#120) [Bn, 78, 00] (value is 00)

When this message is received, all sound currently being produced will be silenced. While the All Note Off message allows the decay of the notes to remain, All Sound Off causes the sound to be silenced immediately.

However, these messages are intended for use in emergency situations, and are not used during a performance.

To reset all controllers

Reset All Controllers (CC#121) [Bn, 79, 00] (value is 00)

When this message is received, the values of all currently-operating controllers will be reset.



About system exclusive messages

Since system exclusive messages can be used by each manufacturer as they wish, these messages are used mainly to transmit or receive sound data or editing data for parameters that are specific to a particular device. The system exclusive message format for the CX-3 is [F0, 42, 3n, 5B, ff, ... , F7].

- F0: Exclusive status
- 42: Korg ID
- 3n: [n=0-F] Global MIDI channel 1-16
- 5B: CX-3 model ID
- ff: Function ID (type of message)
-
- F7: End of exclusive

Each CX-3 uses the same model ID, so that exclusive data can be exchanged between different CX-3 units.

tips To obtain copy of the “MIDI Implementation” which includes MIDI exclusive format information, please contact your Korg distributor.

Universal system exclusive

Some system exclusive messages have officially defined uses; these are called universal system exclusive messages.

Of the universal system exclusive messages, the CX-3 uses the following Inquiry messages.

Inquiry Message Request [F0, 7E, nn, 06, 01, F7]

Inquiry Message [F0, 7E, nn, 06, 02, (nine bytes), F7]

When an Inquiry Message Request is received, the CX-3 will transmit an Inquiry Message with content that signifies “I am a Korg CX-3, system version ...”

Transmitting sound settings and other data (Data Dump)

Program and global settings can be transmitted as MIDI exclusive messages. The action of transmitting MIDI exclusive messages to an external device is called Data Dump.

By performing a data dump, you can save sound settings or other types of data on an external device, or change the sounds or settings on another CX-3.

The CX-3 uses the following three types of data dump.

- Dump All Program, Dump Global, or Dump All Prog+Global transmits or receives internal memory data. When the CX-3 receives one of these data dumps, the data is written directly into internal memory; it is not necessary for you to perform the Write operation.
- Dump Program transmits or receives data for the program in the edit buffer. When the CX-3 receives one of these data dumps, the data is written into the edit buffer, so if you wish to save it in internal memory you must perform the Write operation. The Write operation can be performed on the CX-3 (refer to p.15 “Writing a program”), or by using a MIDI exclusive Program Write Request.
- In Global mode, a data dump can be performed when the Dump Program, Dump All Program, Dump Global, or Dump All Prog+Global commands are displayed. A data dump will also be transmitted when a dump request is received if the “MIDI Rx Sys Exc” parameter is set to Ena. Data that is received by Dump Program can be written into internal memory by a Write Request.



If notes “hang” (fail to stop)

If a note refuses to stop sounding, press the [EXIT] key.

3. Voice name list

Normal mode programs

Genre	Jazz Perc		Mellow		Rock 1		Gospel		R&B		Jazz		Rock 2		Church	
	1	Pedal1/2	2	Pedal1/2	3	Pedal1/2	4	Pedal1/2	5	Pedal1/2	6	Pedal1/2	7	Pedal1/2	8	Pedal1/2
Bank/No.	Name	Pedal1/2	Name	Pedal1/2	Name	Pedal1/2	Name	Pedal1/2	Name	Pedal1/2	Name	Pedal1/2	Name	Pedal1/2	Name	Pedal1/2
A	Organized	RF/--	Comp	RF/--	Felix'sDakKat	RF/--	BC Gospel 1	RF/--	Classic Soul	RF/--	Joey's LH	RF/--	DS Balls!	RF/--	Quiet Hymn 2	RF/--
B	Brio' J	RF/--	LS Jazz	RF/--	BC LowerComp	RF/--	Preachin'	RF/--	ShoTown	--/--	LS Fats "W"	RF/--	Turkish	RF/WB	Dulciana	RF/--
C	Cat On aMojo	RF/--	Jazz Comp	RF/--	Whyter Shade	RF/--	GPon2Church	RF/--	Huggipz	RF/--	TC Bass Comp	RF/--	SmokelnJapan	--/--	Salcional	RF/--
D	BA PercSplit	--/--	BA Mellow	--/--	Carpet Magic	RF/--	Keepin' On	RF/--	LS DirtyFunk	RF/--	Blueznotes	RF/--	AK ChestBand	RF/--	DM Hymn Pt2	RF/--
E	GP NicePerc	RF/--	Barfly	RF/--	Nice Chords	RF/--	LSGospelFunk	RF/--	BC Schnoz	RF/--	Jazzy Ballad	RF/--	Mr. Nice :-)	RF/--	French Horn	RF/--
F	Go McJimmy	RF/--	Joey' Jazz	RF/--	Gimme Some	RF/--	BC Gospel.2	RF/--	Wat's Up?	RF/--	Slow Groove	RF/--	Deep Hush	RF/--	Oboe Horn	RF/--
G	BC Best Solo	RF/--	AK Smooth"J"	RF/--	AK OnionBook	RF/--	TC SoulfuISP	RF/--	Smoothie	RF/--	Perc Combo	--/--	BC Rock Solo	RF/--	Quiet Hymn 1	RF/--
H	GP MintJewel	RF/--	BA THE Sound	--/--	Voxinental	--/--	BC Best Full	RF/--	Memphis Soul	RF/--	TC Celeste	RF/--	Whirly Perc	RF/--	DM Hymn Pt1	RF/--

EX mode programs

Genre	Standard Solo		Pipe Organ		Attack		EX Mellow		Bright		Clean/Perc		Combo		EFX	
	1	Pedal1/2	2	Pedal1/2	3	Pedal1/2	4	Pedal1/2	5	Pedal1/2	6	Pedal1/2	7	Pedal1/2	8	Pedal1/2
Bank/No.	Name	Pedal1/2	Name	Pedal1/2	Name	Pedal1/2	Name	Pedal1/2	Name	Pedal1/2	Name	Pedal1/2	Name	Pedal1/2	Name	Pedal1/2
A	I Gota EX!	RF/--	Pipe Organ 1	--/--	EX Perky 2	RF/--	EX Gentle 1	RF/--	Mixture 1	RF/--	Clean 1	RF/--	Combo 1	--/--	Maely Echo	RF/--
B	TC EX-Glassy	RF/--	Pipe Organ 2	--/--	EX Perky 3	RF/--	Clean 5	RF/--	Mixture 2	RF/--	Clean 2	--/--	Combo 2	--/--	Echo Bells	RF/--
C	EX Rock Perc	RF/--	Pipe Organ 3	--/--	Attack 1	RF/--	Clean 6	RF/--	Mixture 3	RF/--	Clean 3	RF/--	Combo 3	--/--	Cluster Echo	RF/--
D	B Leakn	RF/--	Full Pipes	--/--	Attack 2	RF/--	EX Sweet 2	RF/--	Mixture 4	RF/--	Clean 4	--/--	Combo 4	--/--	Cricket	RF/--
E	Attack Fat	RF/--	Mix Bright 2	--/--	Attack 3	RF/--	EX Gentle 2	RF/--	EX All	RF/--	Percussion 1	RF/--	Combo 5	--/--	Space Organ	RF/--
F	EX Mr. Nice	RF/--	EX Church	RF/--	Metal 1	RF/--	EX Sweet 1	RF/--	Bright 1	RF/--	Percussion 2	RF/--	Combo 6	RF/--	Only EX	RF/--
G	TC EX-Fusion	RF/--	EX Chapel	RF/--	Metal 2	RF/--	Comp+Perc	RF/--	Bright 2	RF/--	Percussion 3	RF/--	Callope Lead	RF/--	EX CatchCold	RF/--
H	EX Perky 1	RF/--	EX Hymnal	RF/--	EX Otones	RF/--	Mix Bright 1	RF/--	Gen-EX!	RF/--	EX Bass	RF/--	Toy Organ	RF/--	Low Synth	--/--

Pedal1/2... Assignable Pedal/SW 1 / Assignable Pedal/SW 2 settings.

RF: Rotary Fast control

WB: Wheel Brake control

--: off

Demo song names

- 1 Y's Groovin'
- 2 Katana
- 3 Church Hymn
- 4 TC Kool Blues
- 5 GP Jazz Waltz
- 6 BC CX Preclude
- 7 GP Gospel
- 8 Samba de Rit
- 9 Mama takes me

All songs copyright by KORG Inc.

* Special thanks for preset voicing and demo songs

- BA: Brian Auger
- GP: Greg Phillinganes
- AK: Al Kooper
- BC: Bill Champlin
- TC: Tom Coster
- LS: Lonnie Smith
- DM: Don Muro
- DS: Derek Sherinian and more

4. Troubleshooting

Power does not turn on

- Is the power cable connected to an AC outlet?
Check the connection. (see p.6)
- Is the power switch turned ON?
Make sure that the power switch is ON.

No sound

- Are the other devices or headphones connected correctly?
Check the connections. (see p.6)
- Is the power of your amp or mixer turned on?
- Is the [MASTER LEVEL] knob raised?
- Is the Global mode Group 4 "MIDI Local" parameter turned On?
Check the setting of this parameter.
- Are the bars of Drawbar 1 or 2 pulled out?
Pull out some of the bars.

Moving the bars does not affect the sound

- Is the setting of the DRAWBAR SELECT section correct?
If you wish to play using the bars, select UPPER [DRAWBAR 1] or UPPER [DRAWBAR 2]. (see p.8)

Percussion is not applied

- Is the setting of the DRAWBAR SELECT section correct?
If you wish to use the keys of the percussion section, select UPPER [DRAWBAR 2] in the DRAWBAR SELECT section. (see p.11)
- Is the Normal Edit mode "DB Preset's Perc" parameter set to Ena?
Check the setting of this parameter. (see p.11)
- Are the percussion-related parameters set correctly?
The percussion "soft" value is determined by adding the Normal Edit mode "Percussion Normal Level" parameter value to the "Percussion Soft Offset" parameter value. If the sum is less than 0, no percussion will be heard. (see p.18)

Rotary speaker effect is not applied

- Is the amp selection correct?
Select either Type 1 or Type 2 for the Normal Edit mode or EX Edit mode Group 4 "Amp Type" parameter. If you select Pre Amp, the rotary speaker cannot be used.
..... (see p.19)

The CX-3 does not respond to MIDI data from an external device

- Is the MIDI cable connected correctly?
Check the connection. (see p.27)
- Is the global MIDI channel set correctly?
Check the setting.

The CX-3 does not respond correctly to MIDI data from an external device

- If you are receiving MIDI exclusive messages, is the "MIDI Rx Sys Exc" parameter set to Ena?
Check the setting of this parameter.
- Does the CX-3 support the message that is being transmitted?

Operating a pedal switch or expression pedal connected to the rear panel does not produce the intended operation

- Have you selected Pedal 1 or Pedal 2 for the Global mode Group 1 "Prog Up Ctrl" or "Prog Down Ctrl" parameters?
It is possible to assign multiple functions to a pedal switch or expression pedal. However if a pedal switch etc. is assigned to the Global mode Group 1 "Prog Up Ctrl" or "Prog Down Ctrl" parameter, the Global setting will take priority, and the setting of Normal Edit mode or EX Edit mode will be ignored. Check the settings of these parameters.

Unexpected things occur when the CX-3 is connected to an external MIDI device

- Is there a CC# conflict?
The CX-3 can transmit most of the operations of its front panel keys and drawbars etc. as control change numbers. This means that with the factory settings, some of the control change numbers will conflict with standard MIDI devices, and when the CX-3 is connected via MIDI to other devices, these control changes will coincide with different functions on the other device, producing unexpected results. Check the Global mode Group 6 and 7 CC# parameters, and turn off unneeded parameters or change their CC#.

5. Specifications and options

Tone generator section

Tone generator: Tone wheel organ modeling tone generator

Polyphony: Full keyboard polyphony

Modes

Normal mode, EX mode, Normal Edit mode, EX Edit mode, Global mode

Effect section

Vibrato/chorus, rotary speaker, overdrive, reverb

Number of programs

Normal mode: 64 (A-1-H-8)

EX mode: 64 (A-1-H-8)

Keyboard

61 note

Controllers

DRAWBAR SELECT section:

[DRAWBAR 1] key, [DRAWBAR 2] key, [PRESET DRAWBAR] key (these are for the Upper tone generator)

[DRAWBAR 1] key, [DRAWBAR 2] key, [PRESET DRAWBAR] key (these are for the Lower tone generator)

DRAWBAR section: Drawbar 1, Drawbar 2

PERCUSSION section: [ON] key, [SOFT] key, [FAST] key, [3rd] key

ROTARY section: [ON] key, [STOP] key, [FAST] key

VIBRATO CHORUS section: [UPPER] key, [LOWER] key, [VIBRATO/CHORUS] knob

AMP section: [MASTER LEVEL] knob, [TREBLE] knob, [BASS] knob, [REVERB OFFSET] knob

Other: [EXPRESSION/OVERDRIVE] knob, [DISPLAY] key, [EX MODE] key, [EDIT] key, [GLOBAL] key, [WRITE/ENTER] key, [EXIT] key, PROGRAM [1]-[8] keys, [√] [▶] keys, [+]/[-] keys, [SPLIT] key

Outputs

OUTPUT L, R jacks:

Maximum output level +17.5 [dBu]

Load impedance 10 [k-ohm] or more

PHONES jack:

Maximum output level 50 mw @ 32 ohms / channel

Control inputs

EXPRESSION PEDAL jack

ASSIGNABLE PEDAL/SW 1, 2 jacks

Other

MIDI IN connector, MIDI OUT connector, MIDI THRU controller, AC power supply connector, Power switch

Dimensions (W x D x H)

1,082 x 403 x 148 (mm)

Weight

17 kg

Power consumption

14 W

Included items

Power cable, Expression pedal

Options

XVP-10 EXP/VOL pedal, EXP-2 Foot Controller, PS-1 Pedal Switch, MIDI cable

*Appearance and specifications of this product may change without notice. (As of September, 2000.)

Operation of included Expression pedal

Fortissimo function

This allows you to selectively emphasise parts of your performance.

As shown in the diagram, the pedal angle is 30° when fully raised. The pedal will rest at any point you take your foot off from fully raised to standard position.

If you depress the pedal further from standard position, it will return to standard position when you take your foot off.

Also, by adjusting the screw on the bottom, you may adjust the spring return range from 0°-10°.

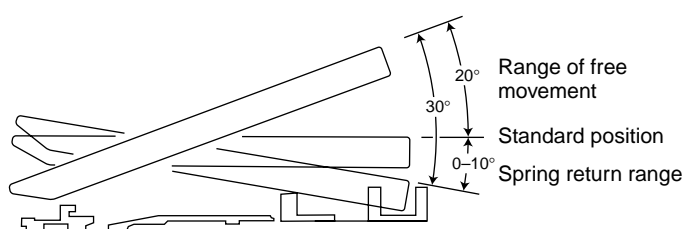

Selectable pedal angle

As shown below, you may change the pedal angle to fit your plying position.

To select pedal angle

1. Loosen hook screw with a screwdriver.
2. Move the pedal body to the position in the illustration.
3. Retighten the hook screw.

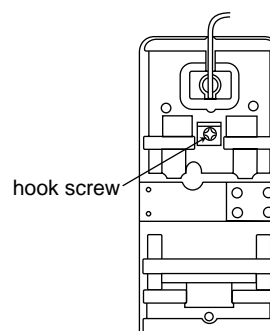
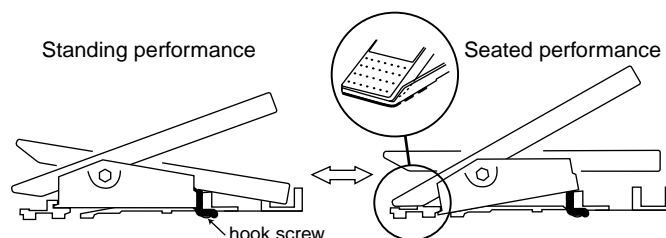

Cable storage

Store the cable as shown.

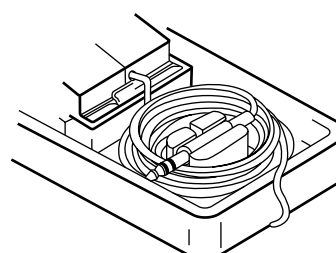

6. MIDI implementation chart

[COMBO ORGAN]
CX-3

Date : 2000. 06. 15
Ver. 1.0

Function		Transmitted	Recognized	Remarks
Basic Channel	Default	1 – 16	1 – 16	Memorized
	Changed	1 – 16	1 – 16	
Mode	Memorized	X	3	
	Messages	X	X	
	Altered	*****		
Note Number	True Voice	36 – 96	36 – 96	
		*****	36 – 96	
Velocity	Note On	1 – 127	X	
	Note Off	0 – 127	X	
Aftertouch	Polyphonic (Key)	X	X	
	Monophonic (Channel)	X	X	
Pitch Bend		X	O	
Control Change	16 – 24 *2	O	O	Drawbar 1 *1
	70 – 78 *2	O	O	Drawbar 2 *1
	81, 82, 83 *2	O	O	Rotary ON FAST STOP *1
	84, 85, 86 *2	O	O	V/C Select Upper Lower *1
	87, 88, 94, 95 *2	O	O	Percussion ON SOFT FAST 3rd *1
	79 *2	O	O	Upper Drawbar Select *1
	80 *2	O	O	Lower Drawbar Select *1
	11 *2	O	O	Expression *1
	64 *2	O	O	Hold *1
	93 *2	O	O	Wheel Brake *1
	92 *2	O	O	AMP Gain *1
91 *2	O	O	Reverb Level *1	
Program Change	Variable Range	O 0 – 127	O 0 – 127	*3
		*****	0 – 127	
System Exclusive		O	O	*4, *5
System Common	Song Position	X	X	
	Song Select	X	X	
	Tune	X	X	
System Real Time	Clock	X	X	
	Command	X	X	
Aux Messages	Local On/Off	X	X	
	All Notes Off	X	O	
	Active Sense	X	X	
	Reset	X	X	
<p>Notes *1: Transmitted and received when Global MIDI Tx C.Chng and MIDI Rx C.Chng are set to "ENA" are respectively ENA. *2: Factory setting. User editable. *3: Received when Global mode MIDI Rx PrgChng parameter is set to "ENA". *4: Received when Global mode MIDI Rx Sys Exc parameter is set to "ENA". *5: In addition to Korg exclusive messages, Inquiry and Master Volume are supported.</p>				

Mode 1: OMNI ON, POLY
Mode 3: OMNI OFF, POLY

Mode 2: OMNI ON, MONO
Mode 4: OMNI OFF, MONO

O : Yes
X : No

Index

- C**
- Connections 6
 - Computer 27
 - Expression pedal 6
 - MIDI connections 6
 - MIDI data filer 28
 - MIDI keyboard 28
 - MIDI sequencer 27
 - MIDI tone generator with velocity 28
 - Pedal switch 6
 - Copy
 - Copying a program 16
 - Copying drawbar parameters 14
- D**
- Data Dump 26, 28
 - Demo songs
 - Demo song name list 31
 - Listening to the demo songs 13
 - Display
 - Drawbar levels 7
 - Icons 7
 - In EX mode 7
 - In Normal mode 7
 - Drawbar
 - Copying drawbar parameters 14
 - Drawbar 1 2, 9
 - Drawbar 2
 - EX Drawbar 2, 9
 - EX Percussion 2, 9
 - Drawbar parameters (Group 2) 17
 - DRAWBAR section 2
 - DRAWBAR SELECT section 3
 - Editing the drawbar parameters 14
 - How the drawbars work 27
- M**
- MIDI 27
 - About MIDI 27
 - Data dump 26, 28
 - Local Control On settings 28
 - MIDI Channel settings (Group 2) 23
 - MIDI Control Channel settings (Group 5, 6) 24, 25
 - MIDI Filter settings (Group 4) 23
 - MIDI implementation chart 34
 - MIDI messages
 - About system exclusive messages 30
 - Bank select 29
 - Control change 30
 - If notes "hang" (fail to stop) 30
 - MIDI channels 29
 - Note-on/off 29
 - Pitch bend 30
 - Program change 29
- O**
- Options 33
 - Overdrive 13
- P**
- Pedal
 - Expression pedal
 - Adjusting the minimum level (Exp Minimum Level) 22
 - Adjusting the sensitivity (Exp Pd 1 Calibration) 26
 - Assigning a function 20, 22
 - Assigning a MIDI Control Change No. 25
 - Pedal switch
 - Assigning a function 22
 - Setting the polarity (Pedal 1/2 Sw Polarity) 23
 - Percussion 11
 - Program
 - About programs 8
 - Changing the program name (Rename) 21
 - Changing the program name when you save 16
 - Copying a program 16
 - Program name list 31
 - Returning a program to the factory settings 16
 - Selecting a program 8
 - Swap Program 25
- R**
- Reverb 13, 19
 - Rotary speaker 12, 25
- S**
- Shortcut 7
 - Specifications 33
 - Split
 - Playing a split 11
- V**
- Vibrato and chorus 12
- W**
- Writing a program 15
 - Writing global settings 16

NOTICE

KORG products are manufactured under strict specifications and voltages required by each county. There products are warranted by the KORG distributor only in each country. Any KORG product not sold with a warranty card or carrying a serial number disqualifies the product sold from the manufacture's/distributor's warranty and liability. This requirement is for your own protection and safety.

KORG **KORG INC.**

15-12, Shimotakaido 1-chome, Suginami-ku, Tokyo, Japan