

# ME

MUSIC WORKSTATION/SAMPLER

## Operation Guide



Enhanced Definition  
Synthesis





# KORG

# IMPORTANT SAFETY INSTRUCTIONS

- Read these instructions.
- Keep these instructions.
- Heed all warnings.
- Follow all instructions.
- Do not use this apparatus near water.
- Mains powered apparatus shall not be exposed to dripping or splashing and that no objects filled with liquids, such as vases, shall be placed on the apparatus.
- Clean only with dry cloth.
- Do not block any ventilation openings. Install in accordance with the manufacturer's instructions.
- Do not install near any heat sources such as radiators, heat registers, stoves, or other apparatus (including amplifiers) that produce heat.
- Do not defeat the safety purpose of the polarized or grounding-type plug. A polarized plug has two blades with one wider than the other. A grounding type plug has two blades and a third grounding prong. The wide blade or the third prong are provided for your safety. If the provided plug does not fit into your outlet, consult an electrician for replacement of the obsolete outlet. (for USA and Canada)
- Protect the power cord from being walked on or pinched particularly at plugs, convenience receptacles, and the point where they exit from the apparatus.
- Only use attachments/accessories specified by the manufacturer.
- Unplug this apparatus during lightning storms or when unused for long periods of time.
- Turning off the power switch does not completely isolate this product from the power line so remove the plug from the socket if not using it for extended periods of time.
- Install this product near the wall socket and keep the power plug easily accessible.
- WARNING—This apparatus shall be connected to a mains socket outlet with a protective earthing connection.
- Refer all servicing to qualified service personnel. Servicing is required when the apparatus has been damaged in any way, such as power-supply cord or plug is damaged, liquid has been spilled or objects have fallen into the apparatus, the apparatus has been exposed to rain or moisture, does not operate normally, or has been dropped.
- Do not install this equipment on the far position from wall outlet and/or convenience receptacle.
- Do not install this equipment in a confined space such as a box for the conveyance or similar unit.
- Battery shall not be exposed to excessive heat such as sunshine, fire or the like.
- Excessive sound pressure from earphones and headphones can cause hearing loss.
- Use only with the cart, stand, tripod, bracket, or table specified by the manufacturer, or sold with the apparatus. When a cart is used, use caution when moving the cart/apparatus combination to avoid injury from tip-over.



**WARNING:**  
TO REDUCE THE RISK OF FIRE OR ELECTRIC SHOCK DO NOT EXPOSE THIS PRODUCT TO RAIN OR MOISTURE.

	<b>CAUTION</b> RISK OF ELECTRIC SHOCK DO NOT OPEN	
<b>AVERTISSEMENT:</b> RISQUE DE CHOC ÉLECTRIQUE—NE PAS OUVRIR.		
<b>注意</b> 感電の恐れあり、キャビネットをあけるな		

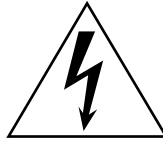

The lightning flash with arrowhead symbol within an equilateral triangle, is intended to alert the user to the presence of uninsulated “dangerous voltage” within the product’s enclosure that may be of sufficient magnitude to constitute a risk of electric shock to persons.



The exclamation point within an equilateral triangle is intended to alert the user to the presence of important operating and maintenance (servicing) instructions in the literature accompanying the product.

## CAUTION

Danger of explosion if battery is incorrectly replaced. Replace only with the same or equivalent type.

### THE FCC REGULATION WARNING (for USA)

This equipment has been tested and found to comply with the limits for a Class B digital device, pursuant to Part 15 of the FCC Rules. These limits are designed to provide reasonable protection against harmful interference in a residential installation. This equipment generates, uses, and can radiate radio frequency energy and, if not installed and used in accordance with the instructions, may cause harmful interference to radio communications. However, there is no guarantee that interference will not occur in a particular installation. If this equipment does cause harmful interference to radio or television reception, which can be determined by turning the equipment off and on, the user is encouraged to try to correct the interference by one or more of the following measures:

- Reorient or relocate the receiving antenna.
- Increase the separation between the equipment and receiver.
- Connect the equipment into an outlet on a circuit different from that to which the receiver is connected.
- Consult the dealer or an experienced radio/TV technician for help.

Unauthorized changes or modification to this system can void the user’s authority to operate this equipment.

### Notice regarding disposal (for EU)



If this “crossed-out wheeled bin” symbol is shown on the product or in the operating manual, you must dispose of the product in an appropriate way. Do not dispose of this product along with your household trash. By disposing of this product correctly, you can avoid environmental harm or health risk. The correct method of disposal will depend on your locality, so please contact the appropriate local authorities for details.

## Handling of this product

This product contains precision components, and may malfunction if you fail to observe the following precautions.

- Do not subject this product to vibration or impact.  
Doing so may damage internal components and cause malfunctions.
- Do not use or store this product in locations of extremely low or high temperatures, such as outdoors in winter or in direct sunlight in summer. Avoid moving this product between locations of dramatically different temperatures.  
If a temperature difference occurs, water droplets may form inside the product. Continuing to use the product in this state may cause malfunctions, so you should wait several hours before using the product.
- Do not use or store this product in locations of extremely high humidity.
- Do not use or store this product in excessively dusty or smoky locations.

## Regarding the display

This M3's display is a precision device created using extremely high technology, and careful attention has been paid to its product quality. Although you may notice some of the issues listed below, please be aware that these are due to the characteristics of LCD displays, and are not malfunctions.

- There may be pixels in the display that are always dark (unlit) or always bright (lit).
- Depending on the displayed content, the brightness of the display may appear uneven.
- Depending on the displayed content, horizontal stripes of shading may be visible.
- Depending on the displayed content, flickering or moire patterns may be visible.

## Data handling

Incorrect operation or malfunction may cause the contents of memory to be lost, so we recommend that you save important data on a CD or other media. Please be aware that Korg will accept no responsibility for any damages which may result from loss of data.

### COPYRIGHT WARNING

This professional device is intended only for use with works for which you yourself own the copyright, for which you have received permission from the copyright holder to publicly perform, record, broadcast, sell, and duplicate, or in connection with activities which constitute "fair use" under copyright law. If you are not the copyright holder, have not received permission from the copyright holder, or have not engaged in fair use of the works, you may be violating copyright law, and may be liable for damages and penalties. If you are unsure about your rights to a work, please consult a copyright attorney. **KORG TAKES NO RESPONSIBILITY FOR ANY INFRINGEMENT COMMITTED THROUGH USE OF KORG PRODUCTS.**

- 
- \* KARMA<sup>®</sup> (Kay Algorithmic Realtime Music Architecture) Technology has been licensed from Stephen Kay, and is protected by U.S. Patents 5,486,647, 5,521,327, 6,084,171, 6,087,578, 6,103,964, 6,121,532, 6,121,533, 6,326,538, 6,639,141, and 7,169,997. Other patents pending.
  - \* KARMA<sup>®</sup> and the KARMA Logo are registered trademarks, and Generated Effect<sup>™</sup> (GE), Melodic Repeat<sup>™</sup>, Direct Index<sup>™</sup>, Manual Advance<sup>™</sup>, SmartScan<sup>™</sup>, Freeze Randomize<sup>™</sup>, Random Capture<sup>™</sup>, Random FF/REW<sup>™</sup> and Scene Matrix<sup>™</sup> are trademarks of Stephen Kay, Karma Lab LLC. This manual copyright © 1994-2004 by KORG Inc. and Stephen Kay. All rights reserved.
  - \* Screen shots from the KARMA software that appear throughout this guide are © 1994-2004 by Stephen Kay, Karma Lab LLC. Used by permission. All rights reserved.
  - \* KARMA Technology can be located on the internet at: [www.karma-lab.com](http://www.karma-lab.com).
  - \* This product uses the T-Kernel source code in compliance with the T-License of the T-Engine forum ([www.t-engine.org](http://www.t-engine.org)).
  - \* Apple, Mac, FireWire and Audio Units are trademarks of Apple Computer, Inc., registered in the US. and other countries.
  - \* Windows XP is a registered trademark of Microsoft Corporation in the U.S. and other countries.
  - \* VST is a trademark of Steinberg Media Technologies GmbH.
  - \* RTAS is a registered trademark of Avid Technology, Inc., or its subsidiaries or divisions.
  - \* All other product and company names are trademarks or registered trademarks of their respective holders.

Thank you for purchasing the Korg M3 Music Workstation/Sampler. To help you get the most out of your new instrument, please read this manual carefully.

## About this manual

### The owner's manuals and how to use them

The manuals and how to use them

The M3 comes with the following operation manuals.

- M3 Operation Guide
- M3 Parameter Guide (PDF)
- M3 Voice Name List (PDF)
- Keyboard Assembly Operation Guide (included with the M3-61/73/88)  
Using the M3-M Brackets (included only with M3-M sold by itself)
- M3 Editor/Plug-In Editor Operation Manual (PDF)
- EXB-RADIAS for M3 Operation Manual (PDF)

The above PDF files are located in the "MANUALS" folder of the included CD-ROM. Driver operating manuals such as for the KORG USB-MIDI driver are located in the same folder as the drivers.

#### M3 Operation Guide

Please read this first. It explains the names and functions of each part of the M3, how to make connections, basic operation, an overview of each mode, how to edit sounds, how to record on the sequencer, and how to sample. This guide also explains the KARMA function, effects, drum track, and drum kits.

This also explains items you should check before suspecting a malfunction, error messages, specifications, and installation of EXB options.

#### M3 Parameter Guide

This explains details of the M3's parameters, organized by mode and page. Refer to this guide when you want to learn more about an unfamiliar parameter.

#### M3 Voice Name List

This lists the names of the multisamples, drum samples, the factory-set combinations, programs, drum kits, and KARMA settings. Refer to this list when you want to learn about this preloaded content.

#### Keyboard Assembly Operation Manual

##### Using the M3-M Brackets

"Keyboard Assembly Manual" is included with the M3-61/73/88. It explains how to tilt the M3-M (sound generator module) upward from the keyboard assembly, and how to remove or attach the M3-M.

"Using the M3-M Brackets" is included only with the M3-M sold by itself. It explains how to attach the brackets to the M3-M so that it can be placed on a table or other surface at a comfortable angle.

##### M3 Editor/Plug-In Editor Manual

This explains setup and use of M3 Editor and M3 Plug-In Editor.

#### EXB-RADIAS for M3 Manual

This explains details of the parameters available when the optional EXB-RADIAS installed in the M3, organized by mode and page.

## Conventions in this manual

### References to the M3

The M3 is available as several models: the 88-key M3-88, the 73-key M3-73, the 61-key M3-61, and the sound module by itself as the M3-M. References in these manuals to "the M3" refer to all of these models collectively.

### Abbreviations for the manuals: OG, PG

In the documentation, references to the manuals are abbreviated as follows.

**OG:** Operation Guide

**PG:** Parameter Guide

### Procedure steps 1. 2. 3. ...

These indicate the steps of a procedure.

### Symbols , , Note, Tips

These symbols respectively indicate a caution, a MIDI-related explanation, a supplementary note, or a tip.

### Example screen displays

The parameter values shown in the example screens of this manual are only for explanatory purposes, and may not necessarily match the values that appear in the Display of your instrument.

### MIDI-related explanations

CC# is an abbreviation for Control Change Number.

In explanations of MIDI messages, numbers in square brackets [ ] always indicate hexadecimal numbers.

### What is REMs ?

**REMS** (Resonant structure and Electronic circuit Modeling System) is Korg's proprietary technology for digitally recreating the numerous factors that produce and influence a sound, ranging from the sound-production mechanisms of acoustic instruments and electric/electronic musical instruments, to the resonances of an instrument body or speaker cabinet, the sound field in which the instrument is played, the propagation route of the sound, the electrical and acoustic response of mics and speakers, and the changes produced by vacuum tubes and transistors.



---

# Table of Contents

Handling of this product .....	iii
Regarding the display .....	iii
Data handling .....	iii
COPYRIGHT WARNING .....	iii
About this manual .....	iv

## Quick Start .....

**1**

Setup .....	1
Playing Programs and Combinations .....	2
Listening to the demo songs .....	5

## Introduction to the M3 .....

**7**

### Main Features .....

**7**

#### Front and rear panels .....

**9**

Front panel .....	9
Rear panel/Bottom panel .....	15
Objects in the display .....	17

#### Basic Information .....

**20**

About the M3's modes .....	20
Basic operations .....	22

## Setup .....

**25**

### Turning the power on/off .....

**25**

Connecting the AC cable .....	25
Turning the power on .....	25
Turning the power off .....	25

### Connections .....

**26**

Connecting audio equipment .....	27
Connecting a damper pedal, foot switch, or foot pedal .....	29
Connecting a computer .....	30
Connecting MIDI devices .....	33
Connecting a USB device (HDD, CD-R/RW, etc.) .....	33
Installing the software .....	34

## Playing and editing Programs ..

**37**

### Playing Programs .....

**37**

Selecting Programs .....	37
Performing with KARMA and the Drum Track .....	40
Using Controllers .....	41
Controller settings for the program .....	46

### Easy Program editing .....

**47**

Simple editing using the sliders and switches .....	47
Using COMPARE .....	49
Saving your edits .....	50

### Detailed Editing with Programs .....

**51**

Overview of editing pages .....	51
Basic oscillator settings .....	51
Using LFOs and Envelopes (EGs) .....	54
Using Alternate Modulation (AMS) and the AMS Mixers .....	55
Controlling Pitch .....	56
Using Filters .....	57
Using the Amp section .....	60
X-Y control settings .....	62
KARMA settings .....	63
Drum Track settings .....	63
Effects .....	63
Automatically importing a Program into Sequence mode .....	64

## Playing and editing Combinations .....

**65**

### Playing combinations .....

**65**

Selecting Combinations .....	65
Performing with KARMA and the Drum Track .....	67
Using controllers to modify the sound .....	67

### Easy Combination editing .....

**68**

Changing the programs within the Combination .....	68
Adjusting the mix .....	68
Simple editing using the Sliders and Switches .....	69
Saving a Combination you've edited .....	69

### Detailed Editing with Combinations .....

**70**

Overview of editing pages .....	70
A suggested approach for editing .....	71
Layers, Splits, and Velocity Switches .....	71
MIDI settings .....	73
Altering Programs to fit within a Combination .....	74
Effects .....	75
Automatically importing a Combination into Sequencer mode .....	75

<b>Creating songs (Sequencer mode) . . . . .</b>	<b>77</b>
<b>Overview . . . . .</b>	<b>77</b>
About the M3's Sequencer . . . . .	77
Sequencer mode structure . . . . .	77
<b>Playing Songs . . . . .</b>	<b>80</b>
Playback . . . . .	80
Control using the sliders and switches . . . . .	82
<b>MIDI recording . . . . .</b>	<b>83</b>
Preparations for recording . . . . .	83
Recording MIDI in real-time . . . . .	85
Step recording . . . . .	88
Recording variation . . . . .	89
Recording patterns . . . . .	93
<b>Song editing . . . . .</b>	<b>95</b>
<b>Using RPPR (Realtime Pattern Play/Record). 97</b>	<b>97</b>
Creating RPPR data . . . . .	97
RPPR playback . . . . .	98
Recording an RPPR performance . . . . .	98
<b>Sampling in Sequencer mode. . . . .</b>	<b>100</b>
<b>Creating and playing a Cue List . . . . .</b>	<b>101</b>
Creating a cue list . . . . .	101
Converting a cue list into a song . . . . .	102
<b>Saving your song . . . . .</b>	<b>103</b>
<b>Cautions and other functions in Sequencer mode . . . . .</b>	<b>104</b>
M3 sequencer file formats . . . . .	104
The Compare function . . . . .	104
Memory Protect. . . . .	105
About MIDI . . . . .	105
<b>Sampling (Open Sampling System) . . . . .</b>	<b>107</b>
<b>Sampling Overview . . . . .</b>	<b>107</b>
About sampling . . . . .	107
Compare . . . . .	109
<b>Sampling and editing in Sampling mode . .</b>	<b>110</b>
Creating multisample indexes and sampling – P0: Recording . . . . .	110
Basic sampling procedure . . . . .	112
Loop Edit – P2: Loop Edit . . . . .	116
Sample (waveform data) editing – P1: Sample Edit . . . . .	118
Multisample editing – P3: Multisample Edit . . . . .	119
Ripping – P5: Audio CD . . . . .	120
Converting a multisample to a program . . . . .	120
Using a sample in a drum kit . . . . .	121
Saving multisamples and samples . . . . .	121
<b>Sampling in Program, Combination, and Sequencer modes . . . . .</b>	<b>122</b>
Resampling a phrase generated by the KARMA function . . . . .	122
Sampling only an external guitar sound while listening to phrases generated by the KARMA function . . . . .	123
Sampling a mix of the phrases generated by the KARMA function together with an external guitar sound . . . . .	125
In-Track Sampling . . . . .	126
Resampling a song to create a WAVE file. . . . .	127
<b>Settings for the entire M3 (Global mode) . . . . .</b>	<b>129</b>
<b>How Global mode is structured . . . . .</b>	<b>129</b>
<b>Global settings . . . . .</b>	<b>129</b>
Basic setup . . . . .	129
System preference . . . . .	130
Audio input settings . . . . .	131
MIDI Basic/Routing . . . . .	131
External control. . . . .	131
Pedal and other controller settings . . . . .	132
Assigning MIDI CC#s to KARMA, X–Y, and Pad controllers. . . . .	133
Creating user scales. . . . .	133
Setting Category Names . . . . .	134
<b>Using Drum Kits . . . . .</b>	<b>135</b>
Drum Kit Overview. . . . .	135
Editing Drum Kits . . . . .	136
Saving Drum Kits . . . . .	138
<b>Loading &amp; saving data, and creating CDs . . . . .</b>	<b>139</b>
<b>Saving data . . . . .</b>	<b>139</b>
Types of data that can be saved . . . . .	139
Writing to internal memory . . . . .	140
Saving to media (Media–Save) . . . . .	142
Using the M3 as a data filer. . . . .	144
<b>Loading data . . . . .</b>	<b>145</b>
Data that can be loaded. . . . .	145
Loading data from media (Media–Load) . . . . .	145
<b>Media utility . . . . .</b>	<b>148</b>
File copying, deleting, and formatting (Media– Utility). . . . .	148
<b>Creating audio CDs . . . . .</b>	<b>150</b>
Creating and playing audio CDs (Media– Make Audio CD, Play Audio CD). . . . .	150
Creating audio CDs . . . . .	150
Viewing information about media – Media Info . . . . .	152

---

## Using Effects . . . . . 153

### An overview of the M3's effects . . . . . 153

- Effect types . . . . . 153
- Effect I/O . . . . . 153
- Effects in each mode . . . . . 154

### Routing effect settings . . . . . 155

- Program Effects settings . . . . . 155
- Using effects in Combinations and Songs . . . . . 157
- Effect settings in Sampling mode . . . . . 158
- Effect settings for the audio inputs . . . . . 159

### Dynamic modulation, MIDI/Tempo Sync, and Common FX LFO . . . . . 161

- Dynamic modulation (Dmod) . . . . . 161
- Common FX LFO . . . . . 162

## Using KARMA . . . . . 163

### Overview . . . . . 163

- What is KARMA? . . . . . 163
- The structure of the KARMA function . . . . . 163

### Performing with KARMA . . . . . 167

- Performing with KARMA in Program mode . . . . . 167
- Performing with the KARMA function in Combination mode . . . . . 169

### KARMA function settings . . . . . 172

- KARMA function settings in Program mode . . . . . 172
- KARMA function settings in Combination mode . . . . . 176
- KARMA function settings in Sequencer mode . . . . . 180
- Synchronizing the KARMA function . . . . . 182

## Drum Track function . . . . . 185

### Overview . . . . . 185

- What is the Drum Track function? . . . . . 185

### Performing with the Drum Track function . 185

- Using the Drum Track function in Program mode . . . . . 185
- Using the Drum Track function in Combination mode . . . . . 187

### Drum Track function settings . . . . . 189

- Drum Track function settings in Program mode . . . . . 189
- Drum Track function settings in Combination mode . . . . . 190
- Drum Track function settings in Sequencer mode . . . . . 191
- Using the KARMA and Drum Track functions together . . . . . 191
- Synchronizing the Drum Track function . . . . . 193

### Creating a Drum Track pattern . . . . . 195

- Preparing a user pattern . . . . . 195
- Converting to a Drum Track pattern . . . . . 195

## Other functions common to all modes . . . . . 197

- Editing names . . . . . 197
- Setting the functions of SW1 and SW2 . . . . . 198
- Setting the functions of Realtime Controls Slider 5–8 . . . . . 198
- Using tap tempo . . . . . 199
- Resetting controller values . . . . . 199
- Shortcuts . . . . . 200

## Appendices . . . . . 201

### Restoring the factory settings . . . . . 201

- Loading the preloaded data . . . . . 201

### Installing options . . . . . 202

- Cautions when installing an option board . . . . . 202
- Available option boards for the M3 . . . . . 203
- Verifying installation . . . . . 203
- Installing the options and replacing the calendar battery . . . . . 204

### Troubleshooting . . . . . 208

- Power supply . . . . . 208
- Display . . . . . 208
- Audio input and output . . . . . 208
- Programs and Combinations . . . . . 210
- Songs . . . . . 210
- Sampling . . . . . 211
- KARMA function . . . . . 211
- Drum Track function . . . . . 212
- X–Y control . . . . . 212
- Drum Kits . . . . . 212
- Effects . . . . . 212
- MIDI . . . . . 212
- Pads or damper pedal do not respond correctly . . . . . 213
- USB Media, and CD . . . . . 213
- WAVE files . . . . . 214
- Connections with a computer . . . . . 214
- Included CD-ROM . . . . . 214

### Error messages . . . . . 215

- Error and confirmation messages . . . . . 215

### Media that can be used with the M3 . . . . . 223

- Types of media supported by the M3 . . . . . 223
- Operations that the M3 can perform on media . . . . . 223

### Specifications and options . . . . . 224

- Specifications . . . . . 224
- Options . . . . . 227

### MIDI Implementation Chart . . . . . 228



# Quick Start

This Quick Start is provided for those who just want to get started trying out the sounds right away.

It explains how to set up the M3, how to select programs and control the sound, and how to listen to the demo songs.

After you've finished reading this Quick Start section, please also take a look at the full explanations that follow.

## Setup

Here's how to connect the power cable and audio cables, and how to turn on the power.

- 1. If you purchased the M3-61/73/88 (the M3-M with the KYBD-61/73/88 keyboard assembly), you can use your system with the M3-M (module) tilted upward relative to the KYBD-61/73/88. Refer to the "Keyboard assembly Manual" included with the M3-61/73/88.**

If you purchased the M3-M (module) by itself, you can connect the included brackets and place the module at an angle on a tabletop or other surface. Refer to the "Connecting the brackets" document included with the M3-M.

- 2. Connect the included power cable.**

First connect the included power cable to the M3's power connector.

- 3. Connect the M3 to your mix or monitor system.**

Connect the M3's AUDIO OUTPUT (MAIN) L/ MONO and R jacks to your mixer or amplified monitor speakers.

If you're monitoring through headphones, connect them to the headphone jack located on the rear of the M3. The headphones will output the same sound as the AUDIO OUTPUT (MAIN) L/MONO and R jacks.

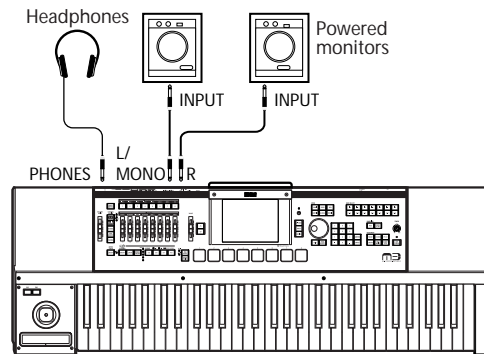

M3-61/73/88

If you're using the M3-M by itself, connect your MIDI master keyboard to it.

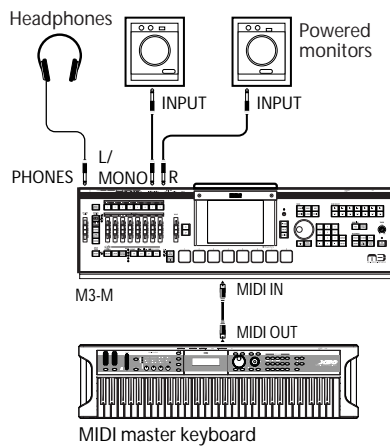

- 4. Lower the M3's VOLUME MAIN slider.**

Turn on your audio monitor system and set the volume to a normal level.

- 5. Turn on the M3 by pressing the power switch located on the rear panel.**

- 6. Raise the volume of the connected equipment to an appropriate level. Then gradually raise the M3's VOLUME MAIN slider to adjust the volume as desired.**

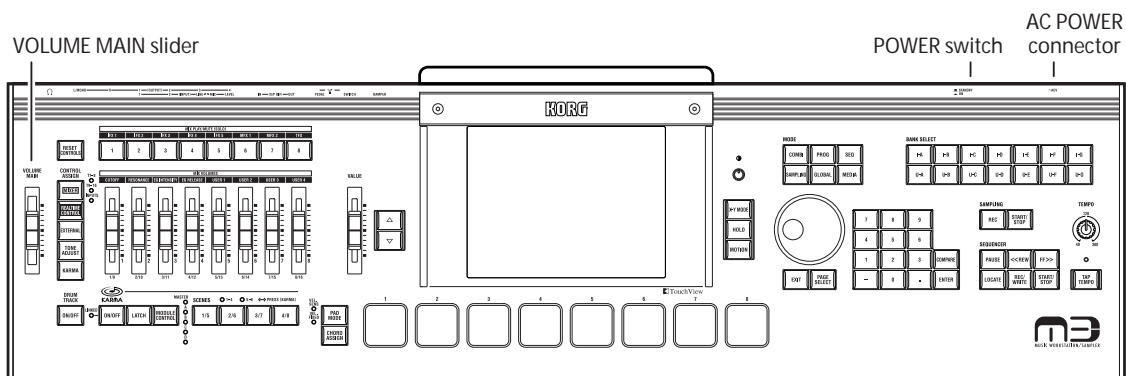

# Playing Programs and Combinations

By default, Combination mode will be selected when you turn on the power. Play the keyboard, and you will hear the sound of bank I-A combination number 000. A combination consists of up to sixteen programs that are split and/or layered. It also uses up to four KARMA modules simultaneously (a program can use only one KARMA module), letting you produce far more complex sounds than a program.

Although you could simply continue selecting different combinations and playing them, let's start by selecting and listening to the "basic" sounds of the M3 - programs.

*Note:* If you don't hear any sound when you play the keyboard or pads: Check the connections once again. Also make sure that the M3's VOLUME MAIN slider and the volume of your powered speakers or stereo amp are turned up appropriately.

## Selecting Programs

1. Press the **MODE PROG** switch (the LED will light) to enter Program mode.
2. The upper left of the display shows the name of the current page, **Prog P0: Play**. This is the page in which you will normally play programs.

Play the keyboard or strike the pads to hear the sound.

*Note:* If you moved to another page etc. by pressing the display, pressing the EXIT switch a maximum of three times will take you back to the program name selection.

3. The large characters in the upper part of the display will be highlighted.

These are the program number and program name ("Program Select").

In this state, you can press the  $\Delta$  switch or  $\nabla$  switch to select the next or previously numbered program.

You can turn the VALUE dial to rapidly scroll through the programs.

4. Use the **BANK SELECT I-A-I-G** and **U-A-U-G** switches to select other banks of programs.

With the factory settings, numbers 0-127 of INT-A-INT-D contain preloaded programs. Select and play these programs to hear their sounds.

For details on the programs in each bank, please see "Overview: Program Banks" on page 38.

5. Press the **popup button** located at the left of "Program Select" in the display.

A list of the programs in each bank will appear.

Use the tabs located at the left and right to select the desired bank.

Then press a program within the menu to select it. By using the scroll bar located below the menu you can view the other programs in that bank that are not currently displayed.

You can press the  $\Delta$  switch or  $\nabla$  switch to select the program of the previous or next number.

When you've chosen the program you want to play, press the OK button or the ENTER switch.

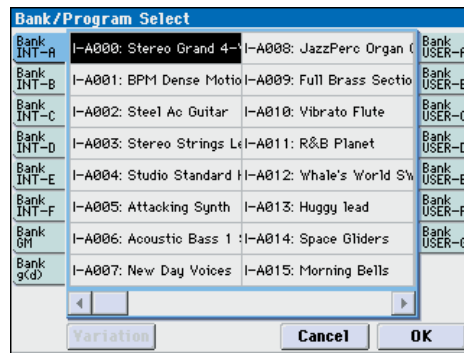

6. There are several other ways to select programs, but here we'll explain how to select programs using categories such as "keyboard," "organ," "bass," or "drums."

Press the Category Select popup button in the display. This is the rectangular button located above the program name.

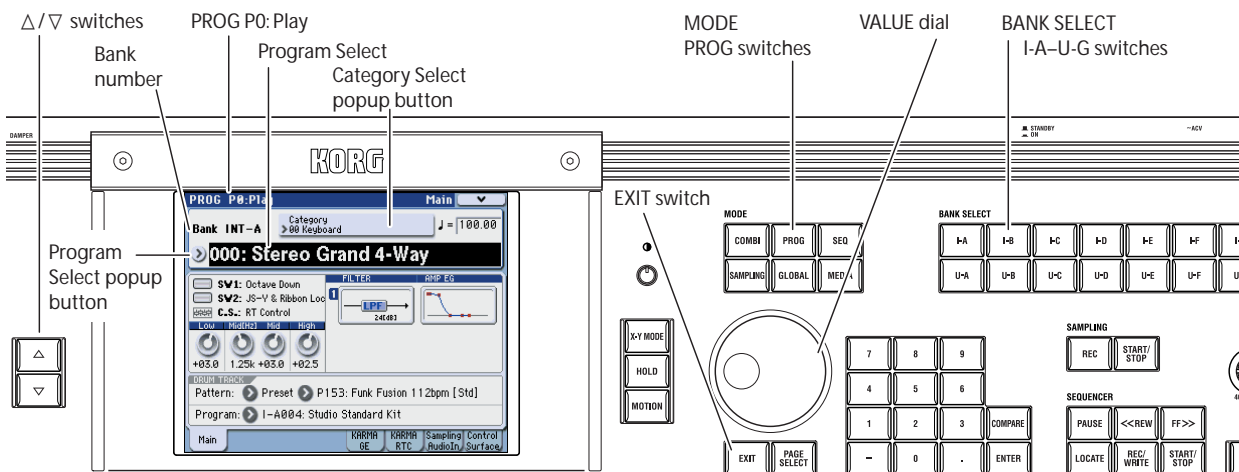



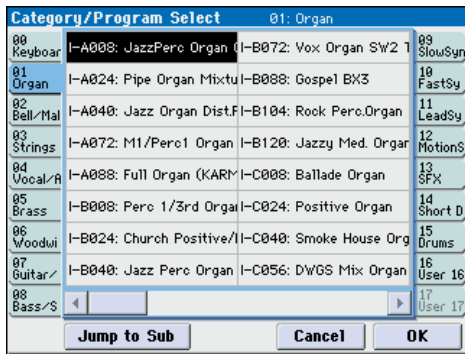

The Category/Program Select menu will appear, showing a list of the programs for each category. Press the tabs located at the left and right to select the desired category.

Then press a program in the menu to select it.

You can press the  $\Delta$  switch or  $\nabla$  switch to select the program of the next or previous number.

When you've chosen the program you want to play, press the OK button or the ENTER switch.

Categories also have sub-categories, and you can press the Jump to Sub button of the Category/Program Select menu to choose programs from a sub-category list.

### Selecting combinations

1. Press the MODE COMBI switch (the LED will light) to enter Combination mode.
2. The upper left of the display shows the name of the current page, Combi P0: Play. This is the page in which you will normally play combinations.

Play the keyboard or strike the pads to hear the sound.

Note: If you moved to another page etc. by pressing the display, pressing the EXIT switch a maximum of three times will take you back to the combination name selection.

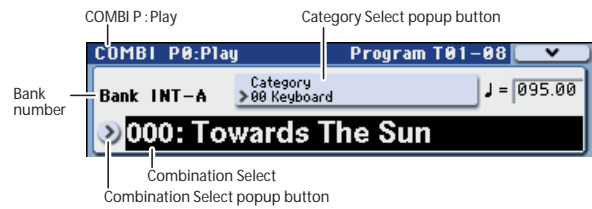

3. The large characters in the upper part of the display will be highlighted.

These are the combination number and combination name ("Combination Select").

In this state, you can press the  $\Delta$  switch or  $\nabla$  switch to select the next or previously numbered combination.

You can turn the VALUE dial to rapidly scroll through the programs.

4. Use the BANK SELECT I-A-I-G and U-A-U-G switches to select combinations of other banks.

With the factory settings, numbers 0-127 of INT-A-INT-C contain preloaded programs. Select and play these combinations to hear their sounds.

5. As in Program mode, you can select combinations from the menu by bank or by category.

As described in steps 5 and 6 of "Selecting Programs" on page 2, go ahead and select and play combinations in the same way as you did for programs.

### Using controllers to modify the sound

The M3 has numerous controllers.

1. The keyboard section of the M3-61/73/88 (the KYBD-61/73/88 keyboard assembly) provides a joystick, ribbon controller, and SW1/SW2 switches in addition to the keyboard, and you can use these to modify the sound.

The result will differ for each Program and Combination, so try them out to hear what happens. For details on these controllers, please see "Using Controllers" on page 41.

2. At the left side of the M3-M (the M3's sound module), there is a group of sliders and switches that looks somewhat like a mixer.

This is called the "control surface," and lets you perform various types of control such as editing

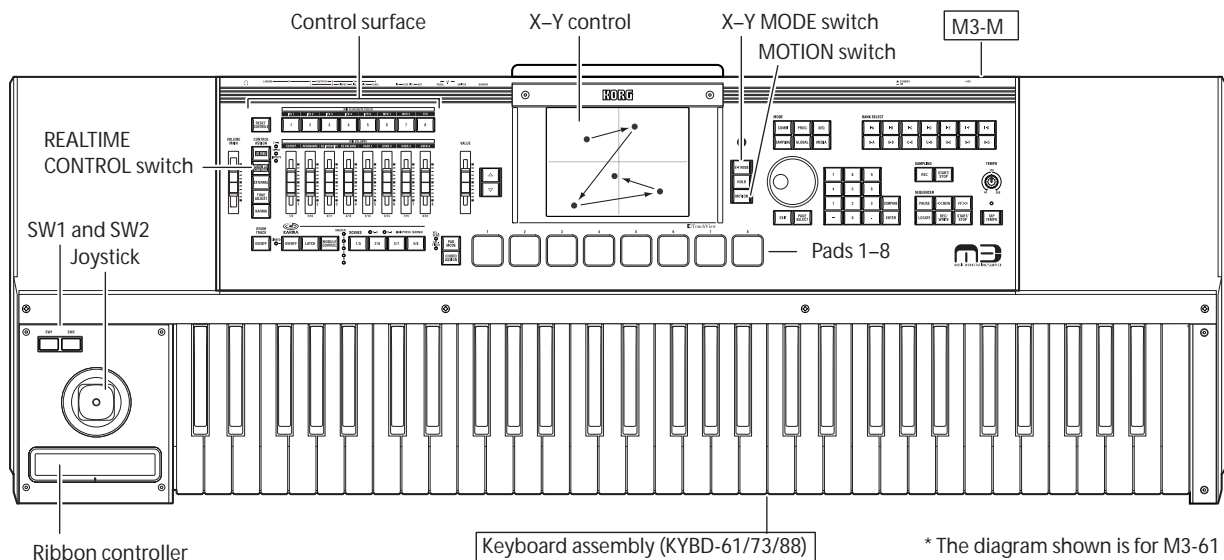

\* The diagram shown is for M3-61

sounds, operating the KARMA function, or sending MIDI messages to external devices.

For example, go ahead and press the CONTROL ASSIGN REALTIME CONTROL switch (the LED will light).

Now you can use the switches of the control surface to turn the effects on/off.

Operating the sliders will control the frequency cutoff, resonance, and intensity, or any other parameters you specify.

The display can show the function and values of the control surface. To view this, press the Control Surface tab located in the lower right of the display.

When you operate the controllers, the objects in the display will move accordingly.

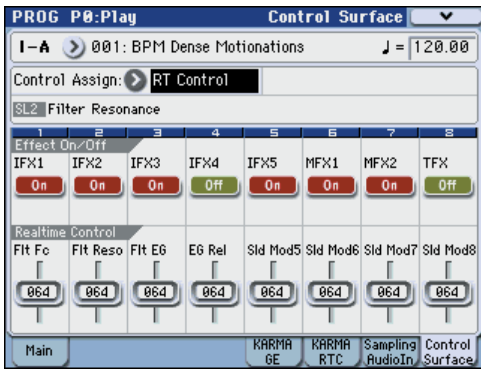

*Note:* Even if you've modified the sound, you can restore the program to its saved condition.

Press the COMPARE switch (the LED will light) to recall the saved settings from before you modified the sound. Press the COMPARE switch once again and you'll return to your modified settings (the LED will go dark).

You can load previously-saved settings by holding down the RESET CONTROLS switch and operating a control surface slider or switch, or pressing a CONTROL ASSIGN switch (see page 199).

**3. X-Y control is a particularly interesting capability of the M3.**

This lets you modify the volume balance or sound by sliding your finger across the display. You can also capture this motion and play it back during your performance to modify the volume balance or sound.

Press the X-Y MODE switch (the LED will light). The color of the display will change. While you play the keyboard, touch the display with your finger and make a motion. The color of the display will change, and you'll hear the volume balance or sound change simultaneously.

If you hold down the MOTION switch, the captured motion will be reproduced; you'll see the display change color, and hear the volume balance or sound change.

For details on operation and capturing motions, please see "X-Y controller" on page 43.

⚠ If the X-Y MODE switch is on (the LED will light), you won't be able to select parameters in the display. If you need to select a program or combination, or change a setting, turn the X-Y MODE switch off (the LED will go dark).

**4. Located below the display are eight velocity-sensitive trigger pads.**

You can use these to trigger single notes or chords (of up to eight notes).

This is a useful way to play drums, chords, or the KARMA function. You can easily assign notes or chords to the pads (see page 44).

**Performing with the KARMA function**

KARMA is an extremely powerful performance tool that allows a broad range of musical expression.

1. Select Combination mode or Program mode.
2. Press the KARMA ON/OFF switch (the LED will light).
3. If you press the KARMA LATCH switch (the LED will light), the KARMA function will continue generating the pattern or phrase even after you stop playing the keyboard or pads, or after all MIDI note-on/off messages are received.

For example, this is convenient when you want to play the keyboard while listening to the phrases generated by KARMA.

**4. Play the keyboard or pads to trigger KARMA.**

KARMA will begin generating its performance.

*Note:* If the KARMA LINKED LED is lit, the performance will not begin when you simply play the

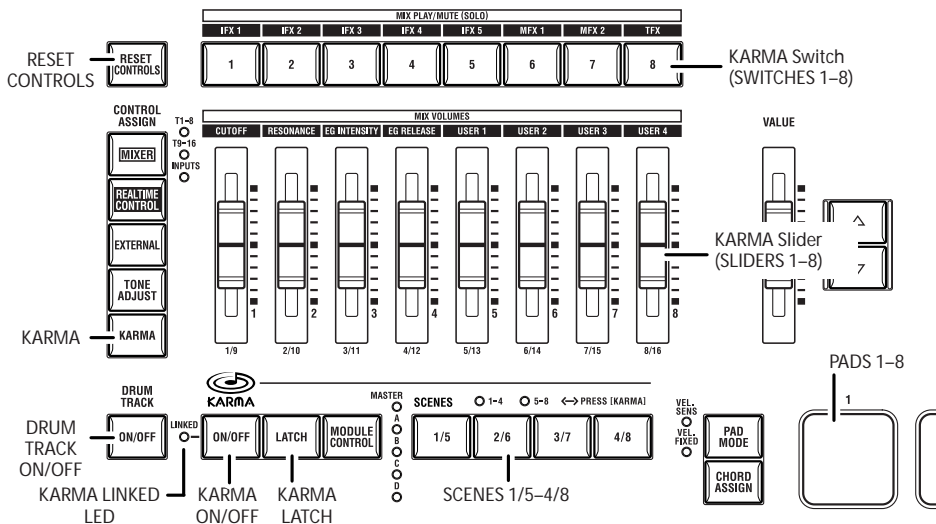

keyboard or pads. You must also press the DRUM TRACK ON/OFF switch and then press a key or pad to start the drum track phrase. The KARMA performance will begin simultaneously.

- KARMA has up to eight scenes. When you press one of the SCENES 1/5–4/8 switches to change scenes, the KARMA parameter values assigned to the KARMA switches and KARMA sliders will change instantly, giving you a wide range of variety in the generated phrases and patterns.**

The KARMA sliders and KARMA switches are assigned to the parameters that will be most effective in varying the phrases and patterns.

The KARMA SCENES 1/5–4/8 switches can select either KARMA scenes 1–4 or scenes 5–8. When you press the CONTROL ASSIGN KARMA switch that is already lit, the 1–4 or 5–8 LED will blink to indicate the scene that will be selected next. Then press one of the 1/5–4/8 switches to select the corresponding KARMA scene (see page 11).

- You can view the KARMA scene settings in the display.**

Press the EXIT switch three times to access the P0: Play page, and press the Control Surface tab located in the lower right of the display. Then press the CONTROL ASSIGN KARMA switch.

- By operating SLIDERS 1–8 and SWITCHES 1–8 of the control surface, you can edit the parameters assigned to the KARMA switches and KARMA sliders of a KARMA scene in realtime.**

The parameters that are assigned will differ depending on the Program or Combination.

*Note:* Even if you've modified the sound, you can restore the program to its saved condition. The same is true for KARMA settings (see page 3).

- The KARMA GE page and KARMA RTC page within the P0: Play page let you see these settings in greater detail. In the KARMA GE page you can select the GE (Generated Effect) used by a KARMA module, and view settings such as the time signature of the patterns that are generated.**

## Performing with the Drum Track function

The Drum Track function gives you an easy way to play a wide variety of Drum Track patterns using the M3's high-quality drum programs. Playing a Program or Combination along with Drum Track patterns is a convenient way to come up with phrases or work out the structure of your song.

- Select Combination mode or Program mode.**

For this example, press the MODE PROG switch to select Program mode, and access the Prog P0: Play–Main page. If another page is displayed, you'll need to press the EXIT switch up to three times.



- Press the DRUM TRACK ON/OFF switch.**

The ON/OFF switch will be lit or blinking. This will depend on the setting of the program.

If it's lit, the Drum Track pattern will begin. Press the ON/OFF switch once again to stop.

If it's blinking, the Drum Track pattern will be waiting to begin. It will start when you play the keyboard or when a MIDI note-on is received.

If the front panel KARMA LINKED and KARMA ON/OFF switches are lit, the KARMA performance will be linked with Drum Track start/stop. The way to stop the drum track will depend on the program settings; it will stop either when you press the DRUM TRACK ON/OFF switch or when you take your hand off the keyboard.

- To change the Drum Track pattern, use "Pattern Bank" and "Pattern No." to select the desired pattern.**

*Note:* You can create your own original Drum Track patterns (see page 195).

- Use "Drum Track Program" to select the program that will be played by the Drum Track pattern.**

*Note:* Only programs of category number 15 (Drums) can be selected.

## Listening to the demo songs

### Loading the demo song data in Global mode

- Press the MODE GLOBAL switch (the LED will light) to enter Global mode.**
- Access the Global P0: Basic Setup page.**  
If another page is displayed, press the EXIT switch.
- Press the menu button in the upper right of the display, and choose "Load Preload/Demo Data."**

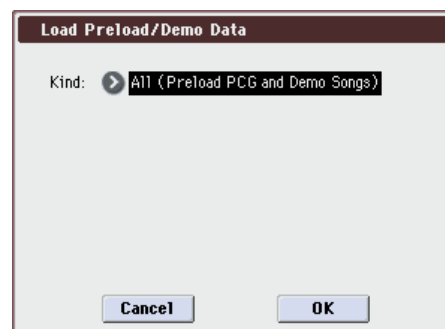

**4. In the “Kind” field, choose “All (Preload PCG and Demo Songs).”**

When you execute loading, the preloaded data and the demo song data will be loaded.

⚠ If you’ve edited a preloaded program or combination, or created one from scratch, executing this Load operation will overwrite your data; i.e., your changes will be lost. If you want to keep your changes, you must first save them on a USB storage device (commercially available) connected to the M3’s USB A connector.

**5. Press the OK button or ENTER switch.**

A dialog box will ask you for confirmation.

Press the OK button or ENTER switch once again to load the data.

⚠ Never turn off the power while data is being loaded.

If the Memory Protected dialog appears, press the System Pref. tab and clear the check mark from the Memory Protect **Song** setting. Then load the data again.

**Listening to the demo songs in Sequencer mode**

**1. Press the MODE SEQ switch (the LED will light) to enter Sequencer mode.**

**2. Access the P0: Play/REC- Program T01-08 page.**

If this page is not displayed, you’ll need to press the EXIT switch up to three times.

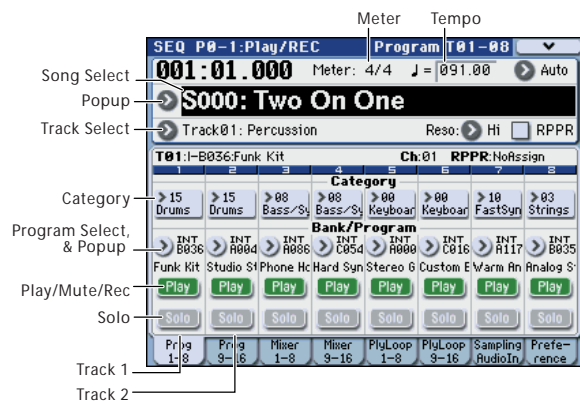

**3. Let’s start by listening to song S000.**

Verify that song S000 is selected. If another song is selected, press the song name display area (**Song Select**) to highlight it. Then press the numeric key 0, and then the ENTER switch.

**4. Press the SEQUENCER START/STOP switch.**

The LED will blink, and the song will begin playing back.

**5. If you want to stop playback mid-way through the song, press the START/STOP switch once again.**

**6. Let’s listen to the next song.**

Press the song name display area (**Song Select**). Press numeric key 1, and then press the ENTER switch. (Song “S001” will be selected.)

Alternatively, you can press the round button (Song Select popup) located at the left of the song name, and a list of song names will appear. Select a song, and press the OK button or ENTER switch.

**7. Press the SEQUENCER START/STOP switch to begin playback. To stop playback, press the START/STOP switch once again.**

⚠ The demo song will not be retained when the power is turned off, but you can load it again at any time.

**Playing back a cue list**

Songs can be assigned to a cue list, and will playback in the specified order. You can also specify the number of times that each song will be repeated. Here’s how to play back the demo songs assigned to a cue list.

**1. Access the P11: Cue List page.**

Press the PAGE SELECT switch to access the Seq Page Select page. Press “P11 Cue List” in the display.

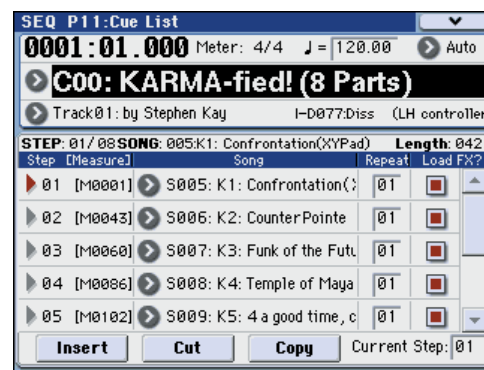

**2. Press the SEQUENCER START/STOP switch.**

You will hear the songs in the list in the assigned order. If you want to stop playback before you reach the end of the list, press the START/STOP switch once again.

This completes our quick start.

Of the M3’s wide range of functionality, this operation guide explains how to use some of the most typical operations. We highly recommend that you take the time to read it completely.

# Introduction to the M3

## Main Features

### Rich and vivid sound produced by new EDS (Enhanced Definition Synthesis) sound generator

The new “EDS” (Enhanced Definition Synthesis) sound generation system is based on PCM sources refined using Korg’s proprietary voicing technology, and delivers rich and vivid sounds.

Each voice has oscillators (two oscillators allowing four-stage velocity switching/crossfading/layering) that can use up to eight (stereo) multisamples, up to four filters (two filters each with four modes and four routings), two amps, five LFOs, and five EGs, all available simultaneously. Maximum polyphony is 120 voices.

The oscillator section provides a total of 1,032 multisamples (including seven stereo multisamples) sampled at 48 kHz, as well as 1,606 drum samples (including 116 stereo drum samples), giving you a total of 256 Mbytes of sample data (when considered as 16-bit linear data). These PCM sources are available for use in the oscillator section via four-way velocity switching/crossfading/layering to create a broad range of expressive, high-quality sounds.

The filter section that’s so vital to creative sound-making lets you simultaneously use two filters for each oscillator. Filter types include low-pass, high-pass, band-pass, and band-reject (notch). You can use the two filters in any of four routings: single, serial, parallel, or 24 dB mode.

The amp section provides a driver circuit that adds edge and character to the sound.

The key tracking generator allows the filtering to vary according to the keyboard range; you can apply subtle filtering for convincing simulation sounds, or aggressive filtering that produces drastic changes in filtering as you play up or down the keyboard.

The M3 takes advantage of its lavish amount of available processing power to produce ultra-fast and ultra-smooth EGs (envelope generators) and LFOs.

EGs allow you to specify how the sound develops over time, from its onset to its end. The each EG stage (attack, decay, slope, and release), giving you detailed control over how the tone and volume change over time, and making it possible to program anything from simulated acoustic sounds to vintage synthesizer sounds in the utmost detail.

Korg’s AMS (Alternate Modulation Sources) give you a rich array of modulation possibilities, with 50 different modulation sources you can use to control the sound in complex ways. The M3 takes this classic Korg feature even further, via the AMS Mixers. These let you create even more detailed modulation designs, such as mixing two modulation sources together, multiplying one modulation source by another, or modifying the shape of the modulation source in various ways.

Programs, Drum Tracks, and each of the sixteen timbres/tracks has its three-band EQ, letting you make detailed adjustments to the tonal character.

To let you shape the final character of the overall sound, the effect section provides up to five insert effects, two master effects, and one total effect. In addition to delay and reverb, the total of 170 high-quality effects includes modulation-type effects such as chorus, phaser, and flanger, dynamic-type effects such as compressor and limiter, and amp-modeling effects generated using Korg’s proprietary “REMS” modeling technology. There are also two common LFOs that can be shared between different modulation effects. For example, you can create sophisticated effects such as using a single common LFO to synchronize the modulation frequency of a phaser and a flanger used on different timbres. Effect dynamic modulation (Dmod) lets you control the sound or effects in a wide variety of ways, ranging from the subtle to the dramatic.

### Use the KARMA function, Drum Track function, Open Sampling System, and 16-track MIDI sequencer to bring your ideas into completion in this seamless new production environment

The M3 provides many new functions that help you turn your ideas into songs quickly and intuitively.

The Drum Track function lets you listen to drum patterns while you construct the outline of your song. You can easily select the M3’s built-in patterns or patterns that you’ve created, and start the pattern from a specified region of the keyboard or by playing a velocity higher than a specified threshold.

This function is also useful for anything from realtime performance to generating sketches for song production

The M3 also provides the amazing KARMA function, giving you an enormous amount of musically expressive potential. This provides a powerful boost to your music production power, letting you can use up to four KARMA modules to create complex layered textures or produce natural performance gestures that are idiomatic to a wide range of instruments.

Sampling functionality is provided by the Open Sampling System which lets you sample or resample while in any mode (Program or Combination, etc.). You can also perform a rich array of sample editing commands including Time Stretch and Time Slice. In Sequencer mode you can perform in-track sampling, letting you sample while your song plays back, just as if you were recording an audio track. In addition to Korg format sample data, you can also load sample data in a wide range of formats including WAVE, AIFF, Akai S1000/S3000, and SoundFont 2.0 formats for music production or performance.

Auto Song Setup is a function that makes it easy to record programs, drum tracks, or combinations along with KARMA performances as a multi-track recording to create the basic tracks at the core of your song.



At the heart of any music production is the M3's sequencer, which lets you record 16 MIDI tracks, up to 128 songs, and 210,000 notes. With a high resolution of 1/480, every timing nuance of your performance will be captured accurately. You can use the Cue List function to create your song section by section and then play it back as a medley in the form you want.

### **Superb operability and expressiveness, with X-Y Control that lets the display operate as a controller, eight multi-pads, and a control surface**

The M3 features a clear, color 320 x 240 pixel display for excellent visibility and operability. It features the Touch-View graphical user interface that lets you operate the system by touching the display directly, allowing efficient access to the M3's enormous amount of parameters.

This display also operates as an X-Y touchpad controller (similar to Korg's KOASS technology), allowing you to vary the volume balance or sound in realtime by moving your finger across the display (X-Y Mode). You can also record the movements of your finger and play back these movements to vary the sound (X-Y Motion).

The eight multi-pads can trigger single notes or chords (up to eight notes), and are a useful way to play drums, chords, or to control the KARMA performance. You can easily assign notes or chords to the pads as desired.

The eight sliders and switches of the control surface provide a high degree of expressive operability, and can be used to adjust the volume of oscillators or timbres/tracks, to control the realtime performance generated by KARMA, or to modify your sounds via the Realtime Control or Tone Adjust functions. You can also use these sliders and switches along with the pads as external controllers for your external MIDI equipment.

The keyboard assembly (KYBD-61/73/88) features a joystick newly designed for ease of use, as well as a convenient ribbon controller for detailed control over the nuances of your sound. The 61-key and 73-key models provide a great-feeling keyboard with aftertouch, allowing expressive control over any type of sound. The 88-key model features the RH3 (Real Weighted Hammer Action 3) keyboard with a heavier feel in the lower register that lightens as you play upward, allowing expressive performance with the same keyboard playing feel as a grand piano.

### **Excellent connectivity with up to four channels of audio input, six channels of audio output, and USB A and B**

As audio inputs, the M3 provides two channels of analog and two channels of digital (S/P DIF) input.

As audio outputs, it provides the two main analog channels (L/MONO, R), four independent outputs, and two digital channels (S/P DIF).

There's one type-B USB connector that allows MIDI to be sent and received between your computer and the M3, and two type-A USB connectors for connecting USB memory or other storage media. USB 2.0 is supported for high-speed transfer of large amount of data. You can resample to a USB storage device (such as a hard disk), or edit WAVE files. If you connect a

USB CD-RW drive, you can resample the songs you create and then use them to burn an original audio CD.

If the optional EXB-FW is installed, you can start up the included M3 Plug-In Editor in your DAW application, allowing you to send and receive MIDI messages as well as two-in/six-out streams of digital audio data between your software and the M3.

### **KKS (KORG Komponent System) allows flexible construction of your hardware system**

The M3 uses "KKS" (KORG Komponent System), in which the sound module and the keyboard assembly (KYBD-61/73/88) are joined by a detachable mechanism. This lets you mount other sound modules on the keyboard assembly, or mount two sound modules at the same time on the keyboard assembly for flexible system creation. Of course you can detach the sound module from the keyboard assembly and use it as a stand-alone unit. You can also tilt the sound module upward for convenient operation.

You'll be able to create flexible systems with future products that utilize the KKS standard.

### **Virtualized hardware functionality that lets you assign sounds just like plug-in instruments within your DAW software**

The bundled "M3 Editor" and "M3 Plug-In Editor" software are applications that let you edit M3 sounds such as programs, combinations, and drum kits from your computer.

"M3 Editor" is a stand-alone editor. "M3 Plug-In Editor" supports VST, Audio Units, and RTAS formats, allowing you to use the M3 as if it were a plug-in instrument in your DAW (Digital Audio Workstation) software or other host application.

If you install the optional EXB-FW FireWire board, you'll be able to connect a single FireWire (IEEE 1394) cable to route the M3's audio signals and MIDI messages to and from your DAW tracks via the M3 Plug-In Editor. This "Virtualized Hardware" functionality means that you can use the M3 as though it were a plug-in software instrument.

### **Expandable by a rich variety of separately sold options**

You can expand the M3's power by installing an EXB-RADIAS analog modeling synthesizer board (one timbre, maximum 24-voice polyphony), by adding the EXB-M256 to expand the internal PCM multisample and sampling capacity to 320 Mbytes (64 Mbytes internal + 256 Mbytes), the EXB-FW that allows single-cable FireWire (IEEE 1394) connection for creating a virtualized hardware environment, and EX-USB-PCM series libraries that will become available in the future.



# Front and rear panels

## Front panel

### M3 Front panel

The M3 music workstation/sampler uses the “KORG Komponent System,” with the KYBD-61/73/88 keyboard assembly and the M3-M sound module in a detachable configuration.

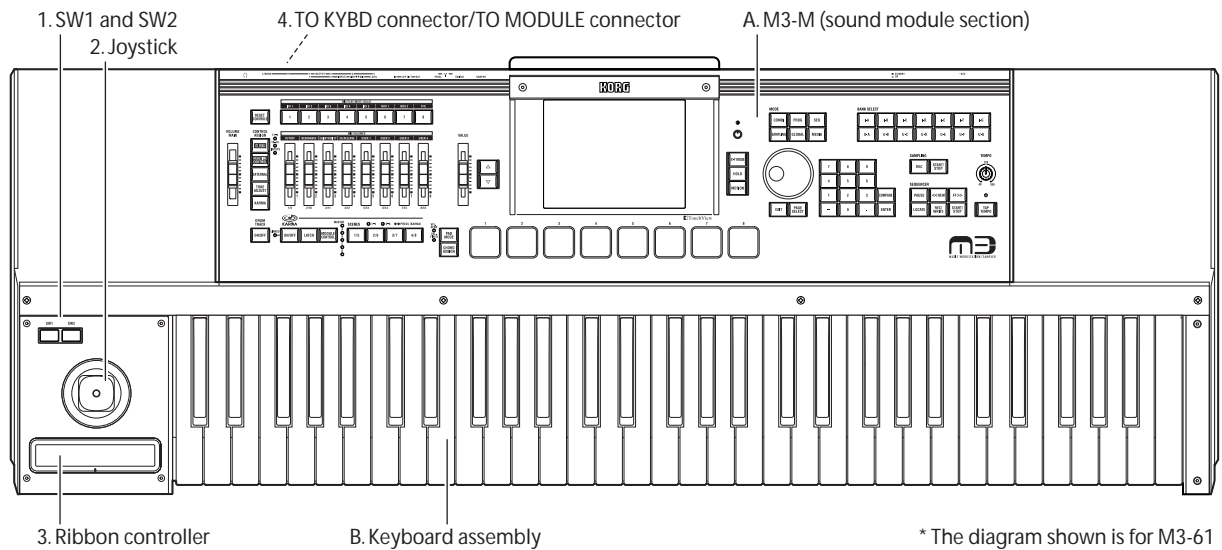

#### A. M3-M (sound module section)

This is the M3-M sound module.

You can use the M3-M attached to the KYBD-61/73/88 keyboard assembly, or use the M3-M by itself as a MIDI sound module with an external MIDI keyboard or controlled from your computer.

They will do something like the functions shown below:

#### Standard Joystick functions

Move the joystick...	Controller Name	Normally controls...
Left	JS-X	Pitch bend down
Right	JS+X	Pitch bend up
Up (away from yourself)	JS+Y	Vibrato
Backwards (towards yourself)	JS-Y	Filter LFO (wah)

#### B. KYBD-61/73/88 keyboard assembly

This is the KYBD-61/73/88 keyboard assembly. Connect it to the M3-M. For details on how to connect this to the M-3M and how to use it, please see “Keyboard assembly Manual.”

#### 1. SW1 and SW2

These are used to control the M3-M’s program parameters or effect parameters, or to turn the joystick or ribbon controller’s lock function on/off.

The actual functions that are being controlled will depend on various program and effect parameters.

#### 3. Ribbon controller

You can control the M3-M’s program parameters and effect parameters by touching or sliding your finger on the ribbon controller.

The actual functions that are being controlled will depend on various program and effect parameters.

#### 2. Joystick

You can control the M3-M’s program parameters or effect parameters by moving the joystick up/down/left/right.

The actual functions that are being controlled will depend on various program and effect parameters.

#### 4. TO MODULE , TO MODULE (2nd) connectors

Use the included cable to connect the M3-M and the keyboard assembly. When they are connected, you can use the keyboard assembly’s keyboard, SW1 and SW2 switches, joystick, and ribbon controller to control the M3-M. The KYBD-61/73/88 keyboard assembly has two TO MODULE connectors (main and sub), allowing you to connect two devices that are compatible with the KORG Komponent System. For details on connections, please see “Keyboard assembly Manual.”

## M3-M Front panel

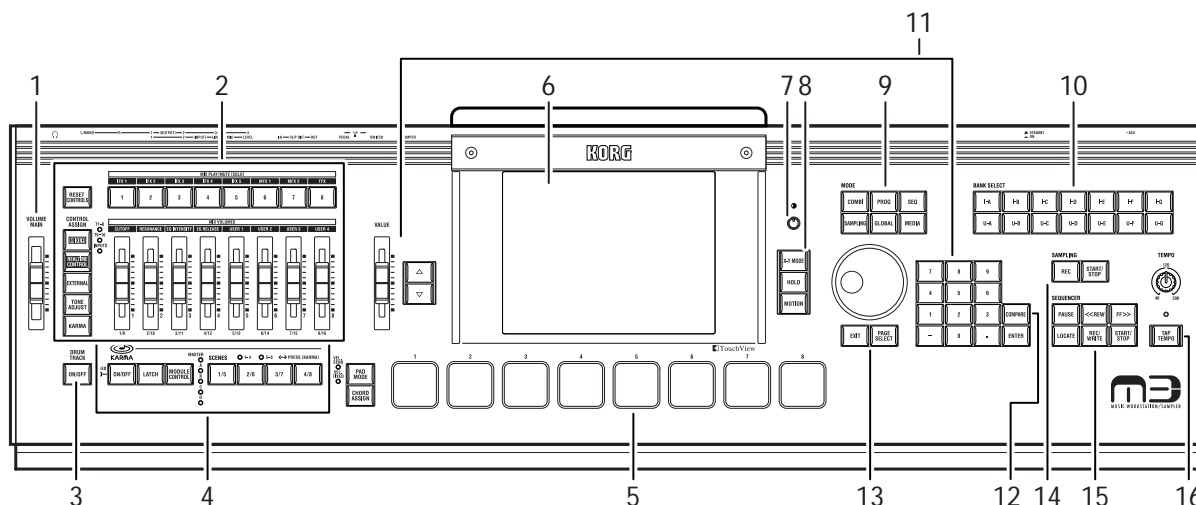

### 1. VOLUME MAIN slider

This adjusts the volume of the (MAIN OUTPUT) L/MONO, R outputs, as well as the volume of the headphone jack.

It does not affect any of the other outputs, including S/P DIF OUT (MAIN), the AUDIO OUTPUT (INDIVIDUAL) 1-4, or the optional EXB-FW output.

### 2. Control Surface (MIXER & MODULATION)

The Control Surface is located at the left of the display, and consists of eight sliders, eight switches, and a control assign section that selects the function to be controlled.

You can use the Control Surface to perform a wide range of control, such as adjusting the oscillator, timbre, track, and audio input mixers, editing sounds, controlling the KARMA function, and transmitting MIDI messages to external devices. You can freely switch the Control Surface between these functions without losing the contents of your editing.

As explained below, you can use the front panel CONTROL ASSIGN switches to switch between the various control surface functions. You can also view and edit the control surface settings on the display (P0-Control Surface page in each mode).

### CONTROL ASSIGN:

#### MIXER switch

**T1-8, T9-16:** In Program mode, the control surface will control the volume, play/mute, and solo of oscillators 1 and 2 and the Drum Track.

In Sampling mode, the control surface will control the volume, play/mute, and solo of the multisamples (oscillators).

In Combination and Sequencer modes, the control surface will control volume, play/mute, and solo of the sixteen timbres or MIDI tracks.

**INPUTS:** The control surface will control the volume, play/mute, and solo of the analog audio input and the S/P DIF audio input (and the FireWire L/R audio input if the optional EXB-FW is installed).

The LEDs at the right of this switch indicate whether you've selected timbres or tracks 1-8 or 9-16, or INPUTS. Press the MIXER switch to change the selection.

#### REALTIME CONTROL switch

Switches 1-8 will turn the effects on/off. Sliders 1-8 will modify the sound or effects.

#### EXTERNAL

**EXTERNAL** lets you use the control surface to transmit MIDI messages to external MIDI devices.

#### TONE ADJUST

**TONE ADJUST** gives you hands-on access to sound editing, using the sliders 1-8, and switches 1-8. In Combination and Sequencer modes, it also lets you edit Programs within the context of the Combination or Song, without making any changes to the original Program data.

#### KARMA switch

Sliders 1-8 and switches 1-8 will control the KARMA function.

Alternatively, they will switch between KARMA SCENES 1-4 and 5-8. (see page 11)

#### MIX PLAY/MUTE (SOLO), IFX 1...5, MFX1, 2, TFX

#### SWITCHES 1-8

These switches will control the function you've selected in the CONTROL ASSIGN section.

*Note:* Use the menu command **Panel-SW Solo Mode On** to switch these between the PLAY/MUTE function and SOLO On/Off function.

#### MIX VOLUMES, CUTOFF...EG RELEASE, USER1...4

#### SLIDERS 1/9-8/16

These sliders will control the function you've selected in the CONTROL ASSIGN section.

 There will be a slight discrepancy between the value and the controller position when you move a controller near the minimum or maximum position of the slider.

For details, please see:

Program mode: “0–8: Control Surface” on page 14 of the Parameter Guide

Combination mode: “0–8: Control Surface” on page 130 of the Parameter Guide

Sequencer mode: “0–2–8: Control Surface” on page 207 of the Parameter Guide

Sampling mode: “0–8: Control Surface” on page 309 of the Parameter Guide

### RESET CONTROLS switch

This switch resets the controllers of the control surface, or returns the settings to stored values.

To reset a single control, hold down RESET CONTROLS switch and then move a Control Surface slider, press one of the control surface switches.

To reset an entire page of the control surface all at once, including all sliders, and switches, hold down RESET CONTROLS switch and then touch any of the CONTROL ASSIGN switches, such as REALTIME CONTROL or TONE ADJUST.

For details, please see “Resetting controller values” on page 199.

## 3. DRUM TRACK

### DRUM TRACK ON/OFF switch

This switch turns the Drum Track function on or off.

When the DRUM TRACK ON/OFF switch is off (the LED will go dark), pressing this switch will make the LED light or blink.

If the LED lights, the Drum Track pattern will start simultaneously. When you turn it off, the pattern will stop.

If the LED is blinking, the Drum Track pattern will be in ready mode; it will start when you play the keyboard or receive a MIDI note-on message.

## 4. KARMA

KARMA stands for “Kay Algorithmic Realtime Music Architecture.” It’s an immensely powerful recording and live performance tool, which can provide a wide range of musical effects including:

- Arpeggiation
- Drum and instrument grooves
- Complex CC gestures (as if it was automatically moving sliders or joysticks for you)
- Musical phrase generation, such as piano flourishes
- Gated and chopped dance production effects
- Any combination of the above
- ...and much more.

### ON/OFF switch

This switches the KARMA function on and off. As with the other KARMA switches, the switch’s LED will light up to show you that it is turned on.

### LINKED LED

This will light if **Link to DT** of each KARMA module is on. If this is lit, the KARMA function on/off status will be controlled in synchronization with the on/off status of the Drum Track function.

### LATCH switch

When LATCH is turned on, KARMA will continue to play even after you’ve stopped holding notes on the keyboard, drum/chord pads, or MIDI In.

This is convenient when you want to play on top of a KARMA-generated groove, for instance.

### MODULE CONTROL switch

In Combination and Sequencer modes, KARMA has four independent Modules, each of which can be generating a different musical effect. When used to control KARMA, the Control Surface sliders and switches are five layers deep: one for each Module (A–D), and then a Master Layer which controls selected parameters from all of the Modules at once.

The **MODULE CONTROL** switch selects whether the KARMA Sliders, Switches, and Scenes will control either a single Module independently, or the Master Layer. In Program mode, only a single Module is available, and the Master Layer is used to control it; you cannot select other settings).

### SCENES

#### SWITCHES 1/5...4/8

These switches select KARMA scenes 1–8.

When you press the CONTROL ASSIGN KARMA switch, the 1–4 or 5–8 LED will blink to indicate the candidates for the selection you are about to make. When you then press a switch 1/5–4/8, the corresponding KARMA scene will be selected.

If you once again press the KARMA ON/OFF switch while 1–4 or 5–8 are blinking, the blinking state will be cancelled.

## 5. Drum/Chord Pads

### PAD 1...8

These velocity-sensitive pads can trigger single notes or chords of up to eight notes each. You can use them for playing or programming drums, for triggering chords (especially useful in conjunction with KARMA), or for selecting chords to play from the keyboard in Chord mode. For information about Chord mode, please see “Assigning notes and chords to pads” on page 44.

Assigning notes to the pads is fast and easy.; see “CHORD ASSIGN switch” on page 12 for details.

The notes and/or chords assigned to the pads are stored with each Program, Combination, and Song. There are also Global settings for use when the Control Surface is set to EXTERNAL, for easy control of external sound modules or plug-ins.

### PAD MODE switch

The PAD MODE switch switches the pads between being velocity sensitive (so that the loudness varies depending on how hard you hit the pad) and playing a single, fixed velocity for each note (handy if you want

the same results every time, regardless of how hard you play).

### CHORD ASSIGN switch

Use this switch to assign single notes or chord to the pads. (See “Assigning notes and chords to pads” on page 44)

## 6. TouchView display

This is a touch panel featuring the TouchView system. You can select pages, tabs, and parameters by pressing objects shown in the display, and then specify their value in the display or by using the VALUE controllers. This allows quick and intuitive editing.

This display also functions as an X–Y controller. You can assign oscillator or timbre/track volume, program parameters, or effect parameters to the X-axis and Y-axis, and control them in realtime. When you do so, the color of the display will change in response to the movement of your finger. You can also use X–Y Motion to capture the movement of your finger, and use this captured motion to control parameters.

## 7. Contrast knob

This adjusts the contrast of the display. Adjust this as necessary if the visibility is not optimal.

## 8. X–Y control

X–Y control lets you use movements of your finger on the display (X–Y mode) or an X–Y Motion recorded in this way to control the volume balance between OSC1 and OSC2 (or between timbres/tracks), or to generate control changes that will modify the program or effect. The X–Y Volume Control and X–Y CC Control settings specify the function to be controlled. (See “Volume Control and CC Control” on page 62)

### X–Y MODE switch

This turns X–Y MODE on or off. If you turn this on and move your finger across the display, the volume or tone will change according to the function that is assigned.

If this is on, the switch will light and the color of the display will change.

 If this is on, you won't be able to select parameters in the display. Turn this off if you need to modify settings. For details on how to preserve the On state, please see page 141.

### HOLD switch

When you turn on the HOLD switch (the LED will light), the X–Y MODE effect will be maintained even after you take your hand away, preserving the state of that moment. If this HOLD switch is off, the point will return to the center value when you take your hand away.

### MOTION START/STOP switch

This records or plays-back an X–Y Motion. Recording or playback will occur while you continue pressing the switch (the LED will light). For details on how to play back an X–Y Motion, please see “X–Y controller” on page 43.

You can also use a foot switch to control the MOTION START/STOP switch function.

## 9. MODE switches

M3 has six different operational modes, each one optimized for a specific set of functions.

Press one of these switches (the LED will light) to enter the corresponding mode.

### COMBI switch

This selects Combination mode. Since a combination consists of multiple programs in a split or layer configuration, it can produce more complex sounds than a program. In Combination mode you can play or edit these combinations.

### PROG switch

This selects Program mode. Programs are the basic sounds you play. In Program mode you can play or edit programs.

### SEQ switch

This selects Sequencer mode, for recording, playing, and MIDI tracks.

### SAMPLING switch

This selects Sampling mode, for recording and editing audio samples and multisamples.

### GLOBAL switch

This selects Global mode, for making overall settings, and Drum Kits, and more.

### MEDIA switch

This selects Media mode. In this mode you can save or load data using a USB storage device connected to the USB A connector. You can also edit WAVE files on a USB storage device, or create an audio CD.

## 10. BANK SELECT switches

### I–A, I–B, I–C, I–D, I–E, I–F, I–G, U–A, U–B, U–C, U–D, U–E, U–F, U–G switches

Use these switches to change banks when selecting Programs or Combinations. The LEDs in the switches light up to show the current bank.

In Program mode, these switches select the Program bank.

In Combination mode, these switches have two functions:

- When you're selecting Combinations, they choose the Combination bank.
- When you're assigning a Program to a timbre within the Combination, they select the Program bank.

In Sequencer mode, when a track's Program name is selected, these switches change the Program bank.

## 11. VALUE controller

When you've selected a parameter on the TouchView display, you can edit it using any of the four front-panel VALUE controllers:

- The VALUE slider
- The Inc  $\Delta$  and Dec  $\nabla$  switches

- The VALUE dial
- The numeric keypad

### VALUE slider

Use this to edit the selected parameter's value. This control is convenient for making large changes to the value, such as moving quickly to the minimum or maximum setting.

You can use the value slider as a modulation source, but only when the following are true:

- You're on the Program mode P0: Play– Main page, and the big Program name is selected, or
- You're on the Combination mode P0: Play– Program T01–08 page, and the big combination name is selected.

In these cases only, the value slider sends MIDI CC#18, and can be used as a modulation source.

### Inc $\Delta$ and Dec $\nabla$ switches

These are used to increase or decrease the parameter value by individual steps. They're convenient for making fine parameter adjustments.

### VALUE dial

Use this dial to edit the selected parameter's value. This control is convenient when you want to scroll through a very long list of selections.

### 0–9, –, ., and ENTER switches

These switches are convenient when you know the exact value that you want to enter. Use the 0–9, –, and decimal (.) switches to enter the value, and then press the ENTER switch to confirm the entry.

The – switch inverts the sign (+/–) of the parameter value; the decimal (.) switch inserts a decimal, for entering fractional values.

### Functions that use the ENTER switch in conjunction with another switch

ENTER has a few special functions when it is pressed in combination with other switches.

Whenever a parameter on the display lets you enter a musical note (such as G4 or C#2), or a velocity level, you can enter the note or velocity directly by holding down ENTER while playing a note on the keyboard. (This is not available in menu command dialog boxes.)

By holding down the ENTER switch while you press a numeric key (0–9), you can select up to ten menu commands from the current page.

In Program and Combination modes, you can hold down the ENTER switch and press the SEQUENCER REC/WRITE switch to use the Auto Song Setup function. This imports the current Program or Combination into Sequencer mode for quick and easy recording.

While a dialog box is displayed, the ENTER switch corresponds to the OK button. (The EXIT switch corresponds to the Cancel button.)

In Sequencer mode, you can hold down the ENTER switch and press the LOCATE switch to operate the menu command **Set Location**.

## 12. COMPARE

### COMPARE switch

Use this switch to compare the sound of the Program or Combination that you are currently editing with the saved, un-edited version of the sound.

You can also use this switch to make “before and after” comparisons when recording or editing in Sequencer mode.

For details, please see “COMPARE switch” on page 23.

## 13. PAGE SELECT

Here you can select pages within each mode.

### PAGE SELECT switch

Press this switch when you want to move to another page. When you press this switch, a list of the pages within the mode will appear in the display. Press the button of the desired page. Alternatively, you can move to a page by holding down this button and pressing a numeric key 0–9.

### EXIT switch

If you're in a page other than page 0 (e.g., Prog P0: Play) of each mode, pressing this switch will take you to page 0.

This switch makes it easy to return to the main page of the current mode:

- Press it once to go to the previously-selected tab on the main P0 page.
- Press it again to go to the first tab on the main P0 page (such as the main Program Play page). If you had previously selected a parameter on this page, that parameter will be selected.
- Press it a third time to select the main parameter on the P0 page, such as the Program name in Program mode.

Wherever you are in Program, Combination, or Sequencer modes, pressing EXIT three times (or fewer) will take you back to Program/Combination/Song Select, where you can immediately use the numeric keys or  $\Delta$ / $\nabla$  switches to select a Program, Combination, or Song.

When a dialog box is open, this switch cancels the settings made in the dialog box and closes the dialog box, just like pressing the Cancel button. If a popup menu or menu is open, pressing EXIT closes the menu.

## 14. SAMPLING switches

### REC switch

In Sampling, Program, Combination, and Sequencer modes, pressing this switch enters the initial sampling-ready mode. The switch's LED will light up.

To continue, press the SAMPLING START/STOP switch, as described below.

### START/STOP switch

In Sampling, Program, Combination, and Sequencer modes, pressing this when the SAMPLING REC switch is lit will do one of three things, depending on the setting of the **Trigger** parameter (on the Sampling



mode P0: Recording– Audio In/Setup page, and P0–Sampling/Audio In page):

- If **Trigger** is set to **Sampling START SW**, sampling will begin immediately.
- If **Trigger** is set to **Note On**, sampling will begin as soon as you play a note on the keyboard.
- If **Trigger** is set to **Threshold**, sampling will begin as soon as the selected audio source reaches a preset volume level.

On the Sampling mode's P1: Sample Edit page, pressing this switch will play the selected sample.

This switch is also used to play back WAV files from the media. You can play back WAV files in the directory window of various Media mode pages, in the Media mode Make Audio CD page, in the Sequencer mode audio track editing dialog boxes, and in the **Select Directory** menu dialog box of the Program, Combination, Sequencer, and Sampling modes.

## 15. SEQUENCER switches

Most of the switches in this section apply only to Sequencer mode and audio CD playback (in Media Mode).

REC/WRITE is the exception; it has special functions in Program, Combination, and Global modes, as described below.

### PAUSE switch

In Sequencer mode, this switch pauses the playback of the song. When paused, the switch's LED will light up. Press PAUSE once again to resume playback, and the LED will turn off.

In Media and Sampling modes, this switch pauses audio CD playback.

### <<REW switch

In Sequencer mode, when the Song is playing or paused, this switch will rewind the song. When you press and hold this switch, its LED will light up, and the playback will rewind. (Rewind is disabled during recording, and while the Song is stopped.)

In Media and Sampling modes, this switch rewinds the audio CD.

### FF>> switch

In Sequencer mode, when the Song is playing or paused, this switch will fast-forward the song. When you press and hold this switch, the switch will light, and the playback will fast-forward. (Fast-forward is disabled during recording, and while the Song is stopped.)

In Media mode, this switch fast-forwards the audio CD.

### LOCATE switch

In Sequencer mode, this switch will advance or rewind the song to the specified locate point. This lets you jump immediately to any point in the current Song. The default locate point is the first beat of measure 1.

To set the locate point to the current position, hold down ENTER switch and then press LOCATE switch. You can also set the Locate point directly via the display menu.

### REC/WRITE switch

In Sequencer mode, pressing this switch will enter record-ready mode. Once you're in record-ready mode (shown by the switch's lit LED), you can begin recording by pressing the SEQUENCER START/STOP switch. For details, please see "Recording MIDI in real-time" on page 85.

In Program, Combination and Global modes, pressing REC/WRITE switch will open the Update dialog box. For details, please see "Using the (SEQUENCER) REC/WRITE switch to write" on page 140.

In Program and Combination modes, you can hold down the ENTER switch and press the SEQUENCER REC/WRITE switch to use the Auto Song Setup function. This imports the current Program or Combination into Sequencer mode for quick and easy recording. For details, please see "Recording the sound of a Combination or Program" on page 89.

### START/STOP switch

This starts or stops recording and playback in Sequencer mode.

In Media and Sampling modes, this switch starts and stops playback on the audio CD.

## 16. TEMPO controls

### TEMPO knob

This adjusts the tempo for the M3 as a whole, including:

- KARMA
- Drum Track
- Songs in Sequencer mode
- Tempo-synced LFOs
- Tempo-synced ("BPM") delay effects
- EXB-RADIAS modulation source (if the optional EXB-RADIAS is installed)

The LED will blink at quarter-note intervals of the current tempo.

*Note:* If the Global P1: MIDI– MIDI Basic page **MIDI Clock** parameter is set to **External**, or if it is set to **Auto** and a clock is currently being received via MIDI, then neither the TEMPO knob nor the TAP TEMPO switch will have any effect.

### TAP TEMPO switch

You can specify the tempo by repeatedly pressing this switch at regular intervals of the desired tempo. The tempo will be entered when you press the switch twice. To obtain better accuracy, you should press the switch multiple times.



## Rear panel/Bottom panel

### Rear panel

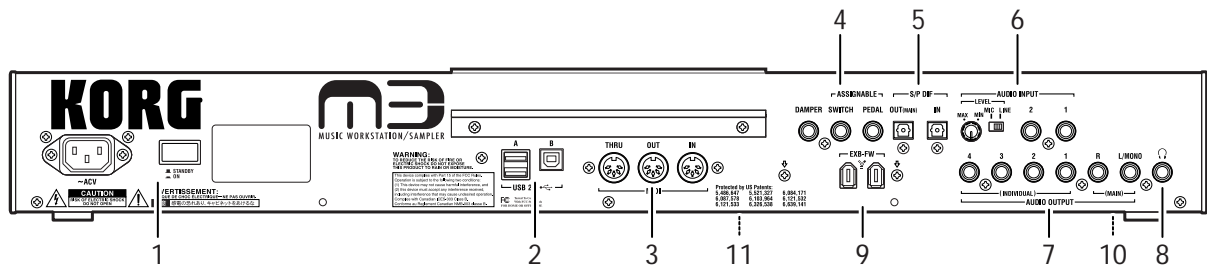

#### 1. AC Power

##### POWER switch

This switch turns the power on and off. Before turning M3 off, make sure that you've saved any edits to your Programs, Combinations, Songs, or other user data.

##### AC Power connector

Connect the included power cable here.

#### 2. USB 2.0

##### USB A connector

(for connecting Hard Disk, CD-R/RW drive, etc.)

This connector lets you connect external USB devices. You can use a USB hard disk or CD-R/RW drive to save or load M3 data such as PCG or SNG files, or WAVE files.

##### USB B connector

(for connecting to computer)

This connector lets you send and receive MIDI between the M3 and your computer.

##### What is USB?

USB stands for **U**niversal **S**erial **B**us, and is an interface for transferring data between a computer, and/or peripheral devices.

#### 3. MIDI

Connect these connectors between the M3 and external MIDI devices or a computer that is connected via a MIDI interface. MIDI allows you to send and receive performance data such as note messages as well as sound settings.

##### MIDI THRU connector

MIDI data received at the MIDI IN connector is re-transmitted.

You can use this to chain multiple MIDI devices together.

##### MIDI OUT connector

This connector transmits MIDI data.

Use this to control external MIDI devices, or to record into an external sequencer.

##### MIDI IN connector

This connector receives MIDI data.

Use this to play the M3 from another MIDI device, or from an external sequencer.

#### 4. Pedals

##### DAMPER jack

For the damper—also known as the sustain pedal—you can connect either a standard footswitch, or Korg's special half-damper pedal, the optional DS-1H.

The DS-1H is a continuous pedal designed specifically for piano-style damper control, with the look and feel of an acoustic piano's sustain pedal. It allows more subtle control of the damper than a simple switch; the further down you press the pedal, the more that the sound sustains. For details, please see "Half-Damper Pedal and Release Time" on page 26 of the Parameter Guide.

You can also connect a simple footswitch, which will work as a standard on/off damper pedal.

In order to ensure that the pedal functions correctly, please adjust the switch polarity (see "Damper Polarity" on page 371 of the Parameter Guide) and the half-damper sensitivity (see "Half Damper Calibration" on page 383 of the Parameter Guide).

##### ASSIGNABLE SWITCH jack

This lets you connect a simple on/off footswitch, such as the optional Korg PS-1. The footswitch can perform a wide variety of functions, such as modulating sounds and effects, tap tempo, sequencer start/stop, etc.

The switch's function is set in Global mode (on the Controller tab of the Controllers/Scales page), so that it always works the same regardless of the current Program, Combination, or Song. For details, please see "Specifying the function of the Assignable Switch and Assignable Pedal" on page 132.

##### ASSIGNABLE PEDAL jack

This lets you connect a continuous controller pedal, such as the Korg EXP-2 foot controller or Korg XVP-10 EXP/VOL pedal, to use as an assignable modulation source.

Like the ASSIGNABLE SWITCH, the pedal's function is set in Global mode. For details, please see "Specifying the function of the Assignable Switch and Assignable Pedal" on page 132.

## 5. S/P DIF IN & OUT

These jacks provide 24-bit optical S/P DIF input and output, for connecting to computer audio systems, digital mixers, MDs, etc.

Optical S/P DIF is sometimes called TOSLINK, and formally named (hold your breath!) IEC60958, EIAJ CP-1201. Make sure to use optical cables designed for digital audio.

Whenever you use digital audio connections, make sure that all connected systems are set so that there is one and only one word clock master. You can set the word clock for the M3 using the Global page **System Clock** parameter. For details, please see “System Clock” on page 359 of the Parameter Guide.

### OUT(MAIN) jack

This optical S/P DIF output carries a digital version of the main L/R outputs.

*Note:* That the VOLUME MAIN slider does not adjust the S/P DIF output level.

### IN jack

You can use this optical S/P DIF input for recording, sampling, and real-time mixing through the built-in effects.

It can be used simultaneously with the two analog inputs, if you like.

## 6. AUDIO INPUTS

You can use the audio inputs for sampling, and real-time mixing through the built-in effects.

### AUDIO INPUT 1, 2

These are unbalanced 1/4" phone jacks.

### LEVEL knobs

This adjusts the input level of the AUDIO INPUT 1, 2 jacks. After setting the MIC/LEVEL switch appropriately, use this knob to adjust the gain.

### MIC/LINE switches

These set the input's nominal signal level. Set these switches according to the type of device that you're connecting, and then use the LEVEL knobs (described below) to optimize the gain.

Use the **LINE** setting when connecting to mixers, computer audio systems, signal processors, or other synthesizers.

Use the **MIC** setting only when connecting a microphone.

## 7. AUDIO OUTPUTS

All of the analog audio outputs use unbalanced 1/4" phone jacks, referenced to a +4dBu signal level.

Connect these outputs to the input jacks of your amp or mixer. In addition to the L/MONO and R main stereo audio outputs, the M3 provides eight individual audio outputs.

The sound from each oscillator, drum, timbre/track, or insert effect can be freely routed to any output. Additionally, you can route the metronome sound to an individual output, to separate it from the stereo

mix. For details, please see “Routing effect settings” on page 155.

### (MAIN) L/MONO, R

These are the main stereo outputs; their volume is controlled by the VOLUME MAIN slider. All of the factory Programs and Combinations are programmed to play through these outputs.

When editing sounds, or when setting up a Song in Sequencer mode, you can access the main outputs by setting **Bus Select** to **L/R**.

If no cable is connected to the R output, L/MONO will carry a mono summation of the stereo signal. So, if you are connecting to a device which does not have stereo inputs (such as a simple keyboard amp), use the L/MONO output.

### (INDIVIDUAL) 1, 2, 3, 4

These 4 additional audio outputs let you isolate sounds, or audio inputs for recording or complex live sound setups.

These can be used as stereo or mono outputs, in any combination. You can also use the Global P0: Basic Setup– Audio page **L/R Bus Indiv. Out Assign** parameter to map the main stereo outputs to any of these output pairs, if you like.

Note that the individual outputs are not affected by the VOLUME MAIN slider.

## 8. Headphone jack

This stereo 1/4" headphone jack carries the same signal as the Main L/R outputs.

The headphone volume is controlled by the VOLUME MAIN slider.

## 9. EXB-FW option

If you install the optional EXB-FW in the M3, you'll be able to enjoy the following total recall control functionality from a host application in which the included M3 Plug-in Editor is running.

- Send and receive MIDI data to and from the DAW software
- Edit and set up the parameters of the M3's various modes
- Send and receive the M3's 2-in and 6-out channels of digital audio.

If the EXB-FW is installed in the M3, it will have the following specifications.

- Audio input/output: 24-bit, 48 kHz fixed, 2-in/6-out
- MIDI input/output: one port in/out (sixteen MIDI channels in/out)

⚠ Please note the following points.

- The two jacks have the same function. The connector to which your computer is not connected can be used as a daisy-chain connector for a FireWire device that can be recognized by your computer. (The M3 will not recognize this device.)
- The EXB-FW does not supply bus power.

For details on installing the EXB-FW into the M3, please see page 202.

## Bottom panel

### 10. TO KYBD connector

Use the included cable to connect the M3 to the keyboard assembly. For details, please see “Keyboard assembly Manual.”

### 11. EXB option cover

You’ll need to open or close this cover when installing the EXB-RADIAS, EXB-FW, or EXB-M256 separately sold options into the M3, or when replacing the calendar backup battery.

For details on installing, please see page 202.

## Objects in the display

The M3 uses Korg’s TouchView graphical user interface.

By touching on objects shown on the display, you can select pages, set parameter values, rename programs and combinations, write data, and perform many other operations.

⚠ If the X-Y MODE switch is on, you won’t be able to select parameters in the display. Turn this switch off when you want to modify the settings.

*Note:* References in the M3’s manual to the “... button” or “... tab” please see objects shown on the display. References to the “... switch,” “... knob,” “... dial,” or “... slider” please see controls on the front or rear panel of the M3.

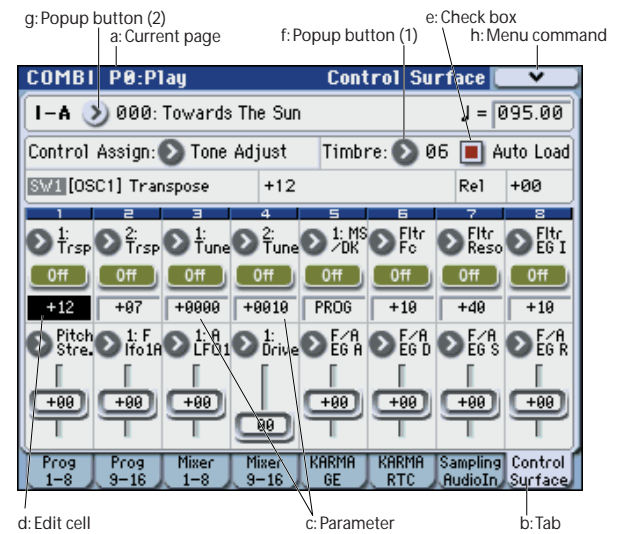

### a: Current page

This indicates the current page within the selected mode.

From the left, this area shows the mode name, page number: name, and tab name.

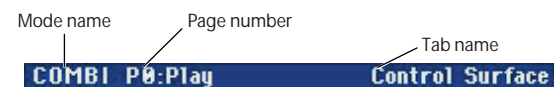

### b: Tab

Most pages are divided into two or more tabs.

### c: Parameters

The parameters for various settings are displayed in the display.

### d: Edit cell

When you touch a parameter on the display, the parameter or parameter value will usually be highlighted (displayed in inverse video). This is called the **edit cell**, and the highlighted item will be subject to editing.

For details on how to edit the value, please see “3. Selecting a parameter and editing the value” on page 23.

### e: Check box

Each time you press a check box, it alternates between the checked (red) and unchecked states.

The parameter will be active if it is checked, and inactive if it is unchecked.

### f: Popup button (1)

When this button is pressed, a popup menu will appear, showing the parameter values that are available for selection.

To enter the parameter value, press the desired value in the popup menu.

When a popup menu is displayed, using a VALUE controller (see page 12) will close the popup menu. If the popup menu is unlocked (see "Pin"), it will close if you touch a location outside the popup menu. The menu will close when you press the EXIT switch, regardless of whether it is locked or unlocked.

#### \* Popup menu

##### Pin

This switches the popup menu display between locked and unlocked.

When locked, the pin will be shown closed, and the popup menu will remain displayed even after you press a parameter value. When unlocked, the pin will be shown opened, and the popup menu will close immediately when you press a parameter value.

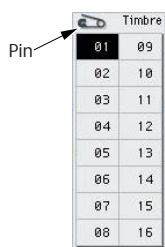

### g: Popup button (2)

When you press this button, a tabbed popup menu will appear, allowing you to perform the following selections.

- "Bank/Program Select," "Bank/Combination Select": Select programs or combinations by bank
- "Multisample Select": Select a multisample for a program oscillator by category
- "Effect Select": Select effects by category
- "Drumsample Select": Select drumkit ROM samples by category
- Select a KARMA GE

To close a tabbed menu, press the OK button or Cancel button.

#### Scroll bar

Use this when you wish to see parameter values that extend beyond what can be shown on the display at one time.

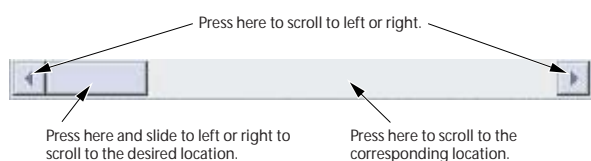

### Category button

When you press this button, a tabbed popup menu will appear, allowing you to perform the following selections.

- "Category/Program Select," "Category/Combination Select"
- Category/GE Select

Press the OK or Cancel buttons to close the tabbed category select popup menu.

The Jump to Sub button will display a sub-category selection menu.

### h: Menu command button

#### \* Menu

When this button is pressed, a list of menu commands will appear.

The menu commands that appear will differ depending on the currently selected page.

You can also select up to ten menu commands by holding down the ENTER switch and pressing a numeric key 0-9. The menu will close when you press the display at a location other than the menu, or when you press the EXIT switch.

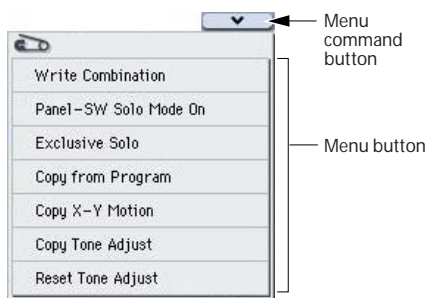

#### \* Dialog box

The dialog box that appears will depend on the currently selected menu command.

When selecting a program or combination number in a dialog box, use the VALUE controllers (see page 12) to input the number.

To execute, press the OK button. To cancel without executing, press the Cancel button. (The operation will occur when you press and release the button.) The dialog box will close. The EXIT switch corresponds to the Cancel button, Done button, and Exit button.

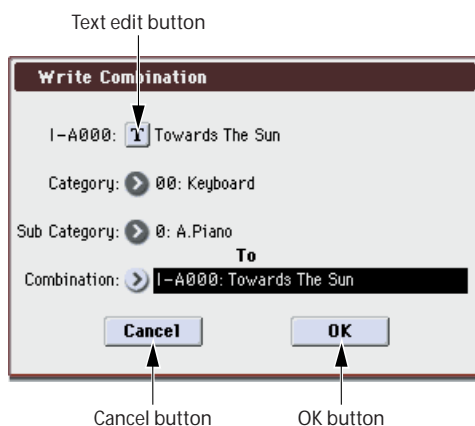

**\* Text edit button**

When you press this button, the text edit dialog box appears for changing the names of Programs, Combinations, Songs, etc. For details, please see “Editing names” on page 197.

**j: Radio buttons**

Press a radio button to select one value from two or more choices.

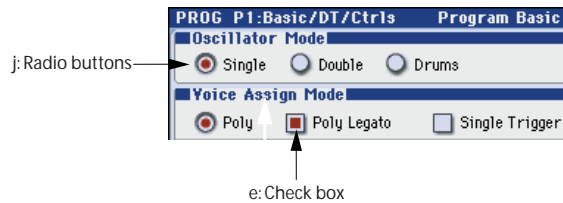



**k: Other objects**

To modify the parameter value of an object shaped like a slider or knob, first touch the object, and then use the VALUE controllers to modify the value. There are also buttons which execute an operation when they are pressed and released, such as Done, Copy, and Insert (similar to the OK and Cancel buttons explained under “\* Dialog box,” above).

**Toggle buttons**

This type of button will change its function or switch on/off each time it is pressed.

-  Play/Rec/Mute button in Sequencer mode
-  Solo On/Off button in Sequencer mode
-  On/Off button for Effect

## Basic Information

### About the M3's modes

The M3 has numerous functions that let you play and edit programs or combinations, record and play back sequence data, edit samples, and manage media. These functions are grouped into "modes." The M3 has six modes.

#### Program mode

Programs are the basic sounds of M3.

In Program mode, you can:

- Select and play Programs
- You can use a maximum of one KARMA module to generate phrases.
- You can play back Drum Track patterns while you perform using a Program.
- Sample and resample  
For example, you can sample an external audio source while listening to a performance generated by the KARMA function, or you can play a Program and resample your performance.
- Edit Programs  
Make detailed settings for oscillators, filters, amps, EGs, LFOs, effects, KARMA, X-Y control, etc.

EDS (Enhanced Definition Synthesis) sound generation system:

The oscillators can use the following multisamples.

- Preloaded (256 Mbyte): 1,032 multisamples (including seven stereo)
- RAM (64 Mbyte: if the optional EXB-M256 is installed, a total of 320 Mbytes. However, 512 bytes are used by the system.): RAM multisamples sampled by the M3 or loaded in Media mode
- Create drum programs using drum kits (as created in Global mode)

When the optional EXB-RADIUS is installed:

The MMT (Multiple Modeling Technology) sound generation system will be available for performance and editing.

#### Combination mode

Combinations are sets of up to 16 programs that can be played simultaneously, letting you create sounds more complex than a single Program. In Combination mode, you can:

- Select and play Combinations
- Use a maximum of four KARMA modules to generate phrases.
- Use one timbre to play back Drum Track patterns.
- Use M3 as a 16-track multitimbral tone generator
- Sample or resample  
For example you can sample an external audio source while listening to the performance of the KARMA, or resample a performance you play using a combination.

- Edit Combinations  
Assign Programs to each of the 16 Timbres, each with separate volume, pan, EQ, and keyboard and velocity zones; make settings for effects, X-Y control, and KARMA.

#### Sequencer mode

Sequencer mode lets you record, play back, and edit MIDI tracks. You can:

- Select and play Songs  
Assign Programs to each of the 16 MIDI Tracks, each with separate volume, pan, EQ, and keyboard and velocity zones; make settings for effects, X-Y control, and KARMA; edit MIDI data
- Record up to sixteen MIDI tracks simultaneously
- Control and play up to four KARMA modules
- Sample or resample  
You can sample an external audio input source while playing a song, and use In-Track Sampling to automatically create a note event that triggers the sample at the same time as it was recorded. You can also resample an entire song, and then use Media mode to create an audio CD.
- Use M3 as a 16-track multitimbral tone generator
- Record patterns and assign them to individual keys, using RPPR (Realtime Pattern Play/Recording)
- Create user Drum Track patterns.

#### Sampling mode

Sampling mode lets you record and edit user samples and multisamples. For example, you can:

- Sample external audio sources (i.e., record samples), including sampling through effects
- Edit waveform data you sampled or loaded in from media, and set loop points etc.
- Create and edit multisamples, which consist of one or more samples spread out across the keyboard
- Quickly convert multisamples into Programs
- Directly sample or rip digital audio from an audio CD in a USB CD-R/RW drive (commercially available). You can also play back audio CDs.



### Global mode

Global mode lets you make overall settings for the entire M3, and edit drum kits. For instance, you can:

- Make settings that affect the entire M3, such as master tune and global MIDI channel
- Create user drum kits, and user scales
- Create drum kits using ROM, or RAM drumsamples
- Rename program, combination, and KARMA GE categories
- Set the function of the assignable pedals and assignable switches
- Transmit MIDI System Exclusive data dumps

- Load Korg format, AKAI, SoundFont 2.0, AIFF, and WAVE samples, and export RAM samples in AIFF or WAVE formats
- Export and import sequences to and from SMF (Standard MIDI Files)
- You can use the Data Filer function to save or load MIDI System Exclusive data
- Edit WAVE files.
- Place the WAVE files in the desired song order, and use a USB CD-R/RW drive (commercially available) to create an audio CD. Create and play back audio CDs

### Media mode

You can save or load data using a USB 2.0 compatible storage device. You can:

- Save and load Programs, Combinations, Songs, Samples, and Global setup data
- Format USB storage media, copy and rename files, etc.

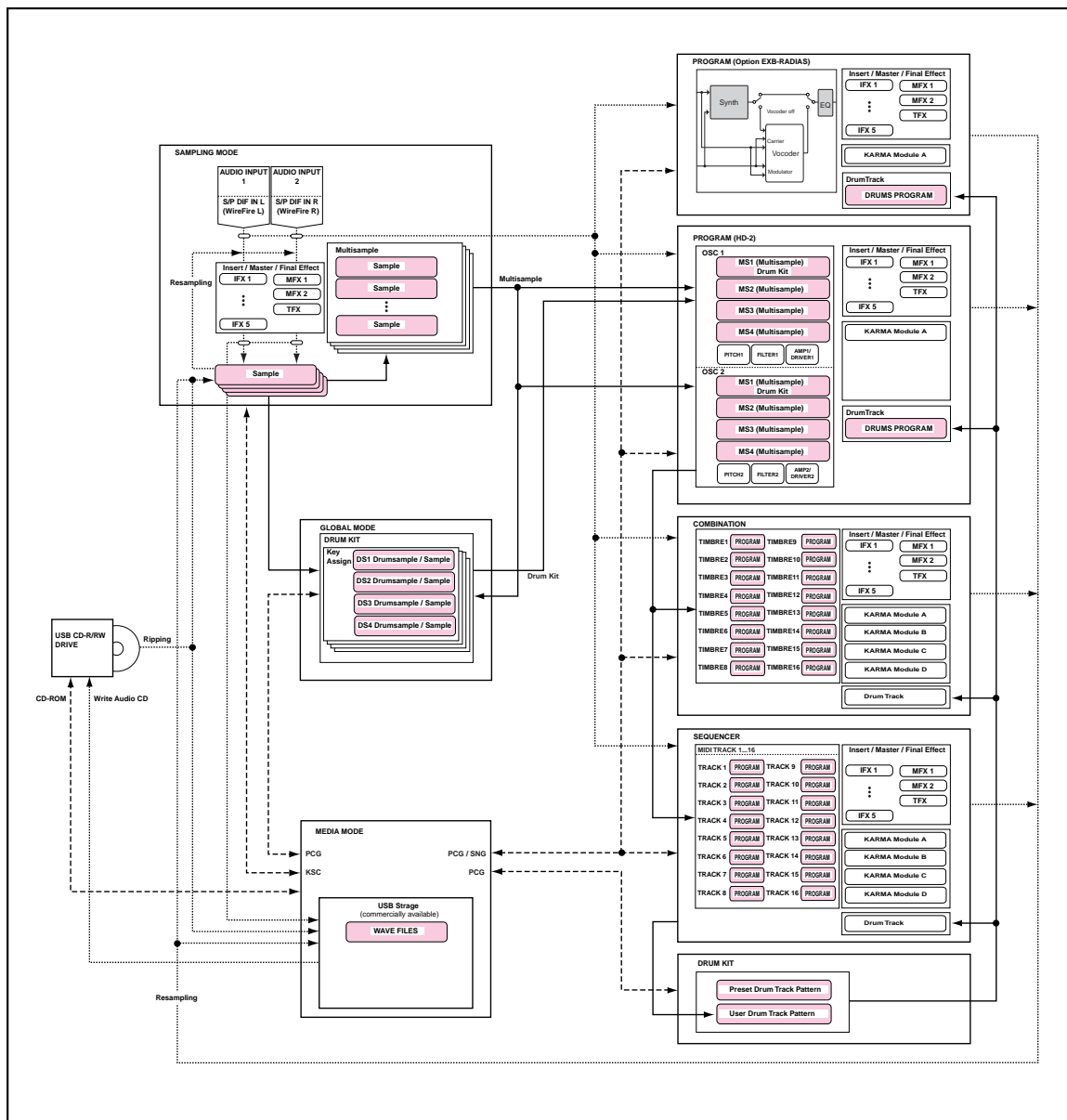

## Basic operations

After you've turned on the M3, here's how to perform basic operations such as selecting modes and pages.

### 1. Selecting modes

- In order to use a particular function on the M3, you must first select the appropriate mode.

Press one of the front panel mode switches to enter the corresponding mode.

COMBI switch: Combination mode  
 PROG switch: Program mode  
 SEQ switch: Sequencer mode  
 SAMPLING switch: Sampling mode  
 GLOBAL switch: Global mode  
 MEDIA switch: Media mode

### 2. Selecting pages and tabs

Each mode has a large number of parameters, which are grouped into pages. These are further subdivided by tabs into up to eight tab pages.

- Make sure that the desired mode is selected.  
 For details on selecting a mode, see "1. Selecting modes," above.  
 In this explanation we'll use Combination mode as an example.  
 Press the COMBI switch.

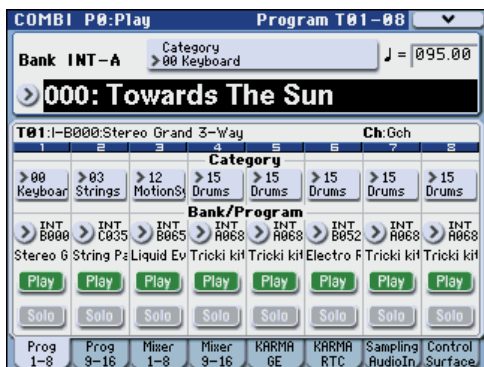

*Note:* The Combi P0: Play page will appear. (This is shown in the upper left of the display.)

In Combination, Program, or Sequencer modes, you will normally perform in this P0: Play page. You can also make simple adjustments (edits) to the sound while you're in this page. To make more detailed adjustments, use page 1 (Combi P1: DT/XY/Ctrls, etc.) and following.

#### Selecting a page

##### Using Page Select to move

In Combination, Program, Global, and Sequencer modes, you can press the PAGE SELECT switch to view a list of the pages that make up that mode.

##### 1. Press the PAGE SELECT switch.

The page select menu will appear.

The page in which you were when you pressed the PAGE SELECT switch will be highlighted as an indication.

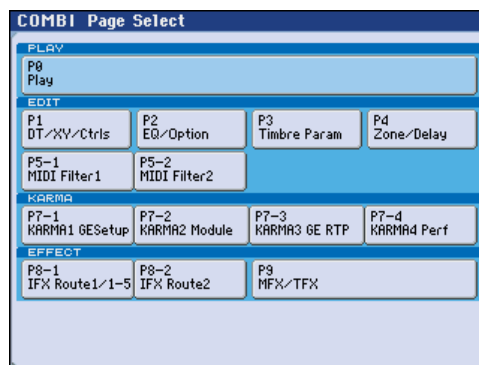

##### 2. Press the page that you want to view.

As an example here, try selecting "P4 Zone/Delay." The P4: Zone/Delay- Key Z T01-08 page will appear.

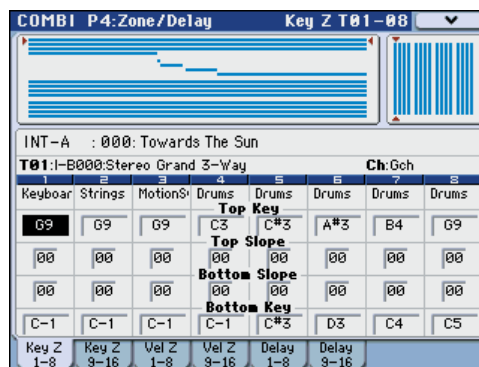

*Note:* The page that appears will be the page of the tab you selected most recently.

##### Using the PAGE SELECT switch + numeric keys 0-9 switches to move

- Hold down the PAGE SELECT switch and use numeric keys 0-9 to specify the page number you want to view.

The specified page number will appear. The page that appears will be the page of the tab you selected most recently.

*Note:* In pages consisting of multiple pages such as P5-1, P5-2, P7-1 - P7-4, P8-1, and P8-2, the first page (P5-1, P7-1, or P8-1) will be selected.

##### Using the EXIT switch to move to page 0

- You can press the EXIT switch to return to page 0 from any page.

#### Selecting tabs

- You can access tabbed pages by pressing the tabs shown in the bottom line of the display.

This example shows the Program T01-08 page through Mixer T01-08 page of Combi P0: Play.

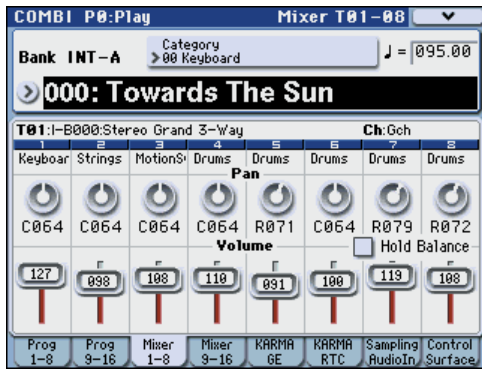

### 3. Selecting a parameter and editing the value

#### 1. Press the parameter that you want to edit.

It will be highlighted. (This is called the “edit cell.”)

#### 2. To modify the parameter value in the edit cell, use the VALUE controllers (VALUE dial, $\Delta/\nabla$ switches, numeric keys 0–9, – switch, (.) switch, and ENTER switch).

*Note:* The way in which the value will change depends on the type of parameter or object.

For example in the case of a check box object, you can switch the value by pressing that object. You can use the PROG SELECT switches to specify the bank for programs etc., or hold down the ENTER switch and press a note on the keyboard to enter a note or velocity value (“keyboard input”).

#### 3. For parameters that are mapped to the control surface, you can use the MIX PLAY/MUTE (SOLO) switches or MIX VOLUMES sliders to edit the values.

*Note:* You can use the COMPARE switch to compare the sound you’re editing with the original unedited sound.

### VALUE controllers

#### VALUE dial

Use this dial to edit the selected parameter’s value. This control is convenient when you want to scroll through a very long list of selections.

#### VALUE slider

This slider increases or decreases the value of the selected parameter in the same way as the VALUE dial. This slider can also be used as a control source for modulation. Use this when you want to change a value by a large amount.

#### $\Delta/\nabla$ switches

Use these when you wish to make small changes in the value.

#### Numeric keys 0–9, ENTER switch, – switch, (.) switch

These switches are convenient when you know the exact value that you want to enter. Use the 0–9, –, and decimal (.) switches to enter the value, and then press the ENTER switch to confirm the entry.

The – switch inverts the sign (+/–) of the parameter value; the decimal (.) switch inserts a decimal, for entering fractional values.

By holding down the ENTER switch and playing a note on the keyboard, you can enter the following value.

#### ENTER switch + keyboard (note name or velocity input)

You can use the M3’s keyboard to specify the value of a parameter when you need to enter a note name or a velocity value. Hold down the ENTER switch, and play the note that you want to enter; the corresponding note name or velocity value will be entered.

This function is unavailable while a menu command is open, since the ENTER switch will be functioning as the OK button.

When the Global P5: Drum Kit page is shown, you can hold down the ENTER switch and play a note to access the settings assigned to that note. (If a velocity-related parameter is selected, this action will enter the velocity value.)

### Other

#### BANK SELECT I–A, I–B, I–C, I–D, I–E, I–F, I–G, U–A, U–B, U–C, U–D, U–E, U–F, U–G switches

Use these switches to change banks when selecting Programs or Combinations. The LEDs in the switches light up to show the current bank.

In Program mode, these switches select the Program bank.

In Combination mode, these switches have two functions:

- When you’re selecting Combinations, they choose the Combination bank.
- When you’re assigning a Program to a timbre within the Combination, they select the Program bank.

In Sequencer mode, when a track’s Program name is selected, these switches change the Program bank.

#### TEMPO knob, TAP TEMPO switch

You can set the tempo by turning the TEMPO knob or by repeatedly pressing the TAP TEMPO switch.

#### Control surface

For details on using the control surface to edit values, please see page 42.

#### COMPARE switch

Use this when you wish to compare the edits you have made to a program or combination’s sound with the un-edited original (i.e., the sound that is written into memory).

When editing a program or combination, press this switch. The LED will light, and the last-written settings for that program number or combination number will be recalled. When you press the COMPARE switch once again, the LED will go dark and you will return to the settings that you were editing.

If you edit the settings that are recalled by pressing the COMPARE switch (i.e., the settings that are written into memory), the LED will go dark, and it will not be

possible to return to the previous edits by pressing the COMPARE switch again.

In Sequencer mode, you can use the COMPARE switch to make “before and after” comparisons immediately after using realtime recording or step recording to record a song, or after performing a track edit operation.

For example, this can be used effectively when realtime-recording a track for a song.

1. **Realtime-record a MIDI track. (Take 1)**
2. **Once again, realtime-record on the same track. (Take 2)**
3. **Press the COMPARE switch. The LED will light, and take 1 will be recalled.**
4. **Press the COMPARE switch once again. The LED will go dark, and take 2 will be recalled.**
5. **If at step 3 you once again realtime-record on the same track (take 3), the object of the Compare function will now be take 1.**

If at step 4 you once again realtime-record on the same track (take 3), the object of the Compare function will be take 2.

In this way, the Compare function lets you recall the previous recording or the previous state of event editing.

⚠ The Compare function does not work in Global mode, with the exception of Sampling, Media editing.

## 4. Selecting and executing a menu commands

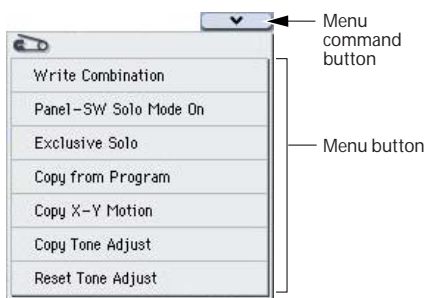

The utility functions provide commands that are specific to each page, such Write (save) or Copy. The available utility functions will depend on the page you select.

For example, the utility functions in Program mode let you write (save) the settings, or let you perform convenient editing operations such as copying settings between oscillators or effects, or a Sync function that lets you edit two EGs together.

1. **In the upper right of the display, press the ▾ button.**

The menu command will appear.

2. **Select a menu command by pressing it with your finger.**

A dialog box for the selected menu command will appear.

Check-type commands will not display a dialog box; their status will be switches, and the list will close.

By holding down the ENTER switch and pressing a numeric key 0–9 you can access the dialog box for the first ten utility functions without going through the menu.

- If you want to close the list without selecting a command, press the display somewhere other than the list, or press the EXIT switch.
3. **For a parameter in a dialog box, select it by pressing it with your finger, and use the VALUE controllers (e.g., VALUE dial or  $\Delta/\nabla$  switches) to enter its value.**

When selecting a program or combination number in a dialog box, you can also use the BANK SELECT switch to enter the bank as an alternative to using the VALUE controllers.

4. **To execute, press the OK button or the ENTER switch.**

If you decide not to execute, press the Cancel button or the EXIT switch.

The dialog box will close.

## 5. Writing/saving

After you edit, you should write or save your changes as necessary.

For example if you've edited a program, your changed will be lost if you select another program or turn off the power. The same applies to a combination.

Settings you edit in Global mode will be remembered as long as the power is on, but your changes will be lost when you turn off the power.

For details on the Write operations, see the following pages.

- Programs → p.50
- Combinations → p.69
- Effect presets → PG p.118
- Global settings (pages 0–4) → p.129
- Drum kits → p.138
- User Drum Track patterns → p.195  
Preset/user Drum Track patterns are saved in internal memory even when the power is turned off. Patterns you create in Sequencer mode can be converted into user Drum Track patterns and saved in internal memory.
- User template songs → PG p.272  
Preset/user template songs are saved in internal memory even when the power is turned off. Track settings and effect settings of a song you create can be saved in internal memory by the menu command **Save Template Song**.
- For details on writing to internal memory → p.140

Refer to the following pages for more about saving.

- Saving to media (Media-Save) → p.152

*Note:* On the M3, the action of writing to internal memory is called “Write,” and the action of saving to an external USB storage device is called “Save.”

# Setup

## Turning the power on/off

### Connecting the AC cable

1. Make sure that the M3's power switch is in the **STANDBY (outward) position**.
2. Connect the included power cable to the power connector on the M3's rear panel.
3. Plug the power cable into an AC outlet.

### Turning the power on

1. Lower the M3's **VOLUME MAIN** slider.

If you have connected powered monitor speakers or a stereo amp, turn down the volume of these devices.

2. Press the rear panel Power switch to turn on the power.

The display will show the model name, software version. (The following graphic shows the factory-set display. The version number is subject to change without notice.)

3. Turn on your powered monitors or stereo amp.
4. Raise the M3's **VOLUME MAIN** slider to an appropriate position, and adjust the volume of your powered monitor speakers or stereo amp.

*Note:* The state of M3 when the power is turned on will depend on the setting of **Power On Mode**. (See page 130)



### Turning the power off

1. After you've finished editing, be sure to write (save) your changes.

If you edit a program and then select a different program or turn off the power, the changes you made will be lost. The same is true for a combination.

The settings you edit in Sequencer mode and Global mode are remembered as long as the power is on, but will be lost when you turn off the power.

1. Lower the M3's **VOLUME MAIN** slider.

Also turn the volume of your powered monitor speakers or stereo amp down to zero.

2. Turn off the power of your powered monitor or stereo amp.

3. Press the rear panel Power switch to turn off the power.

1. Never turn off the power while data is being written into internal memory.

If the power is turned off while processing is being performed, memory write operations will not be completed correctly. If this occurs, M3 will automatically initialize its internal memory so that it will operate correctly. This is not a malfunction. While data is being written, the display will indicate "Now writing into internal memory." Data is written into internal memory by the following operations.

- When writing Program, Combination, Global Setting, Drum Kits, RADIUS Formant Motion data, or converting to a user Drum Track pattern (update)
- When loading Program, Combination, Global Setting, Drum Kit, or RADIUS Formant Motion preload data
- When receiving a MIDI data dump of Program, Combination, Global Setting, Drum Kit, RADIUS Formant Motion, or user Drum Track pattern data

# Connections

- ⚠ Connections must be made with the power turned off. Please be aware that careless operation may damage your speaker system or cause malfunctions.
- ⚠ You can tilt the M3-M (sound module) upward for use if desired. For the procedure, refer to the included manual.

The following illustration is an example of connections. Be sure you use the correct type of cable for each connection.

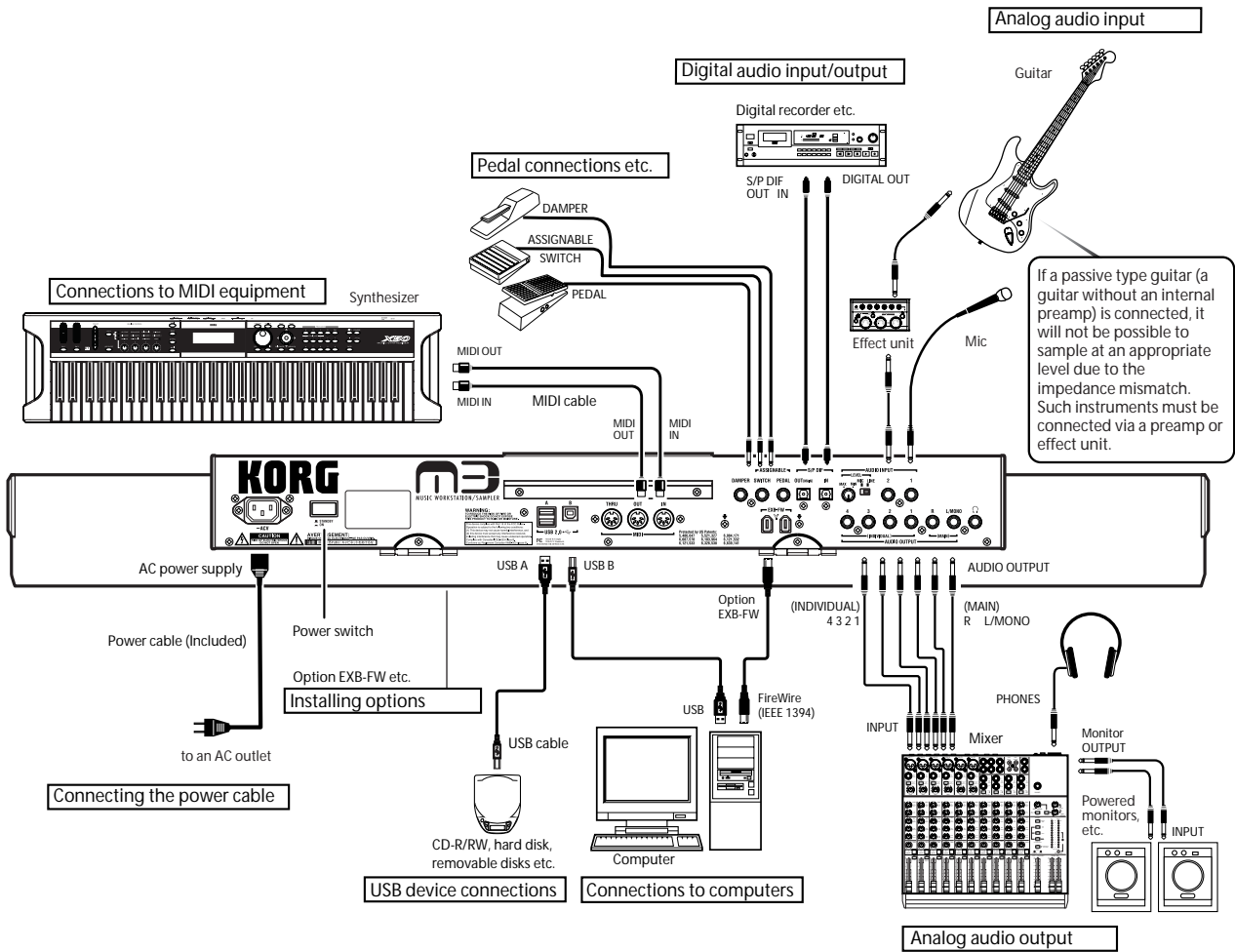



## Connecting audio equipment

### Analog audio output

Here's how to connect the M3 to your analog amp or mixer.

- ⚠ If you've connected a stereo audio amp, be aware that playing at high volume may damage your speaker system. Be careful not to raise the volume excessively.

### AUDIO OUTPUT (MAIN) L/MONO and R

These are the main outputs, accessed by setting **Bus Select** to L/R. All of the factory sounds use these outputs, and the Master and Total Effect are always routed here as well.

1. **Connect the AUDIO OUTPUT (MAIN) L/MONO and R outputs to the inputs of your powered monitor or mixer.**

If you're using M3 in stereo, use both the (MAIN) L/MONO and R jacks. If you're using M3 in mono, use only the (MAIN) L/MONO jack.

If you're playing back through a stereo audio amp or a radio cassette recorder that has an external input jack, connect the M3 to the jack(s) labeled LINE IN, AUX IN, or external input. (Use an adapter cable with the appropriate type of plug.)

The VOLUME MAIN slider affects only the main stereo outputs and the headphones; it does not affect the individual outputs, or the S/P DIF output.

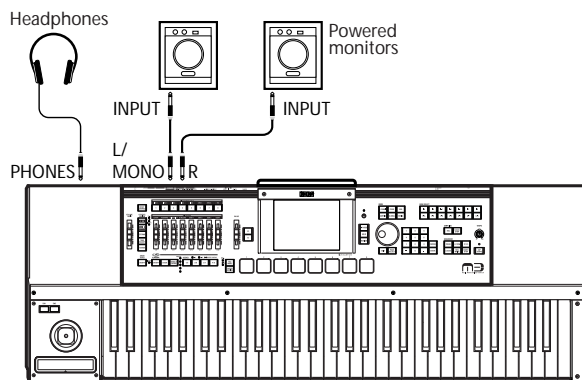

### AUDIO OUTPUT (INDIVIDUAL) 1-4

These are 4 additional analog outputs, which can be used as individual mono outputs, stereo pairs, or any combination of the two. Almost any signal source can be routed to these outputs, including:

- Each note in a Drum Kit
- Insert Effect outputs
- Each Program in a Combination or Song
- Audio inputs

You can use these to isolate or group together sounds for recording, or for complex live performance setups.

1. **Connect the (INDIVIDUAL) 1-4 outputs to the your amp or mixer inputs.**

2. **Use the Bus Select parameters to send the desired sounds, audio tracks, inputs, or effects to the individual outputs, as either mono (1...4) or stereo (1/2, 3/4) signals.**

If the signal is going through one or more insert effects, the output is set at the last IFX in the chain, via the **Bus Select** parameter on the P8- Insert FX Setup page.

If a Program, Timbre, or Track is not going through any insert effects, the output is set using the **Bus Select** parameters on the P8-1 or 8-2 Routing page.

To assign audio inputs directly to outputs, use **Bus Select** parameters in the P0- Audio Input (Sampling) page.

In Global mode, the Audio page **L/R Bus Indiv. Assign** setting lets you mirror the MAIN stereo L/R output on any pair of individual outputs. You can use this to create a private monitoring setup in live and studio environments. For details, please see "L/R Bus Indiv. Assign (Assign to L/R and Indiv.Out)" on page 362 of the Parameter Guide.

*Note:* You can't use the VOLUME MAIN slider to adjust the volume of the individual outputs.

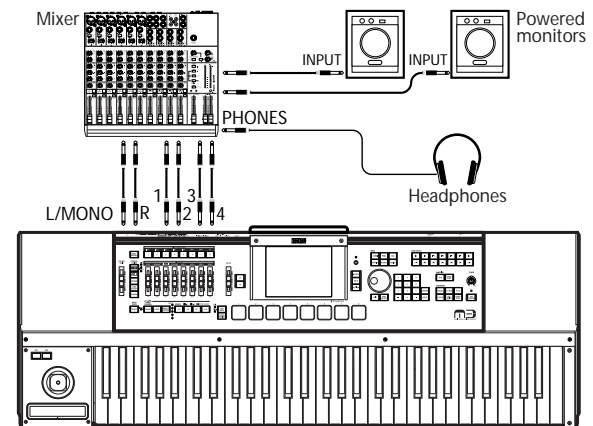

### Headphones

1. **If you're using headphones, connect them to the M3's headphone jack.**
2. **Use the VOLUME MAIN slider to adjust the volume of the headphones. The M3's headphone jack outputs the same signal as the AUDIO OUTPUT (MAIN) L/MONO and R jacks.**

*Note:* To monitor the (INDIVIDUAL OUTPUT) 1-4 signals, use an external mixer.

---

## Analog audio input

Here's how to input external analog audio sources into the M3 so that they can be sampled, or processed through the internal effects.

### AUDIO INPUT 1, 2

These two inputs use unbalanced 1/4" phone jacks. They also include preamps with adjustable gain.

You can use these for:

1. **Connect your mics or the output jacks of your external audio sources to the INPUT 1 and 2 jacks.**

These are unbalanced 1/4" phone jacks.

2. **Set the MIC/LINE switch as appropriate for the device you've connected, and use the LEVEL knob to adjust the gain.**

Use the LINE setting if you're inputting from a mixer, an audio system, or another synthesizer.

Choose the MIC setting (switch in the outward position) if you've connected a mic.

3. **Adjust the output level on your external device.**
4. **After turning on the power, use the Sampling/Audio In page to set up the volume, pan, bus routing, and send levels for the inputs, as desired.**

For details, please see "Bus Select" on page 10, and page 361 of the Parameter Guide.

*Note:* Guitars with active pickups can be connected directly to any of the inputs. Guitars with passive pickups (i.e., guitars that do not have an internal preamp) can be used with inputs 1 and 2, but the impedance mismatch will cause both a change in tone and a reduction in volume. For best results, route such guitars through a pre-amp or effects unit before connecting them.

---

## Digital audio output

### S/P DIF OUT (MAIN)

The same signal as the M3's AUDIO OUTPUT (MAIN) L/MONO and R jacks can be digitally output to an audio system, mixer, or MTR, or other device that can accept a sampling rate of 48 kHz.

1. **Use an optical cable to connect the S/P DIF OUT (MAIN) jack to the external optical digital input jack of your device.**

This will output the same audio signal as the AUDIO OUTPUT (MAIN) L/MONO and R jacks.

*Note:* You can't use the VOLUME MAIN slider to adjust the volume of the digital output.

2. **Make the appropriate "System Clock" setting.**

 When two or more digital audio devices are connected, all of them must be synchronized to a single clock; one device must be the master, and the other devices must be slaves.

For example if you've connected two M3 units via their S/P DIF jacks (IN and OUT), you should set **System Clock** to Internal on one unit and to S/P DIF on the other unit. If you've connected a consumer digital audio device via S/P DIF (IN and OUT), set the M3's **System Clock** to S/P DIF.

Set **System Clock** in the Global P0: Basic Setup-System Preference page.

---

## Digital audio input

### S/P DIF IN

An audio system, digital mixer, MTR that can output audio at a sampling rate of 48 kHz can be input to the M3's L and R channels, and sampled to the hard disk or routed through the internal effects and sent to the OUTPUT jacks.

1. **Use an optical cable to connect the external optical digital output of your DAT or other device to the S/P DIF IN jack of the M3.**
2. **Set System Clock (Global P0: Basic Setup-System Preference page) to S/P DIF.**

For details, please see "System Clock" on page 359 of the Parameter Guide.

3. **After turning on the power, use the Sampling/Audio In page to set up the volume, pan, bus routing, and send levels for the inputs, as desired.**

For details, please see "Bus Select" on page 10, and page 361 of the Parameter Guide.

You can use the S/P DIF inputs simultaneously with the four analog inputs.

## Connecting a damper pedal, foot switch, or foot pedal

By connecting an optional damper pedal, foot switch, or foot pedal, you can control even more functions and effects.

You can use the damper pedal to apply a damper effect while you play.

You can use the foot switch to turn the sostenuto or soft pedal effect on/off, to turn the KARMA function on/off, to switch programs or combinations, or to control tap tempo.

You can use the foot pedal to control volume or modulation.

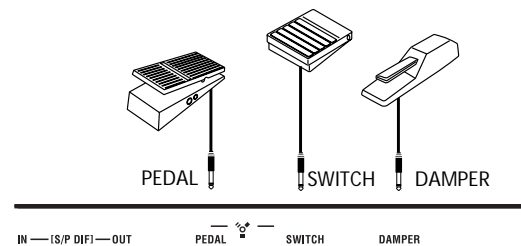

## Connecting a damper pedal

This pedal can provide a damper effect as you play. This instrument also supports half-damping. Here's how to connect an optional Korg DS-1H damper pedal to the DAMPER jack and use it to control the half-damper effect.

1. **Connect an optional DS-1H damper pedal to the DAMPER jack.**

You'll be able to control the half-damper effect if you've connected the DS-1H. If you've connected a different switch-type pedal, it will function as a damper switch.

2. **After you turn on the power, set the switch polarity and adjust the half-damper response to ensure that the half-damper pedal works correctly. (See PG page 371, and page 383)**

## Connecting a foot switch

If you connect an on/off-type foot switch such as the Korg PS-1 pedal switch to the ASSIGNABLE SWITCH jack, you can use it to turn the sostenuto or soft pedal effect on/off, to control tap tempo, or to apply modulation to a sounds or an effect.

This switch will always function in the same way regardless of the Program, Combination, or Song you've selected. You can assign the function in the Global mode.

1. **Connect a foot switch such as the optional PS-1 to the ASSIGNABLE SWITCH jack.**
2. **After turning the power on, use Global P2: Controllers— Foot Controllers page “Foot Switch Assign” and “Foot Switch Polarity” to assign the function controlled by the foot switch and to specify the polarity. (See page 39, and page 132)**

## Connecting a foot pedal

If you connect a optional EXP-2 foot controller or XVP-10 expression/volume pedal to the ASSIGNABLE PEDAL jack, you can use it to apply modulation to sounds or effects, or to adjust the overall volume.

This pedal will always function in the same way regardless of the Program, Combination, or Song you've selected. You can assign the function in the Global mode.

1. **Connect an optional XVP-10 or EXP-2 to the ASSIGNABLE PEDAL jacks.**
2. **After turning the power on, use Global P2: Controllers— Foot Controllers page “Foot Pedal Assign” to assign the function controlled by the foot pedal. (See page 133)**

## Connecting a computer

The M3 provides USB connectors as standard equipment. By connecting the M3 to your computer via USB, you can use it as a controller and MIDI sound module for your DAW software.

By using the dedicated editor, you can edit the M3 from your computer as though it were a software plug-in. (Audio data is not transferred via the USB connector.)

If you install the optional EXB-FW, you'll be able to send and receive MIDI and audio data (2-in/6-out) within the dedicated editor via the FireWire connector.

You can connect the M3 to your computer in the following three ways.

- Connect the M3's USB B connector to a USB port of your computer.
- Connect the M3's MIDI connectors to your computer via a commercially available MIDI interface.
- Install the optional EXB-FW, and connect the M3's FireWire connector to a FireWire port of your computer.

## USB connection and setup

If you connect the M3's USB B connector to your computer, you'll be able to send and receive note data and other performance information and sound settings between your computer and the M3 as MIDI messages.

*Note:* The USB B connector of the M3 is only able to transmit and receive MIDI data.

-  Before you connect the M3 to your computer via USB, you must install the KORG USB-MIDI driver in your computer. The driver must be installed for each USB port you use. If you connect the M3 to a USB port other than the one you used when installing the KORG USB-MIDI driver, you'll need to install the driver again. For details, please see "Installing the software" on page 34.

- 1. Using a USB cable, connect the USB B connector of the M3 to the USB connector of your computer.**

*Connection for the M3-61/73/88*

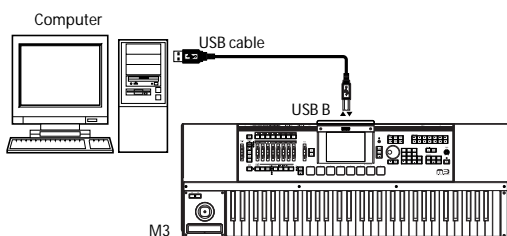

*Connection for the M3-M*

If you're using an external MIDI keyboard to control the M3-M, make connections as follows.

If you're using the M3 Editor, make connections as shown in the following illustration.

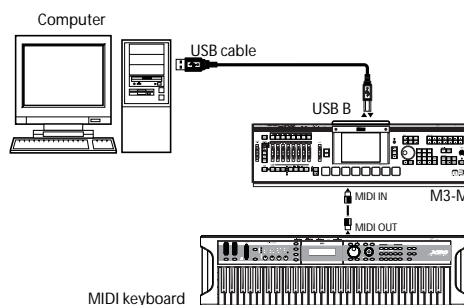

If you're using the M3 Plug-In Editor or a DAW, you can connect your MIDI keyboard via your computer as shown in the following illustration, instead of using the connections shown in the illustration above. (If you connect to your computer via MIDI, you'll need a commercially available MIDI interface.)

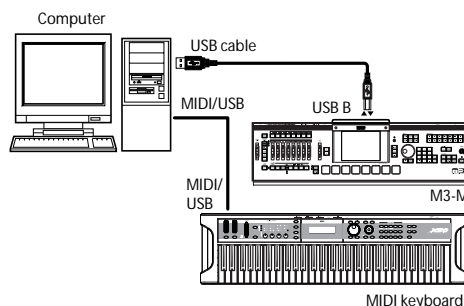

- 2. Make the necessary settings in the M3's Global mode.**

For details, please see "Global mode settings on the M3" on page 32.

- 3. Make the necessary settings on your computer.**

For details, please see "M3 Editor/Plug-In Editor Manual" (PDF).

## Using the M3 Editor/Plug-In Editor via a USB connection

Here are some examples of how to use the system with the M3 Editor/Plug-In Editor connected via USB.

If you want to mix the M3's audio signals with the audio signals sent from your host application via your audio interface, or with audio signals from another sound module, make connections as shown below.

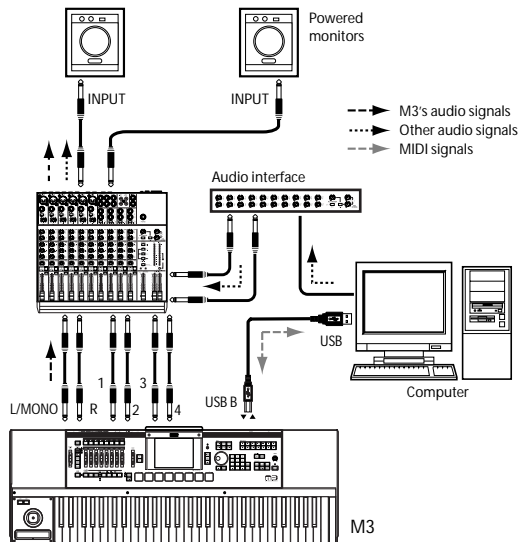

If you want to apply a plug-in effect to the M3's audio signals, or to control the M3's audio signals in your host application together with the audio data from the KORG Legacy Collection or other audio tracks, make connections as shown below. Make settings as appropriate for the host application you're using.

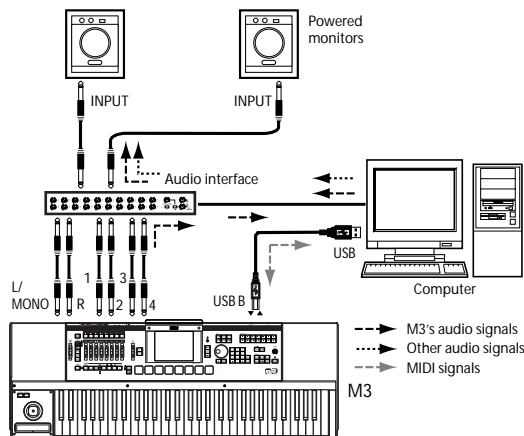

## Connecting your computer via the MIDI connectors

You can use a commercially available MIDI interface to connect the M3 to your computer.

1. Connect the M3's MIDI OUT connector and MIDI IN connector to the MIDI IN port and MIDI OUT port of your MIDI interface. For details, refer to the manual included with your MIDI interface.

Some USB-MIDI interfaces may be unable to transmit or receive the M3's MIDI exclusive messages.

### Connection for the M3-61/73/88

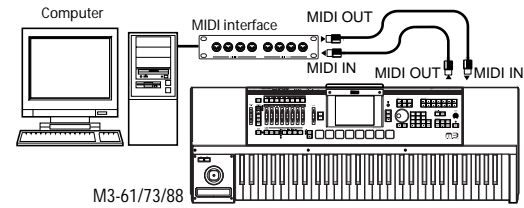

### Connection for the M3-M

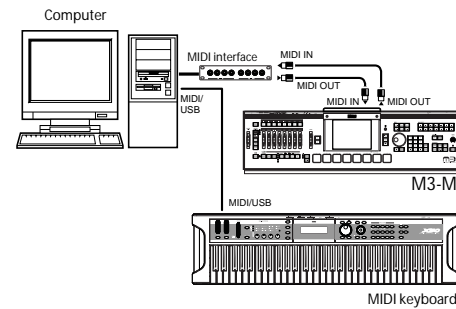

*Note:* If you're controlling the M3-M from a keyboard, connect your MIDI keyboard via a MIDI interface.

2. Make the necessary settings in the M3's Global mode.

For details, please see "Global mode settings on the M3" on page 32.

## Connection and setup for the optional EXB-FW

If you install the optional EXB-FW, you'll be able to exchange audio signals and MIDI messages between the M3 and your computer from a host application in which the included M3 Plug-In Editor is running.

Audio input/output: fixed at 24-bit 48 kHz, 2-in/6-out  
MIDI input/output: one port in/out (16 MIDI channels in/out)

For details on installing the optional EXB-FW into the M3, please see "Installing the EXB-FW" on page 205.

Please note the following points.

- The two connectors have the same function. The connector that's not connected to your computer can be used for a daisy-chain connection with a FireWire device that your computer can recognize. (The M3 will not recognize this device.) If the M3 is powered-off, the daisy-chained FireWire device cannot be detected from the connected computer.
- The EXB-FW does not supply bus power.
- Don't connect the EXB-FW to two computers simultaneously.
- Don't connect the EXB-FW to two M3 units simultaneously.
- The EXB-FW can handle MIDI and audio only within a host application in which M3 Plug-In Editor is running.
- In order to use the dedicated editor via FireWire, you must install the KORG FireWire-Audio/MIDI driver. For details, please see "Installing the software" on page 34.







## Connecting MIDI devices

By connecting the M3's MIDI connectors to an external MIDI device you can transfer sound settings and performance data such as note messages between your external MIDI device and the M3.

### About MIDI

**MIDI** stands for Musical Instrument Digital Interface, and is a world-wide standard for exchanging various types of musical data between electronic musical instruments and computers. When MIDI cables are used to connect two or more MIDI devices, performance data can be exchanged between the devices, even if they were made by different manufacturers.

## Controlling an external MIDI tone generator from M3

If you want to use the M3's keyboard, pads and other controllers, sequencer, and KARMA function to play or control an external MIDI sound module, use a MIDI cable to connect the M3's MIDI OUT connector to the MIDI IN connector of your external MIDI sound module.

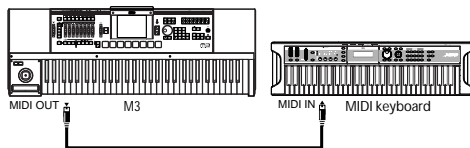

## Controlling M3's tone generator from an external MIDI device

When you wish to play or control the M3's tone generator from an external MIDI keyboard or sequencer etc., use a MIDI cable to connect the MIDI OUT connector of the external MIDI device to the MIDI IN connector of M3.

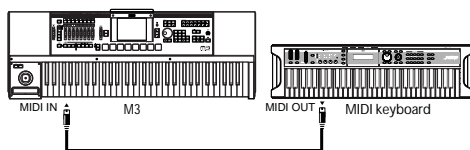

## Controlling two or more external MIDI tone generators from M3

You can also use a MIDI patch bay to control multiple MIDI devices.

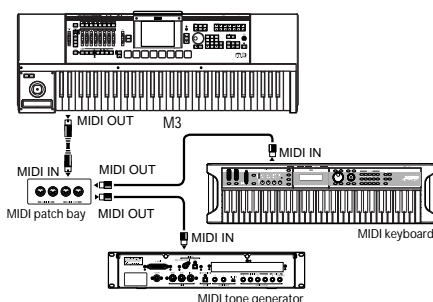

## Connecting a USB device (HDD, CD-R/RW, etc.)

You can connect a USB 2.0 compatible hard disk drive or other USB storage device to the M3's USB A connector, and use it to save or load M3 data such as PCG or SNG files or WAVE files.

If you connect a USB CD-R/RW drive, you'll be able to make an audio CD from songs you created on the M3 (and converted to WAV files).

To make the connections:

- Connect the M3's USB A connector to the USB connector of your USB device.

The maximum supported capacity depends upon the format of the USB device. With FAT16 format, the maximum capacity is 4 GB; with FAT32, the maximum is 2 Terabytes (2,000 GB).

1. Use a USB cable to connect your external USB device to one of the M3's USB A ports.

Standard USB cables have a different connector at each end. Plug the flat, rectangular connector into the M3, and plug the square-ish connector into the external USB storage device.

*Note:* If the device you are using does not support hot-plugging, make connections with the device powered-off, and then turn on the power of your device.

2. Execute the Media mode Utility menu command "Scan USB Device."

3. Use the Media mode Media Select screen to check the connection.

For more information, see "Loading & saving data, and creating CDs" on page 139.

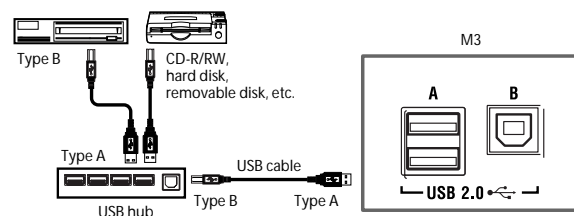

### Hot-plugging

The M3 supports USB hot-plugging. This means that you can connect or disconnect the USB cable while the power is on.

*Note:* In order to use hot-plugging, the USB device you are connecting must also support hot-plugging.

### 8 USB devices maximum

M3 has two separate USB 2.0 A ports, and can support up to 8 USB devices simultaneously. Note that it doesn't matter how the devices are connected; even if you use hubs or different ports, the maximum is always 8 devices.

### USB Power

Some USB devices get their power from the USB connection. These are called "bus-powered" devices, and they are supported by M3.

Other USB devices may require a separate power source, in addition to the USB connection; in this case, you'll need to use an appropriate power adaptor for the device.

There is a limitation to the total current supplied to all connected USB devices, as defined by the USB specification. If the total current consumption of the connected devices exceeds this limit, the M3 may not correctly recognize the connected USB devices. If this happens, an error message of "USB Hub Power Exceeded!" will appear.

To avoid this problem, if you connect more than one USB device, please use a self-powered USB hub in self-powered mode. For details on connections and settings for your hub, please refer to its documentation.

For details on the electrical current used by a specific USB device, refer to its owner's manual.

---

## Installing the software

---

### About the software

The most recent versions of the applications contained in the included CD-ROM can be downloaded from the Korg website (<http://www.korg.com>).

### Please note before use

Copyright to all software included in this product is the property of Korg Inc.

The license agreement for this software is provided separately. You must read this license agreement before you install this software. Your installation of this software will be taken to indicate your acceptance of this agreement.

---

## Operating requirements

### KORG USB-MIDI driver

#### Windows

Operating system: Microsoft Windows XP Home Edition/Professional/x64 Edition Service Pack 2 or later (the MIDI driver for the x64 Edition is a Beta version)

All editions of Microsoft Windows Vista (the MIDI driver for the 64-bit Edition is a Beta version)

Computer: USB port required (a USB host controller made by Intel is recommended)

#### Macintosh

Operating system: Mac OS X 10.3.9 or later

Computer: USB port required

### M3 Editor (stand-alone version)

### M3 Plug-in Editor (plug-in version)

### KORG FireWire Audio/MIDI driver

#### Windows

Operating system: Microsoft Windows XP Home Edition/Professional Service Pack 2 or later

Computer:

CPU Pentium III/1 GHz or better (Pentium IV/2 GHz or better recommended)

Memory 512 MB or more (1 GB or more is recommended)

Monitor 1,024 × 768, 16-bit color or better

If using the optional EXB-FW

A computer with a FireWire (IEEE 1394) port

If using USB B A computer with a USB port

Formats supported by the M3 Plug-In Editor: VST, RTAS

## Macintosh

Operating system: Mac OS X 10.4 or later

Computer:

CPU PowerPC G4 800 MHz or better (PowerPC G5 or Intel Core Duo processor is recommended)

Memory 512 MB or more (1 GB or more is recommended)

Monitor 1,024 × 768, 32,000 colors or better

If using the optional EXB-FW

A computer with a FireWire (IEEE 1394) port

If using USB B A computer with a USB port

Formats supported by the M3 Plug-In Editor: VST, Audio Unit, RTAS

\* M3 Plug-In Editor must also satisfy the operating requirements of the host application.

 You cannot run multiple instances of the M3 Editor and M3 Plug-In Editor on the operating system. This means that you can't use this editor to edit two or more M3 units simultaneously.

## Installing the driver and the editor software in Windows XP

*Note:* In order to install or uninstall software in Windows XP, you must have Administrator privileges. Consult your system administrator for details.

*Note:* Before you connect the M3 to your computer via USB, you must use the M3 application installer to install KORG USB-MIDI Driver Tools.

*Note:* Before you connect the M3 (with the optional EXB-FW) to your computer via FireWire, you must use the M3 application installer to install the KORG FireWire Audio/MIDI Driver.

### Installing the M3 application

The M3 application installer will install the KORG USB-MIDI Driver Tools and the M3 Editor/Plug-In Editor automatically.

#### 1. Insert the included CD-ROM into your CD-ROM drive.

Normally the “M3 Application Installer” will start up automatically.

If your computer is set so the installer does not run automatically, double-click “KorgSetup.exe” on the CD-ROM.

#### 2. Follow the on-screen instructions to install the desired software such as the KORG USB-MIDI Driver Tools and M3 Editor/Plug-In Editor.

*Note:* If you intend to use the M3 Editor/Plug-In Editor via the USB port, you must install the KORG USB-MIDI Driver Tools.

*Note:* If you intend to use the M3 Editor/Plug-In Editor via the FireWire port, you must install the KORG FireWire Audio/MIDI Driver Tools.

#### 3. When you've installed all of the selected software, exit the installer.

#### 4. If necessary, install the KORG USB-MIDI driver.

For details on installation, please see “Installing the KORG USB-MIDI driver,” below.

## Installing the KORG USB-MIDI driver

If you intend to use the M3 Editor/Plug-In Editor via the USB port, you must install the “KORG USB-MIDI driver” in your computer.

Use the KORG USB-MIDI Driver Tools to install the KORG USB-MIDI driver.

1. **Before you continue, you must first finish installing the KORG USB-MIDI Driver Tools in your computer.**
2. **Use a USB cable to connect your computer's USB port to the M3's USB B connector. Then power-on the M3.**

When your computer first detects that the M3 is connected, the Windows default driver will be installed automatically. (This is not the KORG USB-MIDI driver.)

*Note:* The driver must be installed separately for each USB port. If you connect the M3 to a USB port other than the one for which you installed the KORG USB-MIDI driver, you'll need to install the KORG USB-MIDI driver again using the same procedure.

3. **From the taskbar, click [Start]→[All Programs]→[KORG]→[KORG USB-MIDI Driver Tools]→[Install KORG USB-MIDI device].**

The setup utility will start.

4. **Follow the on-screen instructions to install the KORG USB-MIDI driver.**

If during the installation, a dialog box regarding digital signatures appears with a message saying “.... has not passed Windows logo testing,” simply click [Continue] to proceed.

*Note:* If you are unable to proceed with the installation, it may be that your computer has been set to prohibit installation of unsigned drivers. Check the settings of your computer as described in “Allowing installation of drivers that are not digitally signed.”

5. **After you've installed the KORG USB-MIDI driver, exit the installer.**

If you are asked whether you want to restart, choose [Yes] to restart your computer.

For more about installation, setup, or uninstallation of the KORG USB-MIDI driver, refer to the installation manual (HTML).

To view the manual, choose [Start]→[All Programs]→[KORG]→[KORG USB-MIDI Driver Tools]→[Installation Manual].

## About the M3 and USB-MIDI driver ports

### KEYBOARD port

Applications on your computer use this port to receive MIDI messages from the M3 (data from the keyboard and controllers).

### SOUND port

Applications on your computer use this port to send MIDI messages to the M3's internal sound generator, making it produce sound.

## Installing the KORG FireWire Audio/MIDI driver

1. Follow the on-screen instructions to install the KORG FireWire Audio/MIDI driver.

If during the installation, a dialog box regarding digital signatures appears with a message saying “... has not passed Windows logo testing,” simply click [Continue] to proceed.

*Note:* If you are unable to proceed with the installation, it may be that your computer has been set to prohibit installation of unsigned drivers. Check the settings of your computer as described in “Allowing installation of drivers that are not digitally signed.”

2. When a dialog box such as the following appears while you're installing the KORG FireWire Audio/MIDI driver, connect the FireWire (IEEE 1394) cable and power-on the M3.

3. After you've installed the KORG FireWire Audio/MIDI driver, exit the installer.

If you are asked whether you want to restart, choose [Yes] to restart your computer.

## Setting up the M3 Editor/Plug-In Editor

For details on setting up and using the M3 Editor/Plug-In Editor, please see “M3 Editor/Plug-In Editor Manual” (PDF).

## Allowing installation of drivers that are not digitally signed

If the computer you're using has been set to forbid the installation of any drivers that are not digitally signed, you won't be able to install the KORG USB-MIDI driver or the FireWire Audio/MIDI driver. Proceed as follows to change this setting so that you'll be able to install the drivers.

1. From the taskbar, click [Start]→[Control Panel] to access the control panel.
2. In the control panel, double-click [System], and then click the [Hardware] tab.
3. In “Drivers,” click [Driver Signing].

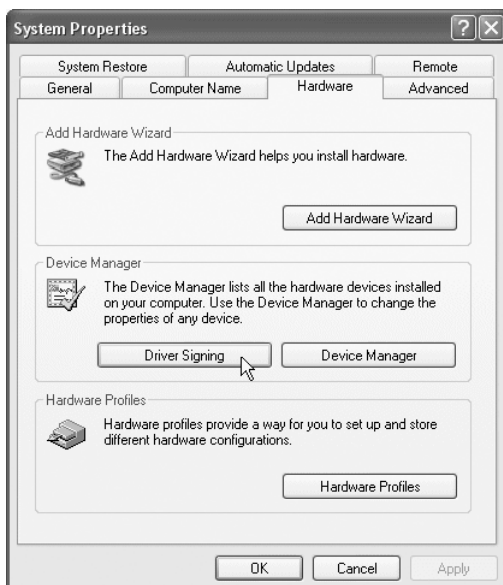

4. In “What action do you want Windows to take?,” choose [Ignore] or [Warn], and then click [OK].

If necessary, you can change this setting back to its original state after you've installed the KORG USB-MIDI driver or the FireWire Audio/MIDI driver.



## Installing the KORG MIDI driver and the editor software in Mac OS X

### Installing the software

You'll need to run the installer separately for each software item such as the KORG USB-MIDI driver and M3 Editor/Plug-In Editor to install them one at a time.

1. Insert the included CD-ROM into the CD-ROM drive of your computer.
2. In the CD-ROM, double-click the software installer (.pkg) to start up the installer.

Each installer is located in the following folder.

- KORG USB-MIDI driver  
“KORG USB-MIDI DRIVER” folder → KORG USB-MIDI DRIVER.pkg
  - M3 Editor  
“M3 Editor” folder → M3 Editor.pkg
3. Follow the on-screen instructions to install each item of software such as the KORG USB-MIDI driver and M3 Editor.

*Note:* If you intend to use M3 Editor via the USB port, you'll need to install the KORG USB-MIDI driver on your computer.

4. When you've finished installing the software, exit the installer.

## About the M3 and USB-MIDI driver ports

### KEYBOARD port

Applications on your computer use this port to receive MIDI messages from the M3 (data from the keyboard and controllers).

### SOUND port

Applications on your computer use this port to send MIDI messages to the M3's internal sound generator, making it produce sound.

## Setting up the M3 Editor/Plug-In Editor

For details on setting up and using the M3 Editor/Plug-In Editor, please see “M3 Editor/Plug-In Editor Manual” (PDF).

# Playing and editing Programs

## About the M3's Programs

Programs are the basic sounds of the M3.

You can play them by themselves, layer them together in Combinations, or play a different Program on each of the 16 MIDI tracks, either from the internal

sequencer or from external computer-based sequencers.

This section of the manual takes a quick look at playing Programs, including tours of the front-panel controllers and basic editing techniques.

## Playing Programs

### Selecting Programs

There are several different ways to select Programs. Each one is convenient in a different way:

- Using "Program Select" and the VALUE controllers  
Choose "Program Select," and then use the VALUE controllers to select a Program.
- Using the Bank/Program Select menu  
In the display, press the "Program Select" popup button, and choose from the menu organized by bank.
- Using the Category/Program Select menu  
In the display, press the "Category Select" popup button, and choose from the menu organized by categories such as piano or drums.
- Using a foot-switch lets you change Programs even while both hands are busy playing on the keyboard - convenient for live applications
- MIDI program change messages let you select Programs remotely, from either -a MIDI sequencer or an external MIDI controller

See below for details.

### Selecting a program using "Program Select" and the VALUE controllers

1. Press the MODE PROG switch. (The LED will light.)  
(Refer to the illustration below for the switches.)

You will enter Program mode.

2. Access the Prog P0: Play- Main page.

This is shown in the top line of the display.

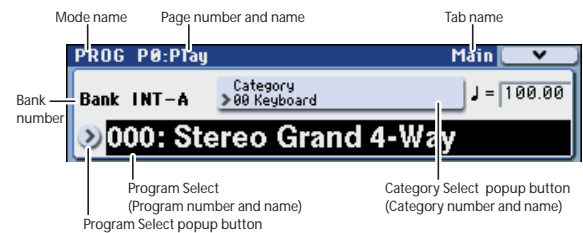

If a different page is shown, press the EXIT switch several times to move to the Prog P0: Play- Main page.

3. Make sure that "Program Select" is selected.

If it is not, press "Program Select" in the display to highlight it.

4. Select the program you want to play.

You can use the following methods to select a program.

- Use the  $\Delta$  or  $\nabla$  switches.
- Turn the VALUE dial.
- Use numeric keys 0-9 to enter the program number, and press the ENTER switch.

5. Press a BANK SELECT I-A-U-G switch to switch banks.

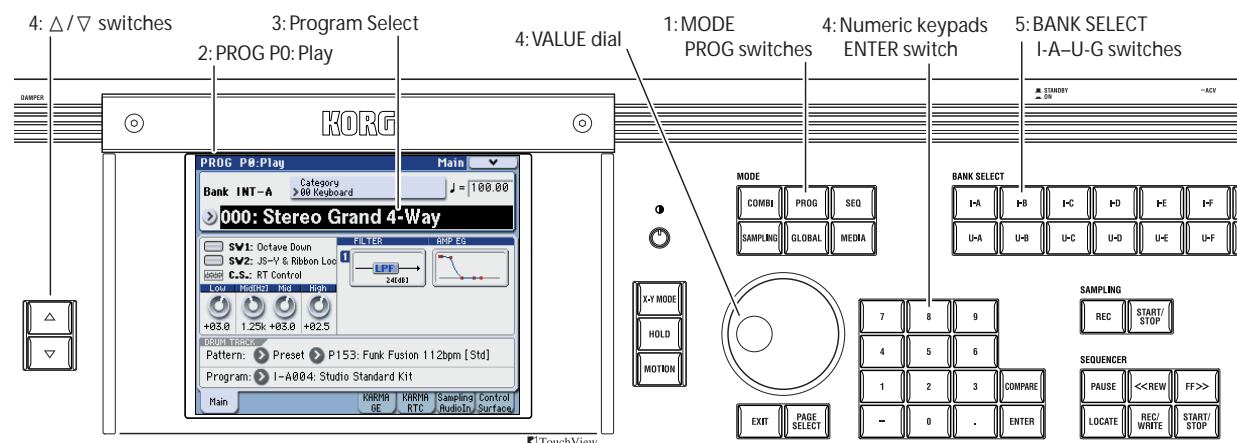



When you select a different Bank, the switch's LED will light, and the selected bank will appear on the left side of the display.

For example, to select bank INT-B, press the BANK SELECT I-B switch. The I-B switch will light, and the name Bank INT-B will appear in the left of the display.

- Each time you press the I-G switch, the bank will alternate as shown below.  
 G→g(1)→g(2)→g(3)→g(4)→g(5)→g(6)→g(7)→g(8)→g(9)→g(d)→G→g(1)→...

### Auditioning the sound

To hear the program you selected, play the KYBD-61/73/88 or a MIDI-connected keyboard. Alternatively, you can strike the M3-M's pads to hear the program.

### Overview: Program Banks

With the factory settings, the M3 contains 512 preloaded programs, and 256 programs and 9 drum programs that are GM2 compatible. In addition to these you can store sounds that you create, as well as optional sound libraries, giving you a total of 1,536 programs.

Programs are organized into fourteen banks as shown in the following table.

Program bank contents

Bank	Prog. No.	Explanation	
INT-A...D	000...127	Factory Programs.	With the factory settings, these banks contain a wide variety of preloaded programs that use the internal PCM ROM multisamples, effects, and KARMA.
INT-E	000...127	Initialized Programs.	Recommended bank for user sampling
INT-F	000...127	EXB-RADIAS Programs.	This can be selected if the optional EXB-RADIAS is installed.
GM (INT-G)	001...128	GM2 main programs.	These banks contain 256 GM programs and nine GM drum programs that are compatible with the GM2 sound map. The programs of these banks are read-only.
g(1)...g(9)	001...128	GM2 variation programs.	
g(d)	001...128	GM2 drum programs.	Bank G contains the GM programs. G lets you select 128 programs numbered from 001–128, and g(1)–g(d) lets you select nine drum programs. You can't write (save) data to these banks.
USER-A...G	000...127	Initialized Programs.	For these banks you can switch the bank type between EDS and EXB-RADIAS. Programs cannot be saved in a bank of a differing type. Specify the bank type using the Global mode menu command "Set Prog User-Bank Type" (See PG page 382).

For details on the factory-set programs, refer to the "Voice Name List" on the included CD-ROM.

### Selecting by Bank/Program Select menu

You can select Programs from a menu organized by Program bank.

**1. Press the Program Select popup button.**

The Bank/Program Select menu appears.

Bank/Program Select menu

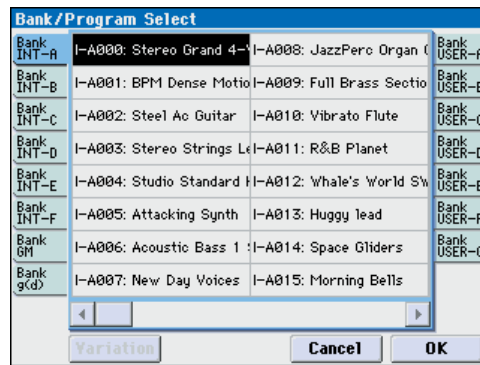

In this illustration, bank Bank GM is selected. The menu the Programs contained in that bank.

**2. Press the tabs in the left and right of the display to select banks.**

**3. Press one of the program names in the center area to select a program.**

The selected program will be highlighted, and the program will change.

Alternatively, you can use the  $\Delta/\nabla$  switches to switch programs.

Play the keyboard or strike the pads to hear the program you selected.

**4. If you selected Bank GM, the Variation button is shown.**

By repeatedly pressing this Variation button you can cycle through the banks in the same way as by pressing the front panel INT G switch.

**5. When you are satisfied with the selected Program, press the OK button to close the menu.**

If you press the Cancel button, the selection you made here will be discarded, and you will return to the program that had been selected before you opened the menu.



## Selecting by Category/Program Select menu

You can select Programs from within a category, such as keyboard, organ, bass, and drums.

When shipped from the factory, the preloaded Programs are organized into 16 categories, each with several sub-categories. There are also 2 more categories, initially named User 16 and User 17, which you can use and rename as desired.

### 1. Press the Category Select popup button.

The Category/Program Select menu appears.

Category/Program Select menu

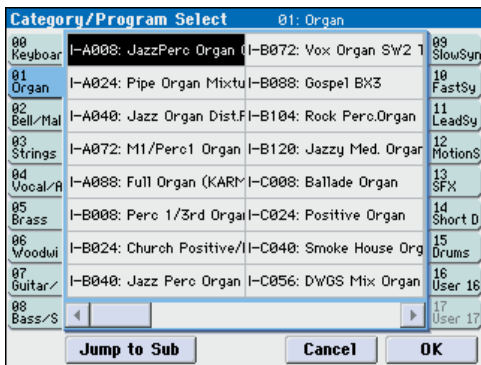

In the illustration above, the Keyboard category is selected. The menu on the left and right shows the Programs which belong to that category.

### 2. Press the tabs in the left and right of the display to select a different category.

The name of the selected category will be displayed in full in the right-hand corner.

### 3. Press one of the program names in the center area to select a program.

The selected program will be highlighted, and the program will change.

Alternatively, you can use the  $\Delta/\nabla$  switches to switch programs.

Play the keyboard or strike the pads to hear the program you selected.

### 4. If you want to select from a sub-category, press the Jump to Sub button to access the Sub Category/Prog Select menu.

Press the left tabs to select a sub-category.

*Note:* You can't select tabs for a sub-category that is not assigned to any program.

Select a program as described in step 3 above.

Press the OK button to confirm your selection, or press the Cancel button to discard it. You will return to the main category.

### 5. When you are satisfied with the selected program, press the OK button to close the menu.

If you press the Cancel button, your selection will be discarded, and you will return to the program that had been selected when you opened the popup menu.

## Using a footswitch to select Programs

You can select programs by using a foot switch connected to the ASSIGNABLE SWITCH jack. By assigning the appropriate function, you can increment or decrement the program number in steps of one.

This lets you change Programs without using your hands—great for quick Program changes in live performance situations.

There are two ways of doing this: by assigning the footswitch to Program Up/Down, or to Value Inc/Dec. Each of these is suited to a particular application, as described below.

### Assigning the footswitch to Program Up/Down

Assigning the footswitch to Program Up or Program Down lets you directly control Program changes from the footswitch. For most situations, this is the more straightforward method.

To set this up:

#### 1. Connect a foot switch to the rear-panel ASSIGNABLE SWITCH input.

Use an optional PS-1 pedal switch.

#### 2. Access the Global P2: Controllers– Foot Controllers page.

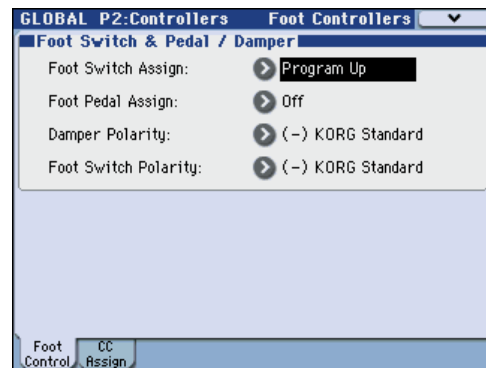

Proceed as follows.

#### 3. Press the MODE GLOBAL switch to enter Global mode.

Press the PAGE SELECT switch to access Global Page Select. Press P2 Controllers, then press the Foot Control tab in the display.

#### 4. Set “Foot Switch Assign” to either Program Up or Program Down.

If you choose Program Up, the next higher program number will be selected each time you press the foot switch.

If you choose Program Down, the next lower program number will be selected each time you press the foot switch.

#### 5. Set the “Foot Switch Polarity” to match the polarity of the pedal you’ve connected.

If you’ve connected the optional PS-1 pedal, choose (-) KORG Standard.

Now, the foot switch will step through the Programs, one by one.

6. If you want to preserve this setting even when the power is turned off, be sure to Write (see page 141).
7. Press the PROG switch to enter Prog P0: Play, and press the foot switch to change the Program.

*Note:* This setting applies to selecting Combinations, as well.

### Assigning the footswitch to Value Inc/Dec

This lets you use the Assignable Foot Switch to duplicate the functions of the front-panel Inc  $\Delta$  or Dec  $\nabla$  switches.

This method is convenient if you want to open the Bank/Program Select menu or Category/Program Select menu and switch programs while viewing the program or combination menu.

With this setting, the Program Up/Down assign method will not function while the menu is open. (Program changes will be ignored while the menu is open.) Make the following settings.

To set this up:

1. Follow steps 1–4 under “Assigning the footswitch to Program Up/Down,” above.
2. At the top of the page, set the Foot Switch Assign parameter to Value Inc (or Value Dec).
3. Now, the foot switch will act just like pressing the front-panel Inc  $\Delta$  or Dec  $\nabla$  switches.

*Note:* The footswitch will work like this for the entire M3—not just when the Program or Combination Select window is open.

---

## Using MIDI Program Change

You can send MIDI Program Change messages to M3 from external MIDI devices, such as DAW software or other MIDI controllers. In conjunction with MIDI Bank Select, you can use these to select any Program from all 14 Banks.

If you use the included “M3 Plug-In Editor” as a plug-in inside your DAW software, you’ll be able to easily select M3 programs or combinations from a list within your DAW. For details, refer to the included “M3 Editor/Plug-In Editor Manual” (PDF).

### Transmit/receive MIDI channel settings

All transmission and reception of MIDI data in Program mode is performed on the **Global MIDI Channel**. You can set this in Global mode, on the Global P1: MIDI– MIDI Basic page. (See “MIDI-related settings for the entire M3” on page 131)

### Bank select settings

You can specify the program and combination sound mapping for Bank Select control change messages (CC#0: upper byte, CC#32: lower byte). Make these settings in **Bank Map** (Global P0: Basic Setup– System Preference page). (See PG page 358)

### MIDI filter settings

You can use MIDI filters to specify whether program changes and bank select messages will be transmitted and/or received. Make these settings in the Global P1: MIDI– MIDI Routing page. (See page 131, and PG page 367)

---

## Performing with KARMA and the Drum Track

Based on your keyboard playing or on the note data received from MIDI IN, the KARMA function automatically generates a diverse variety of phrases or patterns, such as guitar or keyboard backing riffs, bass phrases, or drum patterns. You can use the KARMA sliders and the KARMA switches to freely modify these phrases or patterns.

For more about the KARMA function, please see page 163.

The Drum Track function plays a rich variety of drum patterns using the M3’s high-quality drum programs. You can play programs along with the drum patterns.

Of course, phrases generated by KARMA can be synchronized with Drum Track patterns and used together with them.

For more about the Drum Track function, please see page 185.

## Using Controllers

The M3 provides a control surface with sliders and switches, an X-Y control function, and pads, giving you a wide range of ways in which to vary the sound.

In addition to a keyboard, the M3 KYBD-61/73/88 provides a joystick, ribbon controller, and SW1/SW2 switches to let you control the sound.

These controls let you modify the tone, pitch, volume, effects, etc. in realtime while you play.

### The controllers of the M3 KYBD-61/73/88

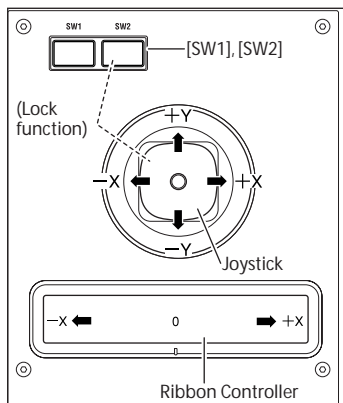

### Joystick

The joystick moves in four directions: left, right, up (away from yourself), and down (towards yourself). Each of the four directions can be used to control a different function, such as modulating Program or effects parameters. These assignments can be different for every Program, but generally, they do the following:

*Standard Joystick functions*

Move the joystick...	Controller Name	Normally controls...
Left	JS-X	Pitch bend down
Right	JS+X	Pitch bend up
Up (away from yourself)	JS+Y	Vibrato
Down (towards yourself)	JS-Y	Filter LFO (wah)

### Joystick Lock

The joystick will automatically return to the center position when you release it.

You can use the KYBD-61/73/88's SW1/SW2 switches or a foot switch connected to the M3-M to lock the current position so that the effect will continue even after you return the joystick to the center position. For details, please see "Using the Lock function" on page 41.

### Ribbon Controller

Move your finger to the left and right on the ribbon controller to apply an effect.

Normally, this is used to control pitch, volume or filter etc.

You can use the Lock function of SW1 or SW2 switches to hold the effect even after you release your finger from the ribbon controller. For more details, please see "Using the Lock function" on page 41.

### SW1, SW2

You can use these switches to control program parameters via AMS (Alternate Modulation), or effect parameters via DMod (Dynamic Modulation).

They can also transpose the keyboard by octaves, turn portamento on/off, or lock the position of the ribbon controller, joystick, or aftertouch.

Each switch can work as either a **Toggle** or **Momentary** switch. In **Toggle** mode, the assigned function is switched between on and off each time the switch is pressed. In **Momentary** mode, the assigned function is active on only as long as you hold down the switch.

In Program mode, you can check the assignments of SW1 and SW2 on the Prog P0: Play- Main page. For more details, please see "Controller settings for the program" on page 46.

When you write a Program or Combination, the on/off status of the SW1 and SW2 switches is saved.

For more details, please see "Setting the functions of SW1 and SW2" on page 198.

### Using the Lock function

#### Locking the Joystick

1. **Using the standard factory sounds, select Program INT-A016: Real Suit E.Piano, and play the keyboard.**

To select a program, make sure that you are in Program mode, and press the BANK INT A switch, numeric key 1, 6, and then the ENTER switch.

2. **Move the joystick away from yourself (the +Y direction).**

The vibrato effect will deepen.

3. **While holding the joystick away from yourself, press the SW2 switch.**

When you press the switch, its LED will light up, and the modulation effect at this point will be maintained.

4. **Release the joystick, and play the keyboard.**

The modulation will stay the same as it was when SW2 was pressed. Moving the joystick away from yourself will not affect the sound.

5. **Press the SW2 switch once again to release the Lock function.**

### Locking the Ribbon Controller

Make sure that the INT-A016: Real Suit E.Piano program is selected.

1. Press the SW2 switch.

The LED will light up.

2. Touch the ribbon controller, and move your finger left and right.

Movement in the +X direction will brighten the tone, and movement in the -X direction will darken the tone.

3. Lift your finger up from the ribbon controller.

The sound will remain as it was when you last touched the ribbon.

4. Press the SW2 switch once again to release the Lock function.

Press the tab labeled Main, to go to the P0: Play- Main page.

In the upper right-hand portion of the display, notice that SW2 is assigned to JS Y & Ribbon Lock. This means that SW2 is assigned to control the Lock function for both the joystick's Y axis and the ribbon controller. The switch operates as a toggle. Many Programs and Combinations use this assignment.

You can also lock both the ribbon and the joystick at the same time:

1. Move the joystick in the +Y direction
2. Press the SW2 switch to turn on the Lock function.
3. Move your finger on the ribbon controller.
4. Release the joystick, and lift your finger up from the ribbon.

The effects of both the ribbon and the joystick will be maintained until you press SW2 again to release the lock.

Lock can also be applied to aftertouch, by assigning SW1 or SW2 to After Touch Lock.

For details on the functions that you can assign to SW1 and SW2, please see "SW1/2 Assignments," on page 597 of the Parameter Guide.

## Keyboard

### Velocity

Velocity is a measure of how hard you play a note on the keyboard. This can be used to modulate many different aspects of the sound, such as volume, brightness, or the character of the attack.

### Aftertouch

The keyboard can also measure how hard you press down after you play a note—hence the term "aftertouch." You can use this to shape notes over time, controlling (for instance) volume or vibrato amount.

### Note Number

Sounds can be programmed to change in character based on the note being played. As you play higher or lower on the keyboard, the note number can modulate the timbre—such as becoming brighter as you play higher. Envelopes may also become faster or slower; the volume may change; and so on.

## The controllers of the M3-M

### Control Surface sliders, & switches

The control surface consists of eight sliders, eight switches, and control assign switches that select the functions to be controlled.

- You can control mixer functions such as volume, mute, and solo on/off for oscillators and audio inputs.
- You can apply modulation to sounds or edit them.
- You can control the KARMA function.
- You can control external MIDI devices.

1. Use the CONTROL ASSIGN MIXER-KARMA switches to select the function you want to control.

Alternatively, you can use the Prog P0: Play- Control Surface page **Control Assign** parameter to select a function. Press the Control Surface tab in the lower line of the display to access this page.

Since this parameter is linked with the front panel switches, a change you make to one will be reflected by the other.

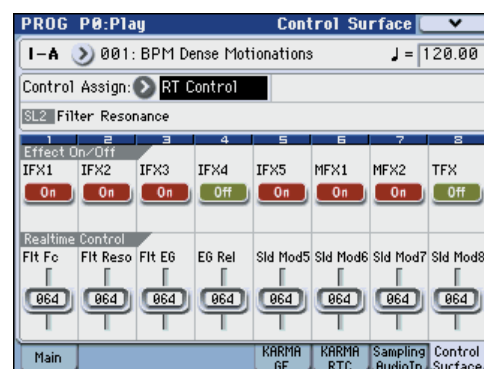
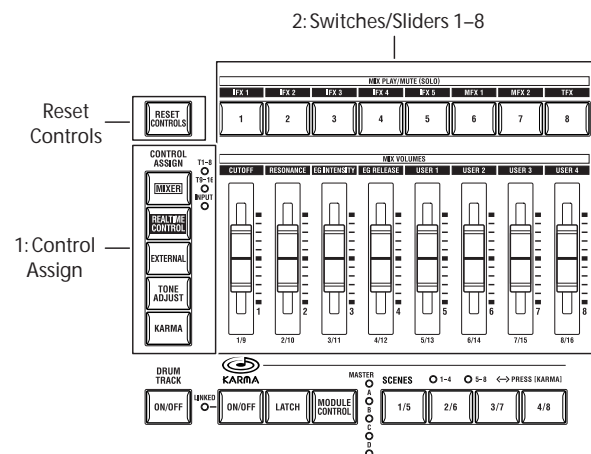

In Program mode, you can select one of five different functions:

### MIXER

**(OSC Mix):** Adjust the volume, Play/Mute, and Solo On/Off status for oscillators 1 and 2 and the drum track. (In Combination mode and Sequencer mode, use the switch to move between timbres or tracks 1–8 or 9–16.)

**(Mixer Input):** Adjust the volume, Play/Mute, and Solo On/Off status for the analog inputs and the S/P DIF and FireWire (if the EXB-FW is installed) audio inputs.

The Solo On/Off status is linked for the OSC MIX and Mixer Input.

**REALTIME CONTROL (RT Control):** Use the sliders to modify the sound or effects. Use the switches to turn effects on/off.

**EXTERNAL:** Use the sliders and switches to transmit MIDI messages to external MIDI devices. You can assign these functions in the Global P1: MIDI- External Mode 1/2 pages.

**TONE ADJUST:** Use the sliders and switches to directly edit program parameters.

**KARMA:** Use the sliders and switches to control the KARMA function.

You can freely switch between these functions without losing the contents of your editing.

**2. Operate switches 1-8 and sliders 1-8 to control the selected functions.**

For examples of using REALTIME CONTROL, TONE ADJUST, and KARMA, please see page 48, page 49, and page 168.

**Resetting controls to their saved values**

The front-panel **RESET CONTROLS** switch lets you recall the stored settings for any slider, or switch on the control surface.

To reset a single slider, or switch:

1. **Hold down the RESET CONTROLS switch and operate the slider 1-8 or switch 1-8 that you want to reset.**

The slider, or switch will be reset to the value stored in the Program.

2. **When you're done, release the RESET CONTROLS switch.**

To reset a group of controls at once:

- Hold down the **RESET CONTROLS** switch. While holding down RESET CONTROLS, touch any of the CONTROL ASSIGN switches such as MIXER-KARMA. All of the sliders, and switches in the control surface will be reset to the values stored in the Program.
- To reset the sliders and switches for each KARMA module, hold down the RESET CONTROLS switch and press the KARMA MODULE CONTROL switch.
- To reset the each KARMA scene, hold down the RESET CONTROLS switch and press the SCENE 1/5-4/8 switch whose LED is blinking.

**X-Y controller**

The X-Y controller generates control changes when you touch the display and move your finger (X-Y mode), or records these movements as an X-Y motion, letting you control the OSC1 and OSC2 volume balance or modify the program or effect.

(In Combination mode and Sequencer mode, you can adjust the volume balance between the Programs used within the Combination or Song.)

**Using the display to control the X-Y mode**

1. **Press the X-Y MODE switch.**

When you turn on the X-Y MODE switch, the switch LED will light, and the display will change color.

⚠ When the X-Y MODE switch is on, you won't be able to select parameters in the display. Turn this switch off if you want to use the display to edit settings.

2. **Slide your finger over the display to modify the sound.**
3. **If you turn on the HOLD switch (the LED will light) and remove your finger, the effect at that position will be maintained. If the HOLD switch is off, the point will return to the center value (no effect) when you remove your finger.**

*Note:* You can use a foot switch to turn the X-Y MODE switch on/off. Set **Foot Switch Assign** to X-Y MODE. For details, please see "Assigning the footswitch to Program Up/Down" on page 39.

**Recording an X-Y motion**

If there are no events

1. **Press the X-Y MODE switch.**

When you turn on the X-Y MODE switch, the switch LED will light and the display will change color.

2. **Press the MOTION switch to enter the record-ready state.**
3. **Continue holding down the MOTION switch, touch the display and recording will begin. Move your finger to record the motion.**
4. **Recording will end when you release the MOTION switch or when the maximum event capacity is reached.**

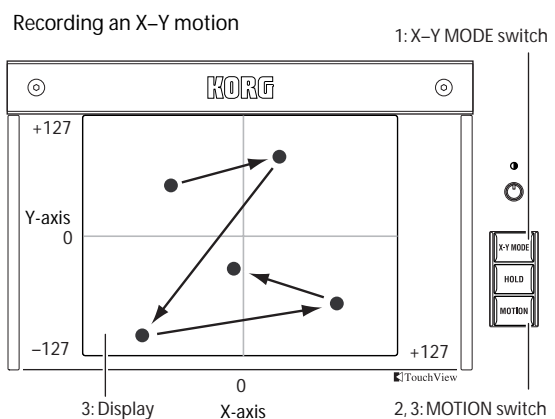

If events already exist

1. **Press the X-Y MODE switch.**

When you turn on the X-Y MODE switch, the switch LED will light and the display will change color.

2. **When you press the MOTION switch, playback will begin.**
3. **If you continue holding down the MOTION switch and touch the display, recording will begin from that point. Move your finger to record the motion.**
4. **Recording will end when you release the MOTION switch or when the maximum event capacity is reached.**



## Playing back an X–Y motion

1. When you press the MOTION switch once again, the old events (up to the point where you began re-recording) and the subsequently recorded events will play back.

Play the keyboard of the KYBD-61/73/88 or strike the pads.

*Note:* If you turn on the X–Y MODE switch and then turn on the MOTION switch, you will see the change indicated by the color of the display.

*Note:* You can use a foot switch to turn the MOTION switch on/off. Set **Foot Switch Assign** to X–Y Motion. For details, please see “Assigning the footswitch to Program Up/Down” on page 39.

## Deleting X–Y motion data

- While holding down the ENTER switch, press the MOTION switch to delete the X–Y motion data.

## Drum & Chord Pads

There are eight velocity-sensitive trigger pads below the display.

These look like drum machine pads, and playing drum sounds is certainly one use for them.

However, they can also play up to eight-note chords on any sound—not just drums. The pads even remember the velocities of the individual notes within the chord, as well as the notes themselves.

## Playing the pads

1. Use the PAD MODE switch located at the left of the pads to select how the pads will operate.

**VELOCITY SENSITIVE:** The loudness will be affected by how strongly you strike the pads.

**FIXED VELOCITY:** The note will be transmitted with the note number and velocity assigned to each pad, regardless of how strongly you strike the pads.

When you specify notes using CHORD ASSIGN, the stored note numbers and velocity balance will always be reproduced.

2. Strike the pads to play sounds.

## Assigning notes and chords to pads

You can assign single notes and chords to the pads in three different ways.

### Selecting the notes first

1. Play a single note, or a chord of up to 8 notes.
2. Press the CHORD ASSIGN switch.
3. Press the pad to which you’d like to assign the notes.

That’s it! The notes are now assigned to the pad.

## Press CHORD ASSIGN, and then play notes

This method lets you create a chord out of widely-spaced notes, even if you can’t play all of the notes simultaneously.

1. Press the CHORD ASSIGN switch.
2. Play a single note, or a chord of up to 8 notes.

You can play a single note, or a simple chord.

If you like, you can also enter a chord by playing up to 8 notes as a legato phrase. As long as you take care that the notes overlap each other, the entire series of notes will be recorded as a single chord. You can take as long as you like to play the phrase.

3. Press the pad to which you’d like to assign the notes.

After pressing the pad, you’re done!

## Editing notes and velocities using the display

You can edit the recorded notes and velocities using the display. If you like, you can also enter new notes this way. For details, please see “1–7: Pads 1–4 Setup, 1–8: Pads 5–8 Setup” on page 36 of the Parameter Guide.

## Copying and merging pads

Copying one pad to another, or merging two or more pads together, is just like assigning notes from the keyboard.

As with assigning notes to the keyboard, you can either play the pads first, or press CHORD ASSIGN first. In the interest of saving space and time, only the first method is described below.

### Copying notes from one pad to another

To copy the note assignments from one pad to another:

1. Press and release the pad whose notes you want to copy.
2. Press the CHORD ASSIGN switch.
3. Press the pad to which you’d like to copy the notes.

The new pad will now play the same notes as the original pad.

### Merging two or more pads together

You can merge the assignments from two or more pads together, as long as the total number of notes is 8 or fewer. To do so:

1. Press all of the pads that you’d like to merge, and then release them.

All of the pads must be held down at the same time.

2. Press the CHORD ASSIGN switch.
3. Press the pad to which you’d like to copy the notes.

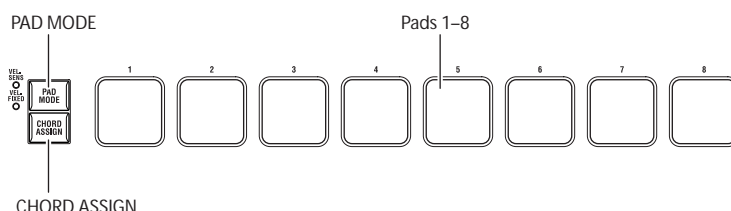



You can even use one of the pads that was being merged, if you like. After pressing the destination pad, you're done.

## VALUE slider

When a program number is selected in Prog P0: Play page, or when a combination number is selected in Combi P0: Play page, you can use the VALUE slider to modulate Program and effects parameters.



## Damper Pedal

### Damper Pedal (Sustain)

The damper pedal is also sometimes called the sustain pedal. It acts like the similarly-named pedal on an acoustic piano; when you hold down the pedal, notes will continue to sustain even when you lift your hands off of the keyboard.

### Damper Switch vs. Half-Damper

You can use either a standard footswitch (such as the Korg PS-1) or a special half-damper pedal (such as the Korg DS-1H) as the Damper.

If you use a footswitch, it will work like a normal synthesizer sustain pedal: notes will sustain forever, as long as the pedal is held down.

A half-damper pedal is a special type of continuous foot pedal (normal foot pedals won't work properly for this application). It offers more subtle control of sustain, which can be especially useful for piano sounds.

The off and full-on positions of the half-damper work just like the footswitch, but intermediate positions modulate the release time to increase sustain without making it infinite.

The M3 will automatically sense when a half-damper is connected to the rear-panel DAMPER input. For proper operation, you will also need to calibrate the pedal, using the **Half Damper Calibration** command in the Global menu. For details, please see "Half Damper Calibration" on page 383 of the Parameter Guide.

### Damper and MIDI

The Damper Pedal is sent and received as MIDI CC #64.

In Combination and Sequencer modes, you can "filter" CC# 64 so that it only affects some of the sounds in the Combination or Song.

## Foot Switch

### Assignable Foot Switch

This lets you use a simple footswitch, such as the Korg PS-1, as an assignable controller. The footswitch can perform a wide variety of functions, such as:

- An assignable source for modulating sounds and effects
- Portamento on/off
- Program select up or down
- Sequencer start/stop or punch in/out
- Tap Tempo
- KARMA on/off, Latch on/off, or Scene select
- Switch the Drum Track on/off
- Switch X-Y mode or X-Y motion on/off
- Operate various M3 controls (VALUE slider, pads, realtime control sliders, KARMA sliders/switches, joystick, ribbon controller, SW1/SW2, etc.)

The switch's function is set in Global mode (Global P2: Controllers- Foot Controllers page), so that it always works the same regardless of the current Program, Combination, or Song.

For details, please see "Specifying the function of the Assignable Switch and Assignable Pedal" on page 132.

### Assignable Foot Pedal

This lets you use a continuous controller pedal, such as the Korg EXP-2 foot controller or Korg XVP-10 EXP/VOL pedal, as an assignable controller.

Like the Assignable Foot Switch, described above, the Foot Pedal can be used for many different functions, including:

- Master Volume
- Channel Volume, Pan, or Expression
- Assignable sound modulation, as several different AMS or Dmod sources
- Effects Send level control
- Operate various M3-M, KYBD-61/73/88 controls (VALUE slider, realtime control sliders, KARMA sliders/switches, Joystick, Ribbon controller, SW1/SW2, etc.)

The pedal's function is set globally (on the Global P2: Controllers- Foot Controllers page), so that it always works the same regardless of the current Program, Combination, or Song.

For details, please see "Specifying the function of the Assignable Switch and Assignable Pedal" on page 132.

## Controller settings for the program

The Prog P0: Play- Main page lets you view the following information.

**SW1, SW2:** Indicates the functions controlled by the SW1/SW2 switches of the KYBD-61/73/88.

**C.S.:** Indicates the currently selected control assign setting. Control via the control surface is active in all pages.

**FILTER 1, 2:** Indicates the filter type setting for filter 1 and 2.

**AMP EG 1, 2:** Indicates the EG setting for amp 1 and 2.

**EQ (Low, Mid[Hz], Mid, High):** Indicates the 3-band EQ settings. You can use the VALUE controller to edit the values.

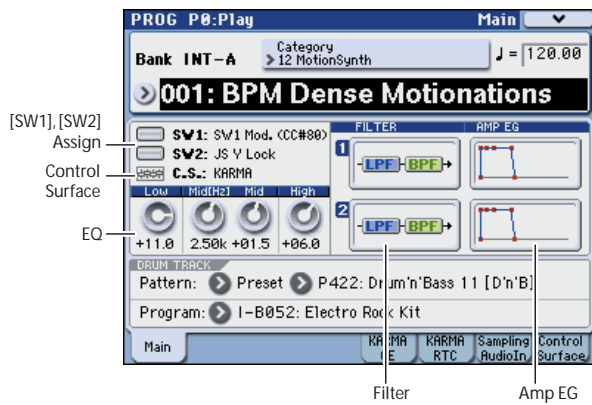

# Easy Program editing

## Simple editing using the sliders and switches

All of the M3's programs can be edited. You can start by editing a preloaded program, or you can initialize a program and create your own from scratch.

It is a lot of work to create the sound you want by starting with an initialized program. In most cases, you should start with a preloaded program that's close to what you have in mind, and then edit it to your taste. On the M3, you can use the switches and sliders of the front panel control surface to make very effective edits simply from within the Prog P0: Play page.

For example, you can operate the sliders to adjust the attack time or release time, or to vary the cutoff or resonance. You can also turn effects on/off or adjust their depth, or vary the phrases generated by KARMA.

## Adjusting the EQ

You can adjust a mid-sweepable three-band EQ in the Prog P0: Play- Main page. This EQ will affect both oscillator 1 and oscillator 2.

1. Access the Prog P0: Play- Main page.
2. In the display, select the EQ that you want to edit.
3. Use the VALUE controllers (e.g., VALUE slider) to edit the value.

**Low:** Adjusts the gain of the 80 Hz low shelving EQ in 0.5 dB steps.

**Mid [Hz]:** Adjusts the center frequency of the mid-sweepable EQ.

**Mid:** Adjusts the gain of the mid-sweepable EQ in 0.5 dB steps.

**High:** Adjusts the gain of the 10 kHz high shelving EQ in 0.5 dB steps.

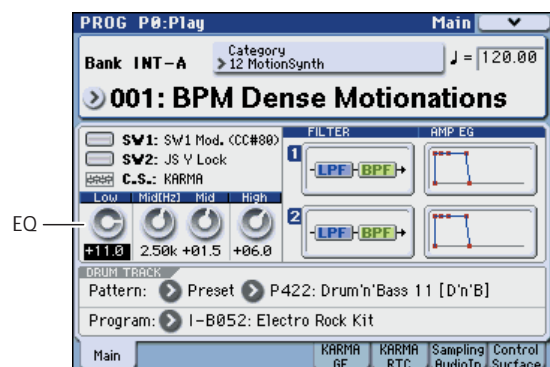

## Controlling Volume, Mute, and Solo for Oscillators 1/2 and the Drum Track

You can use the sliders and switches of the control surface to control volume, mute, and solo for the oscillators and drum track.

1. Press the CONTROL ASSIGN MIXER switch to make the T1-8 LED light.

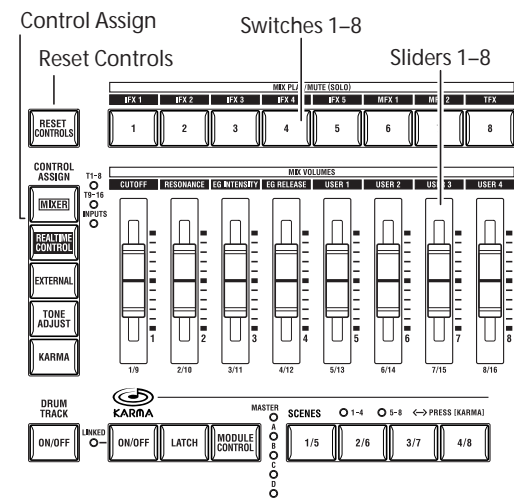

2. Access the Prog P0: Play- Control Surface page.

In this page you can view and edit the control surface settings. This is a convenient way to adjust your sound, since you can see the parameter assignments and the precise values.

*Note:* The control surface is active regardless of the page that is shown in the display.

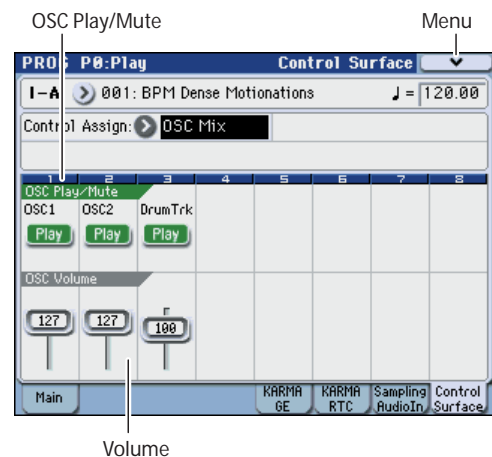

3. Use sliders 1, 2, and 3 to adjust the volume of oscillators 1 and 2 and the drum track.

*Note:* For single-oscillator programs, you won't be able to control oscillator 2.

4. If the display indicates OSC Play/Mute, you can press switches 1, 2, or 3 to switch the Play/Mute status of oscillators 1 and 2 and the drum track.
5. Press the menu button and choose "Panel-SW Solo Mode." The menu will close, and the OSC Play/Mute indication in the display will change to OSC Solo.

Alternatively, you can switch between OSC Play/Mute and OSC Solo by holding down the ENTER switch and pressing numeric key 1.

6. If the display indicates OSC Solo, you can press switches 1, 2, or 3 to switch the Solo on/off status of oscillators 1 and 2 and the drum track.

## Using realtime control to edit sounds or effects

You can use the control surface to control the sound or effects in realtime.

1. Press the CONTROL ASSIGN REALTIME CONTROL switch (the LED will light).
2. If desired, display the Prog P0: Play- Control Surface page.

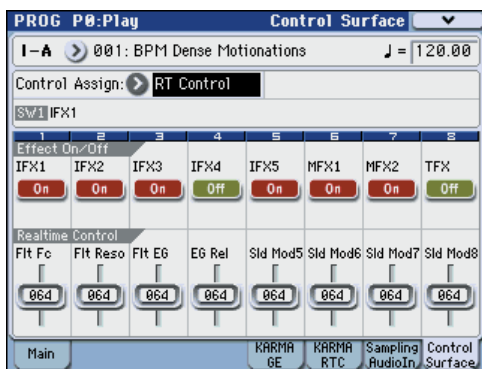

3. Sliders 1-4 will be assigned specific functions corresponding to MIDI control changes.

Sliders 5-8 can be assigned to a wide variety of functions, many of which also have corresponding MIDI CCs.

Often (but not always), slider 5 and 6 modulate synthesis parameters, slider 7 controls the depth of a chorus or other modulation effect, and slider 8 controls reverb depth.

When you move a slider, it sends out the corresponding MIDI CC. Also, when the CC is received via MIDI or generated by KARMA, the slider value changes to match the CC value.

Generally, the sliders “scale” the Program’s internal settings. When the slider is in the center, the settings are as programmed. To change the setting to the maximum value, move the slider all the way up. For the minimum value, move the slider all the way down.

### Slider scaling

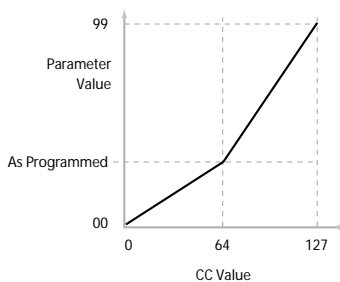

4. You can use switches 1-8 to turn insert effects 1-5, master effects 1/2, and the total effect on/off.

For example:

1. Select Program INT-B045, “Smooth Operators.” This is an electric piano sound; let’s see what we can do to make it sound a bit different.
2. Press the CONTROL ASSIGN REALTIME CONTROL switch (the LED will light).
3. While you perform, slowly raise slider 1 (filter frequency) to about three-quarters of its full range. Notice how the piano becomes a sort of synth sweep.
4. Next, raise slider 2 (filter resonance) to about three-quarters as well.
5. Leaving slider 2 at that position, try raising and lowering slider 1.

With the resonance increased, it now sounds like you’re playing through a wah pedal.

## Reset

Next, let’s say that you decide that’s not really what you wanted—so, we’ll set the sliders back to their default values. Although you could return the slider to its middle position and then make fine adjustments to set it precisely to the center, there is an easier way.

1. Hold the RESET CONTROLS switch.
2. While holding RESET CONTROLS switch, move first slider 1, and then slider 2.

As you move the sliders, their values will be reset to the default, center positions.

3. Release the RESET CONTROLS switch.

Now, you’re back to the original electric piano sound.

The table below shows the standard assignments of the RT Control sliders:

### Real-Time slider functions

Slider	MIDI CC	Normally controls...
1	74	Filter Cutoff Frequency
2	71	Filter Resonance
3	79	Filter EG Intensity (CC#79)
4	72	EG Release Time
5-6	Varies for each Program	
7	Often Chorus Depth - but can vary per Program	
8	Often Reverb Depth - but can vary per Program	

## Saving the edits you made by moving the sliders

The Real-Time sliders are great for modulating sounds in performance, or for recording. If you like, you can also save the edited version of the sound, using the normal Write Program command (see “Saving your edits” on page 50).

Internally, a single slider usually affects several different parameters. When you write a Program, the edits are saved into the individual parameters, and not to the slider itself. After writing the Program, you’ll notice that the sliders have returned to their center positions—since the old “edited” values are now the new “saved” values.

## Using Tone Adjust

The Tone Adjust function lets you use the Control Surface sliders and switches to edit program parameters. The controllers will be assigned the program parameters that are most effective for editing.

1. **Press the CONTROL ASSIGN TONE ADJUST switch (the LED will light).**
2. **Access the Prog P0: Play– Control Surface page.**

This page shows and reflects the control surface data. Since you can view the parameter assignments and the precise value, this is convenient when adjusting the sound.

3. **Use sliders 1–8 and switches 1–8 to adjust the sound.**

*Note:* You can assign the main parameters of the program to the controllers. (See “Tone Adjust” on page 19 of the Parameter Guide)

**For example:**

1. **Select Program INT-B045, “Smooth Operators.”**
2. **Press the CONTROL ASSIGN TONE ADJUST switch (the LED will light).**
3. **Access the Prog P0: Play– Control Surface page.**

This page mirrors the Control Surface. It’s very useful with Tone Adjust, since it shows you the parameter assignments, exact values, and so on.

4. **Look at the assignments for sliders 5, 6, and 8.**

Slider 5 is assigned to **F/A EG Attack Time**; slider 6 is assigned to **F/A EG Decay Time**; and slider 8 is assigned to **F/A EG Release Time**.

5. **Raise each of the three sliders so that they are about 4/5 of the way to the top.**

The display should show their values as between +60 and +70. This means that you have edited the filter EG and amp EG attack, delay, and release to longer values.

6. **Play a few notes.**

Notice that the sound has changed from an electric piano into a soft pad. Next, let’s add just a bit of pitch modulation, to make the sound more rich.

7. **Notice the assignment of slider 2.**

Slider 2 is assigned to “[OSC1] Filter LFO1 Int A” (OSC1 filter LFO1 intensity). It will adjust the amount of filter modulation produced by LFO1.

8. **Lower slider 2 slightly so that the display indicates about –6.**

9. **Play a few more notes.**

The pitch modulation has added some shimmer to the sound. Now, maybe it could use a bit more edge...

10. **Look at the assignments for switches 6 and 7.**

These are programmed to raise the **Filter Cutoff** and **Filter Resonance**, respectively. Switches are just on/off, but you can set a specific value for the **On** position; notice the +10 and +40 in the switch’s value boxes.

11. **Press each of the two switch buttons.**

The sound now has a more interesting character, due to the filters. Since it’s brighter, we’ve also restored some of the electric piano character.

Pretty easy, huh? Note - depending on the parameter, you may sometimes hear glitches in the sound as you move the control.

## Changing parameter assignments

The factory Programs include default assignments of Tone Adjust parameters to the sliders, and switches. If you like, you can change any of the assignments. To do so:

1. **Press the CONTROL ASSIGN TONE ADJUST switch of the Prog P0: Play– Control Surface page.**

On this page, you can see the parameter assignments for each controller, such as **Filter EG Attack**, **Pitch Stretch**, **Reverse**, and so on.

2. **Press the popup button located at the left of the assigned parameter.**

A popup window will appear, with a long menu of parameters. You can tell various things about the selections, just from the way they appear in the menu:

Parameters which affect only OSC1 or OSC2 are prefixed with [OSC1] and [OSC2], respectively.

Parameters which affect both Oscillators, but which are specific to EDS Programs, are prefixed with [OSC1&2].

The other group of parameters, at the beginning of the list, are “Common.” That is, you can use them with most RADIAS Programs, as well as EDS Programs.

*Note:* You can use RADIAS Programs only if the optional EXB-RADIAS is installed.

Parameters can only be assigned to one Tone Adjust control at a time. If a parameter is already assigned, it’s grayed out.

3. **Select a parameter from the menu.**

The parameter is now assigned to the control. To close the list without making any changes, press a location in the display outside the popup window, or press the EXIT switch.

## Using COMPARE

When you’re in the process of editing a sound, pressing the COMPARE switch will recall the saved version of the sound, as it was before you started editing.

1. **While editing, press the COMPARE switch (the LED will light).**

The saved sound from before you began editing will be recalled.

2. **Pressing COMPARE again returns you to the version you are editing, and the LED will go out again.**

*Note:* If you edit while the COMPARE LED is lit, the switch will again go dark and your previous edits will be lost.

## Resetting individual controls

The RESET CONTROLS switch lets you revert an individual slider, or switch to its saved setting.

For details, please see “Resetting controller values” on page 199.



## Saving your edits

Once you've tweaked the sound to perfection, you'll want to save your work. To save your edits:

1. **Select the Write Program command from the menu, at the menu right-hand corner of the display.**

You can also call up this menu command by holding **ENTER** and pressing **0** on the numeric keypad.

This brings up a dialog box which allows you to save the Program. Optionally, you can also select a new location, change the Program's name, and assign it to a sound category (such as keyboard, guitar, etc.).

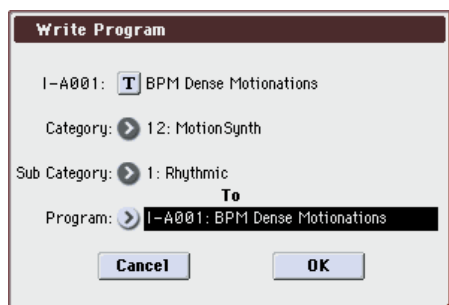

2. **If desired, you may save just the edited content without changing the program name or the location in which the program is saved (the bank and program number). Proceed to step 6.**
3. **If you want to change the program name, press the “T” button to access the text edit dialog box.**

You can give the Program a descriptive name using the text edit dialog box.

After entering the name, press OK.

The text edit window will disappear, returning you to the main Write dialog.

4. **If you want to change the category or sub-category, press the “Category” or “Sub Category” popup button and make your selection from the menu.**
5. **If you want to change the save location (bank and program number), press the To Program popup button, select the save location from the menu, and press the OK button.**
6. **Under “To” at the bottom of the dialog, press the popup button next to Program to bring up the save location dialog.**

7. **Select a location to save the edited Program.**

You can write to any location in banks INT–A–E and USER A–G. To avoid overwriting the factory sounds, it's safer to use a slot in one of the empty User banks.

**⚠ Important:** EDS Programs can only be written to EDS Banks, and RADIAS Programs can only be written to RADIAS Banks. For more information on the default Bank types, and on how to change them, please see “Bank (Bank Select)” on page 4 of the Parameter Guide.

8. **After selecting the location, press OK.**
9. **Press OK again to start the write process.**
10. **If you're sure you want to write to this location, press OK again.**

After that, you're done!

For details, please see “Writing a Program or Combination” on page 140.

### Saving edits to GM Programs

You can edit GM Programs, but you must then save them to a Bank other than INT-G; the GM Programs themselves cannot be over-written.

#### Shortcut: SEQUENCER REC/WRITE

You can also use the SEQUENCER REC/WRITE switch to quickly update the current Program, using the existing name, bank, number, and category. To do so:

1. **Press the SEQUENCER REC/WRITE switch.**

The Update Program dialog will appear.

2. **Press OK to write the program.**

### Saving to a USB storage device

You can manage your data by saving programs on a USB storage device (commercially available). For details, please see “Saving to media (Media-Save)” on page 142.



# Detailed Editing with Programs

## Creating your own Programs

You can create original sounds by editing a preloaded program or by editing an initialized program. The programs (EDS) you create can be saved in banks INT-A-INT-E or USER-A-USER-G. For details, please see “Saving your edits” on page 50.

You can also create Programs using RAM multisamples that you have sampled or loaded from media. In addition, you can play a Program and resample your performance, or sample an external audio source while listening to the sound of a Program.

*Note:* When the M3 is in its factory-set state, EDS Programs are the only programs that can be used. If you install the optional EXB-RADIUS, you’ll be able to use RADIUS Programs. Here we will explain EDS Programs. For more about RADIUS Programs, please see “EXB-RADIUS for M3 Manual” on the CD-ROM.

## Overview of editing pages

P0: Play is where you select and play programs, make quick edits using the Control Surface, and adjust the KARMA settings. The other pages let you modify the sound in more detailed ways.

*Program mode page structure*

	Page	Main content
PLAY	P0: Play	Select and play programs. Simple KARMA editing. Audio input settings and resampling settings. Editing from the control surface.
	P1: Basic/DT/Ctrls	Basic program settings, such as voice assign mode. Drum Track settings. X-Y control settings. SW1, 2, and slider function settings. Pad note and velocity settings.
EDIT	P2: OSC/Pitch	Oscillator selection and pitch settings.
	P3-1: Filter1	Filter 1 (tone) settings.
	P3-2: Filter2	Filter 2 (tone) settings.
	P4: Amp/EQ	Amp 1, 2 (volume) settings. Amp 1, 2 driver and pan settings. 3-band parametric EQ settings.
	P5: LFO	LFO settings.
	P6: AMS/ Common KeyTrack	AMS Mixer settings. Common keyboard tracking settings.
KARMA	P7-1: KARMA1 GE Setup/Module	Overall settings for KARMA, and settings for each module.
	P7-2: KARMA2 GE RTP/Perf	KARMA realtime parameter settings and performance parameter settings.
EFFECT	P8: IFX	Oscillator output bus and master effect send level settings. Insert effect routing, selection, and settings.
	P9: MFX/TFX	Master effect routing, selection, and settings. Total effect selection and settings.

For details on how to access each mode and page, please see “Basic operations” on page 22.

Sampling or resampling can be performed in Program mode. For details, please see “Sampling in Program, Combination, and Sequencer modes” on page 122.

Since you can apply the M3’s internal effects to the external audio inputs, a wide range of possibilities are available. For details, please see “Program Effects settings” on page 155.

## Basic oscillator settings

### Program type setting (single, double, drum kit)

Here you can specify the type of program (whether to use one oscillator, two oscillators, or a drum kit). Use the Prog P1: Basic/DT/Ctrls- Program Basic Oscillator Mode to specify the program type.

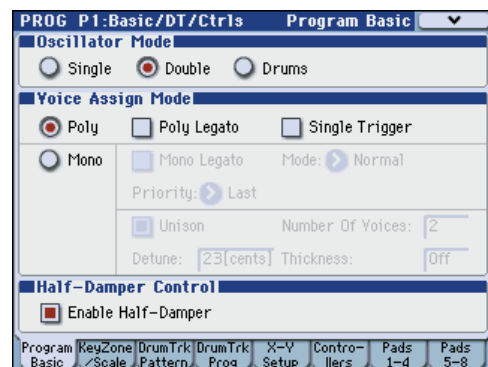

**Single** Programs have one oscillator, and **Double** Programs have two oscillators. Each oscillator is a multisample that is switched by a crossfade velocity switch. You can use dual filters, EG, and LFO to create the sound.

**Drums** mode is a special variation of Single mode, and uses a Drum Kit (as created in Global mode) instead of Multisamples.

### Polyphony

Polyphony is the number of notes that can be played simultaneously, such as in a chord. The polyphony depends on the program type.

Program type	Polyphony
Single	120
Double	60
Drums	120

*Note:*

- Double Programs use twice as many voices as Single Programs.
- Stereo Multisamples use twice as many voices as Mono Multisamples.
- If using velocity crossfade switching, the multisample will use twice as many voices as usual.

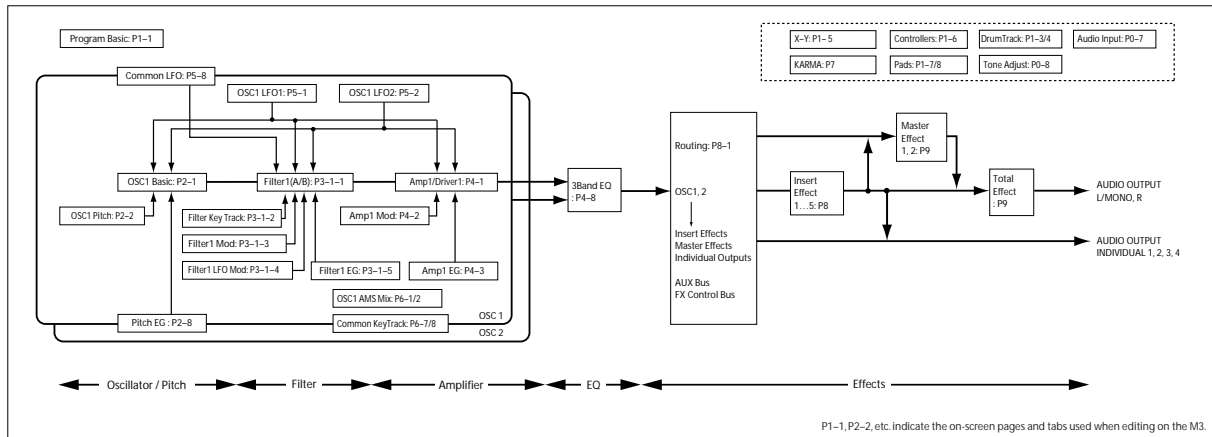

## Polyphonic/monophonic playing

The Voice Assign Mode selects whether the Program will play polyphonically (**Poly**) or monophonically (**Mono**).

When this is set to **Poly**, you can play both chords and melody lines. When this is set to **Mono**, only one note will sound even if you play a chord.

Normally you'll set this to **Poly**, but **Mono** is useful when playing sounds such as synth basses, synth leads, and other solo instruments.

Try switching between Poly and Mono, and listen to the results.

## Working with Multisamples

### What is a multisample?

A sample is a digital recording of a particular instrument or waveform (or other natural or artificially processed sound) recorded at a specific pitch. A multisample is a collection of similarly voiced samples, used to create the same type of sound - piano, bass, guitar, strings, organ - across the entire keyboard, as the basis of a program. The oscillators of single and double programs use multisamples. There are 1,032 multisamples available in this instrument.

You can assign up to four multisamples to each oscillator and switch between them by velocity.

### Multisamples and Drum Kits

Multisamples and Drum Kits allow you to play samples in different ways.

- Multisamples lay out one or more samples across the keyboard. If we use the example of a simple guitar multisample, one sample could be assigned for each string, so that the multisample would consist of six samples.
- As the name suggests, Drum Kits are optimized for playing drumsamples.

### Velocity splits, crossfades, and layers

As mentioned above, unless you're in Drum mode, each Oscillator has four velocity zones, named MS1 (High) through MS4 (Low). This means that the

Program can play different Multisamples, depending on how hard you play.

Each of these zones has separate settings for Level, Start Offset, and so on. Also, each of the zones can fade into the next, to create smooth velocity transitions. Zones can even be layered together, two at a time.

### Selecting Multisamples

Let's create a simple velocity crossfade between two Multisamples, using just OSC1.

1. Access the Prog P2: OSC/Pitch- OSC1 Basic page.
2. Set the Multisample On/Off for MS1 and MS2 to On (checked).

Set the Multisample On/Off for MS3 and MS4 to Off (unchecked).



3. Select RomS as the Multisample Bank for MS1 and MS2.

There are three main types of Multisample Banks: **Rom**, **Ram**, and **EX \***. For each type, you can also choose between looking at mono (M) and stereo (S) Multisamples. Note that stereo Multisamples will require twice as many voices as mono Multisamples. **ROM** Multisamples are the built-in "factory" sounds, and are always available. These are organized by category, such as pianos, guitars, bells, etc.

**RAM** Multisamples include Akai, AIFF, WAVE or SoundFont files loaded from media, and samples created in Sampling mode.

The **EX\*** multisample banks are available if optional EX-USB-PCM series multisamples are loaded. The menu will show only the EX\* banks that are currently loaded.

#### 4. Press the Multisample popup for MS1.

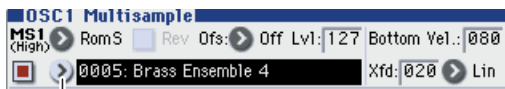

Multisample popup button

This brings up a list of Multisamples, organized by category. Use the tabs at the left of the display to browse through the different categories.

#### 5. Select a Multisample by touching its name in the list.

#### 6. Press the OK button to confirm your selection.

#### 7. Perform the same steps for MS2, selecting a different Multisample than for MS1.

Now that you've assigned Multisamples to MS1 and MS2, let's set up the velocity ranges and crossfades.

Set MS2's **Bottom Vel.** to 001, and its Xfade Range to 0.

#### 8. Set MS1's Bottom Vel. to 80.

Now, MS2 will sound when you play softly, at velocities of 79 or less—and MS1 will sound when you play harder, with velocities of 80 or more.

Next, set MS1's Xfade Range to 20, and its Curve to Linear.

#### 9. You can view this split visually in the Prog P2: OSC/Pitch– Velocity Zone page.

Notice that the graphic now shows the two ranges tapering into one another. Between 80 and 100, MS2 will fade out, and MS1 will fade in, creating a gradual velocity transition instead of a hard split.

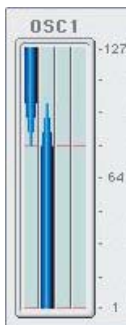

#### 10. As necessary, adjust the “Level” of the two multisamples in the Prog P2: OSC/Pitch– OSC1 Basic page.

## Copying settings between OSC1 & OSC2

Many of the Program parameters can be set differently for OSC1 and OSC2. These include all of the parameters on:

- All of the tabs on the OSC/Pitch page, except for the Pitch EG
- All of the tabs on the Filter page
- All of the tabs on the Amp/EQ page, except for EQ
- All of the tabs on the LFO page, except for Common LFO
- The AMS Mixer tabs

You can use the menu's **Copy Oscillator** command to copy these parameters from one Oscillator to another. You can even copy parameters from an Oscillator in a different Program.

This command is useful when you want to set both Oscillators to the same settings, or when you want to duplicate settings you've used before.

## Assigning a drum kit

### What is a drum kit?

Drum kits are created or edited in Global mode. To each note of the keyboard, you can assign up to four drum instrument samples, and use layering, crossfading, or velocity switching to switch between them. Then in Program mode you can make filter and amp settings, and specify effects and routing to the audio output jacks. (See “Editing Drum Kits” on page 136)

To use a drum kit in a Program, set **Oscillator Mode** to Drums, and choose one of the 144 user drum kits or the nine GM2 drum kits.

### Selecting a drum kit

#### 1. Access the Prog P1: Basic/DT/Ctrls– Program Basic page.

#### 2. Set “Oscillator Mode” to Drums.



#### 3. Select a drum kit in the Prog P2: OSC/Pitch– OSC1 Basic page.

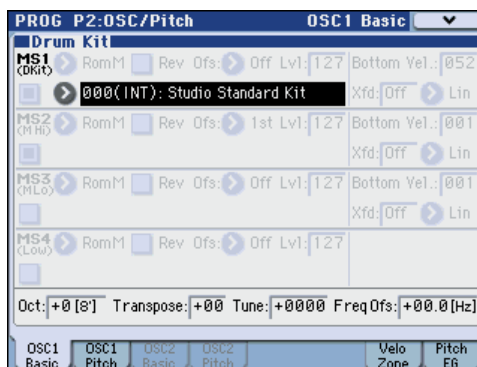

#### 4. Specify the basic pitch of the oscillator. For a drum kit, set “Octave” to +0 [8].

## Using LFOs and Envelopes (EGs)

### Using LFOs

Each Oscillator has two LFOs: LFO1 and LFO2. There is also a single Common LFO, shared by both Oscillators. While LFO1 and LFO2 are separate for each voice, the Common LFO is shared by all voices in the Program. This makes it useful when you want all of the voices to have an identical LFO effect.

You can use these LFOs to modulate many different Program parameters, including:

- Pitch (for vibrato)
- Filters (for wah effects)
- Volume (for tremolo)
- Pan (for auto-panning)

The LFOs can modulate many other parameters, in addition to those listed above.

### Using the basic LFO

1. Access the Prog P5: LFO- OSC1 LFO1 page.

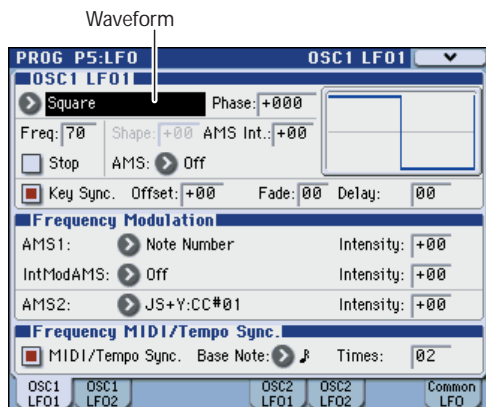

2. Select the Waveform parameter.
3. Use the Inc  $\Delta$  and Dec  $\nabla$  switches to scroll through the different waveforms, and look at their shapes in the graphic display.

There are a number of waveforms to choose from. Each are suited to different applications:

**Triangle** and **Sine** are the classic LFO shapes for vibrato, tremolo, panning, and filter wah effects.

**Square** is useful for gated filter and amp effects, and creates a police siren effect when modulating pitch.

The **Guitar** waveform is designed especially for guitar vibrato, since it bends only upwards from the base value.

**Saw** and **Exponential Saw Down** are good for rhythmic filter and amp effects.

**Random 1 (S/H)** creates the classic sample-and-hold effect, which is great for modulating a resonant filter.

4. After looking at the different waveforms, select **Triangle**.
5. Select the Shape parameter, and use the VALUE slider to move through its different settings, from -99 to +99.

Notice how the shape of the waveform becomes more curved, and how -99 emphasizes the lower part of the shape, and +99 emphasizes the upper part.

6. Select the Phase parameter, and use the VALUE slider to sweep through its range of values.

Notice how the waveform shifts from side to side. Among other things, this lets you offset the LFOs from one another in time, which can create interesting organic effects.

7. Use the Freq (Frequency) parameter to set the speed of the LFO.
8. Use the Fade and Delay settings to control the way the LFO sounds at the beginning of the note.

For more information on LFOs, please see "PROG P5: LFO" on page 66 of the Parameter Guide.

All of these parameters control the way that the LFO itself works. In order for the LFO to actually affect the sound, you can use the dedicated LFO routings on the Filter, Pitch, and Amp pages, or use the LFOs as AMS sources for a wide variety of parameters.

### Frequency Modulation

AMS can be used to vary the LFO speed. This lets you change the LFO speed by operating a controller, or by the EG or Keyboard Track settings.

### Frequency MIDI/Tempo Sync.

If **Frequency MIDI/Tempo Sync.** is checked, the **Frequency** setting will be ignored, and the LFO will synchronize to the system tempo, as set by the TEMPO knob or external MIDI clocks.

This lets you produce vibrato, wah, auto-pan, or tremolo effects that lock to KARMA, Drum Track, the internal sequencer, or external MIDI sequencers.

## EGs (Envelope Generators)

An envelope creates a modulation signal by moving from one level to another over a specified time, and then moving to another level over another period of time, and so on.

The Program includes three EGs, for Pitch, Filter, and Amp. These produce time-varying changes in pitch, tone, and volume respectively. They can also be used to modulate a number of other Program parameters via AMS.

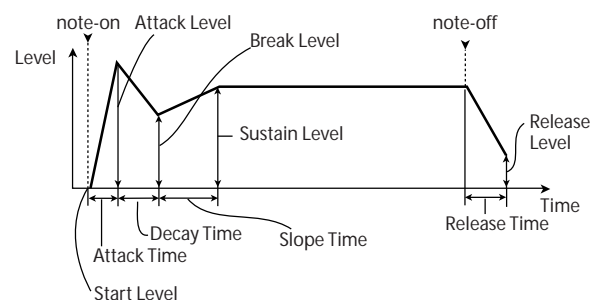

## Using Alternate Modulation (AMS) and the AMS Mixers

### Alternate Modulation

**AMS (Alternate Modulation Source)** refers to any of the assignable modulation sources in M3, including:

- KYBD-61/73/88 controllers such as the joystick or ribbon controller
- Built-in physical controllers, such as the Real-Time Sliders
- Incoming MIDI controllers, or MIDI controllers generated by KARMA or the X-Y control
- Modulators such as the Filter, Pitch, and Amp EGs, the LFOs, or the AMS Mixers

**Intensity** is a parameter that sets the degree (speed, depth, amount etc.) to which AMS will control the modulation.

A number of frequently-used modulation routings, such as using the KYBD-61/73/88's joystick to vary the pitch, are provided as additional, dedicated routings, separate from AMS.

Note that not all AMS sources may be available for some modulation destinations.

For details on alternate modulation and AMS, please see below.

- “Alternate Modulation Sources (AMS)” on page 587 of the Parameter Guide
- “Creating Vibrato” on page 56
- “Pitch EG” on page 56
- “Filter EG” on page 58
- “LFO modulation” on page 59
- “Pan AMS and Intensity” on page 61
- “LFO1/2” on page 61

### Using the AMS Mixers

The AMS Mixers combine two AMS sources into one, or process an AMS source to make it into something new.

For instance, they can add two AMS sources together, or use one AMS source to scale the amount of another. You can also use them to change the shapes of LFOs and EGs in various ways, modify the response of realtime controllers, and more.

The AMS Mixer outputs appear in the list of AMS sources, just like the LFOs and EGs.

This also means that the original, unmodified inputs to the AMS Mixers are still available as well. For instance, if you use LFO 1 as an input to a AMS Mixer, you can use the processed version of the LFO to control one AMS destination, and the original version to control another.

Finally, you can cascade the two AMS Mixers together, by using AMS Mixer 1 as an input to AMS Mixer 2.

### Adding two AMS sources together

AMS mixers will do different things depending on their **Mixer Type** setting. The **A+B** setting merges two AMS sources into one. This can be handy when you need to add one more modulation source to a parameter, but you've already used up all of the available AMS slots.

For instance, let's say that you're using an LFO to modulate Resonance, and then you decide that it would be interesting to scale that parameter with an EG as well. Resonance has only a single AMS input, but you can easily merge the LFO and the EG together using the A+B AMS Mixer:

1. **Assign the LFO to AMS A.**
2. **Assign the EG to AMS B.**
3. **Assign the AMS Mixer as the Filter Resonance AMS.**

*AMS Mixer A+B example*

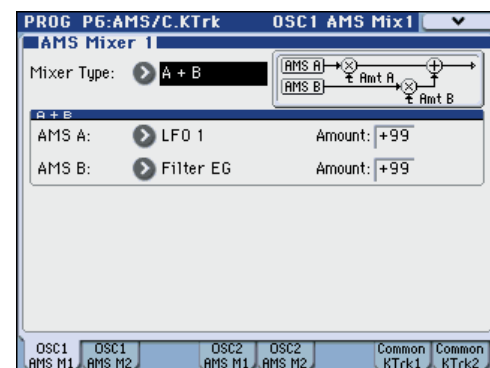
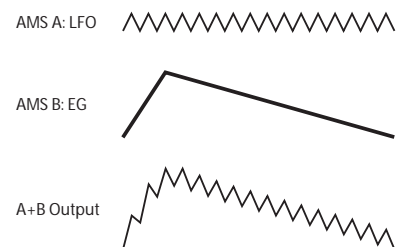

### Scaling one AMS source with another

When the **Mixer Type** is set to **Amt A x B**, the AMS mixer uses the AMS B input to scale the amount of AMS A. For instance, you can control the amount of the LFO1 with the Filter EG, or control the amount of the Pitch EG with the ribbon.

*AMS Mixer Amt Ax B example*

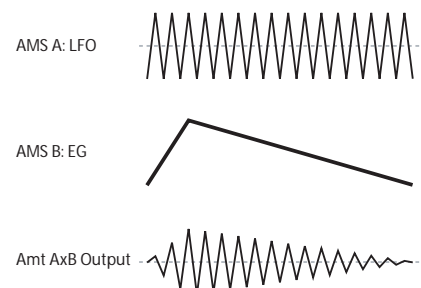



## Smoothing

The Smoothing **Mixer Type** smooths out the AMS input, creating more gentle transitions between values. You have separate control of the amount of smoothing during the attack (when the signal is increasing) and decay (when it's decreasing).

Low settings provide subtle controller smoothing, creating more gradual aftertouch, for instance. Higher settings create auto-fade effects, transforming a quick gesture into a longer fade-in and/or fade-out event.

Smoothing can also be used to alter the shape of programmable mod sources, such as LFOs and EGs. For instance, you can turn a “blip” into a simple envelope shape, as shown below.

### AMS Mixer Smoothing examples

Original AMS A:      Smoothing with Long Attack and Short Release:



Smoothing with Short Attack & Long Release:



## More AMS Mixer features

There are more mixer **Types**, including **Offset**, **Shape**, and **Quantize**, which offer even more possibilities for creative programming.

For details, please see “6-1: OSC1 AMS Mix1” on page 70 of the Parameter Guide.

## Tips for using AMS

When making settings for alternate modulation, think of the effect that you wish to produce, what type of modulation will be necessary to produce that effect, and what parameter of the oscillator, filter, or amplifier needs to be controlled.

Next, select a source (**AMS**) and set the **Intensity**. If you proceed logically in this way, you will achieve the desired effect.

For example in a guitar sound program where you want to use the joystick to control the feedback, you would make assignments so that the joystick controls the filter frequency and resonance.

## Controller Setup page

For each program, the function of Realtime Control sliders 5-8 and the KYBD-61/73/88 SW1 and SW2 switches can be assigned in the Prog P1: Basic/DT/Ctrl- Controllers Setup page.

For details, please see “Setting the functions of SW1 and SW2” on page 198.

## Controlling Pitch

### Pitch bend

The **JS (+X)** and **JS(-X)** settings specify the amount of pitch change (in semitones) that will occur when MIDI pitch bend messages are received or when the joystick is moved to left or right. A setting of **+12** allows the pitch to be controlled a maximum of one octave upward; a setting of **-12** allows the pitch to be controlled a maximum of one octave downward.

**Ribbon** specifies the amount of pitch change (in semitones) that will occur when MIDI control change #16 messages are received, or when you move your finger left and right on the ribbon controller. With a setting of **+12**, the pitch will be raised one octave at the far right of the ribbon controller, and will be lowered by one octave at the far left of the ribbon controller.

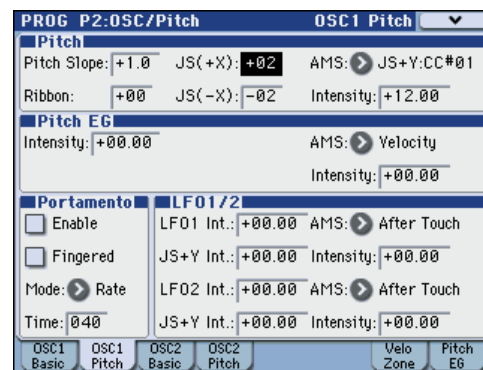

### Creating Vibrato

You can use an LFO to create vibrato.

**LFO1 Int.** or **LFO2 Int.** sets the depth to which the selected LFO will affect the pitch. With a setting of **+12.00**, vibrato will produce a maximum of  $\pm 1$  octave of pitch change.

**JS+Y Int** specifies the amount of vibrato that the LFO will produce when the joystick is pushed away from yourself.

**Intensity** (AMS Intensity) specifies the depth of vibrato that will be applied by the LFO when modulated by the selected AMS (Alternate Modulation Source). For example, if **LFO1 AMS** is set to **After Touch** and you set an appropriate value for **Intensity**, vibrato will be applied when you apply pressure to the keyboard or when MIDI aftertouch messages are received.

### Pitch EG

When the **Intensity** value is set to **+12.00**, the pitch EG specified in the Pitch EG page will produce a maximum of  $\pm 1$  octave of pitch change.

To realistically simulate the slight change in pitch that occurs when a string is plucked or at the attack of a brass or vocal sound, you can use the EG to create a subtle change in pitch at the attack.

## Portamento

Portamento makes the pitch change smoothly when you play the next note before releasing the previous note.

The **Time** parameter controls how long it takes the pitch to change. As this value is increased, the pitch will change over a longer time. With a value of **000**, there will be no portamento.

You can turn Portamento on and off via SW1 or SW2, by assigning them to **Porta.SW CC#65**.

## Using Filters

The filters allow you to diminish or emphasize specified frequency areas of the sound.

**The tone of the sound will depend significantly on the filter settings.**

The basic filter settings, including the routing, type, cutoff frequency, and resonance, are set on the P3-1: Filter1 or P3-2: Filter2 page.

## Filter Routing

Each oscillator has two filters, Filter A and Filter B. The **Filter Routing** parameter controls whether one or both of the filters are used, and if both are used, it controls how they are connected to each other.

The **Single** routing uses only Filter A as a single 2-pole, 12dB/octave filter (6dB for Band Pass and Band Reject).

The **Serial** routing uses both Filter A and Filter B. The oscillator first goes through Filter A, and then the output of Filter A is processed through Filter B.

**Parallel** also uses both Filter A and Filter B. The oscillator feeds both filters directly, and the outputs of the two filters are then summed together.

The **24dB(4Pole)** routing merges both filters to create a single 4-pole, 24dB/octave filter (12dB for Band Pass and Band Reject). In comparison to Single, this option produces a sharper roll-off beyond the cutoff frequency, as well as a slightly more delicate resonance. Many classic analog synths used this general type of filter.

*Serial and Parallel Routing*

Serial

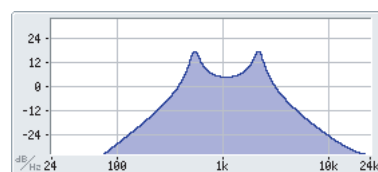

Parallel

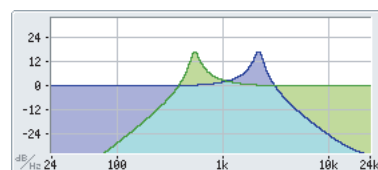
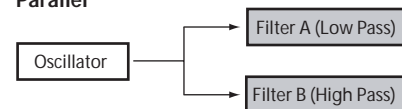

## Filter Types

This selects the parts of the sound which will be affected by the filter, as described below. With the Serial and Parallel routings, you can independently set the types for Filter A and Filter B.

The filters will produce very different results depending on the selected filter type.

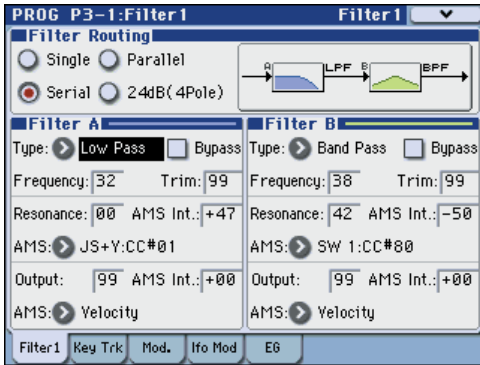

**Low Pass (12dB/oct):** This cuts out the parts of the sound which are **higher** than the cutoff frequency. Low Pass is the most common type of filter, and is used to make bright timbres sound darker.

**High Pass (12dB/oct):** This cuts out the parts of the sound which are **lower** than the cutoff frequency. You can use this to make timbres sound thinner or more buzzy.

**Band Pass (6dB/oct):** This cuts out all parts of the sound, both highs and lows, except for the region around the cutoff frequency. Since this filter cuts out both high and low frequencies, its effect can change dramatically depending on the cutoff setting and the oscillator's multisample.

With low resonance settings, you can use the Band Pass filter to create telephone or vintage phonograph sounds. With higher resonance settings, it can create buzzy or nasal timbres.

**Band Reject (6dB/oct):** This filter type—also called a notch filter—cuts only the parts of the sound directly around the cutoff frequency. Try modulating the cutoff with an LFO to create phaser-like effects.

### Filter Types and Cutoff Frequency

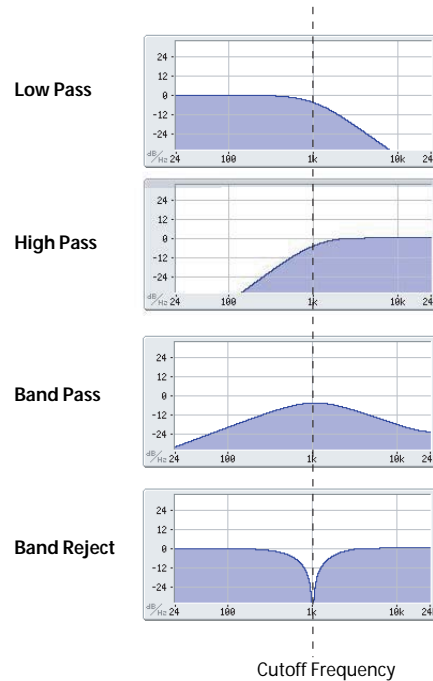

### Resonance

Resonance emphasizes the frequencies around the cutoff frequency, as shown in the diagram below.

When this is set to 0, there is no emphasis, and frequencies beyond the cutoff will simply diminish smoothly.

At medium settings, the resonance will alter the timbre of the filter, making it sound more nasal, or more extreme. At very high settings, the resonance can be heard as a separate, whistling pitch.

To make the resonance track the keyboard pitch, please see “Key Follow,” on page 50 of the Parameter Guide.

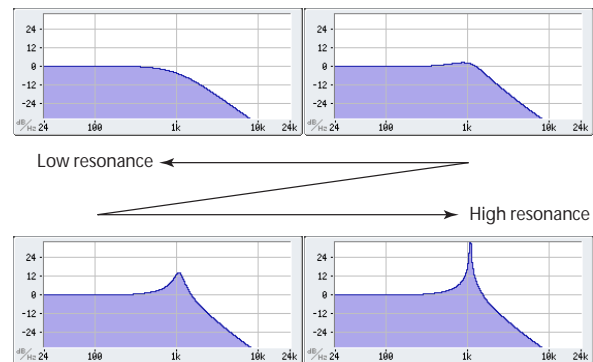

## Modulating the filters

You can modulate the filter cutoff frequency using the Filter EG, the LFOs, keyboard tracking, and other built-in and MIDI controllers. This is a great way to add a rich variety of tonal change to the sound.

### Filter EG

The Filter EG is a multi-stage envelope, which you can use to modulate the filter (naturally!) as well as other Program parameters. The EG itself is set up on the EG tab; the way that it affects the filters is controlled by the

parameters described below, on the Filter1/2-Modulation page:



The **Intensity to A** and **Intensity to B** settings control the basic amount of EG modulation for filter frequencies A and B, respectively, before other modulation.

The **Velocity to A** and **Velocity to B** settings let you use velocity to scale the amount of EG modulation.

The **AMS** setting selects a AMS modulation source to scale the amount of the Filter EG applied to Filters A and B. The two filters share a single AMS source, with separate intensity **Into A** or **to B** settings.

## LFO modulation

You can modulate the filter via LFO1, LFO2, and the Common LFO. Among other applications, LFO modulation of the filter can produce the classic “auto-wah” effect.

The Filter1/2- LFO Mod. page lets you set up the following parameters separately for each LFO:

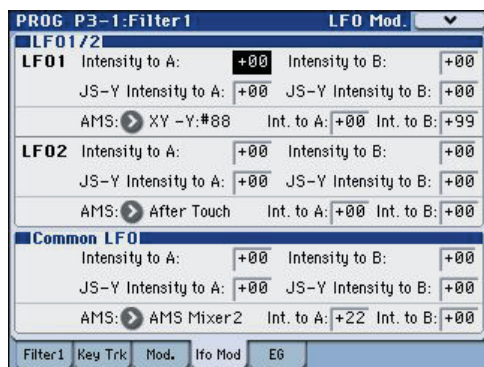

**Intensity to A** and **Intensity to B** specify how much the LFO changes the tone.

**JS-Y Intensity to A** and **JS-Y Intensity to B** specify the depth of the wah effect produced by the LFO when the KYBD-61/73/88's joystick is moved toward yourself, or when CC#2 is received.

The **AMS** setting selects a AMS modulation source to scale the amount of the LFO applied to Filters A and B. The two filters share a single AMS source, with separate intensity settings.

For example if, **AMS** is set to **After Touch**, applying pressure to the keyboard produces an “auto-wah” effect.

## Keyboard Track

Most acoustic instruments get brighter as you play higher pitches. At its most basic, keyboard tracking recreates this effect by increasing the cutoff frequency of a lowpass filter as you play higher on the keyboard. Usually, some amount of key tracking is necessary in order to make the timbre consistent across the entire range.

The M3 keyboard tracking can also be much more complex, since it allows you to create different rates of change over up to four different parts of the keyboard. For instance, you can:

- Make the filter cutoff increase very quickly over the middle of the keyboard, and then open more slowly—or not at all—in the higher octaves.
- Make the cutoff increase as you play lower on the keyboard.
- Create abrupt changes at certain keys, for split-like effects.

## How Key Track works: Keys and Ramps

The keyboard tracking works by creating four ramps, or slopes, between five keys on the keyboard. The bottom and top keys are fixed at the bottom and top of the MIDI range, respectively. You can set the other three keys—named Low Break, Center, and High Break—to be anywhere in between.

The four Ramp values control the rate of change between each pair of keys. For instance, if the Low-Center Ramp is set to 0, the value will stay the same between the Low Break key and the Center key.

You can think of the resulting shape as being like two folding doors attached to a hinge in the center. At the Center key (the main hinge), the keyboard tracking has no effect. The two folding doors swing out from this center point to create changes in the higher and lower ranges of the keyboard.

### Keyboard Track Shape and Intensity

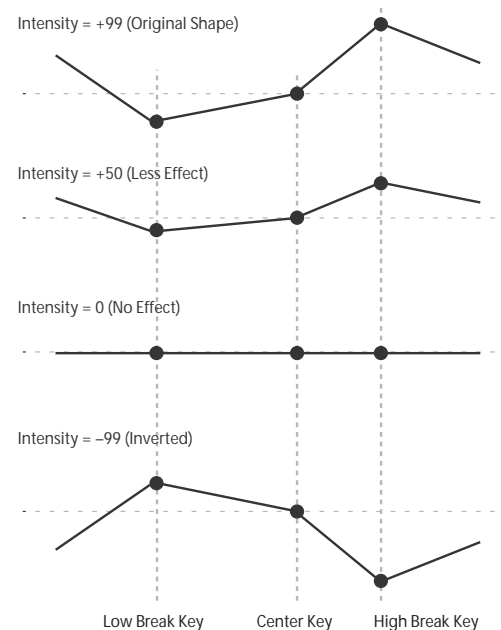

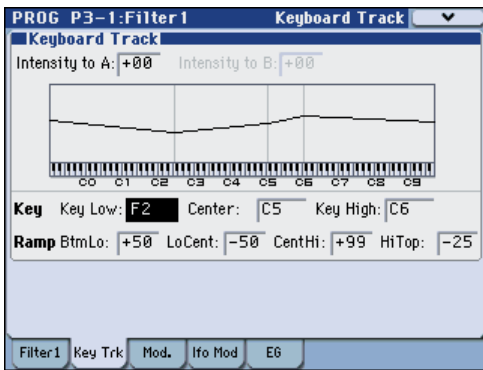

**Intensity to A** and **Intensity to B** adjust the effect that keyboard tracking will have on filters A and B. For details, please see “3-1-2: Keyboard Track,” on page 49 of the Parameter Guide.

### AMS Modulation

In addition to the EG, LFOs, and Key Track, you can use two AMS sources to modulate the filters. For instance, you could use the ribbon to change the brightness.

## Using the Amp section

The Amp section includes controls for volume, pan, and the driver circuit.

You can control the volume using the Amp EG, LFO 1/2, Key Track, and velocity, along with other AMS sources.

Each Oscillator has its own Amp section: Amp1 for OSC1, and Amp2 for OSC2.

## Background - what does “Amp” mean?

Different sounds have characteristic shapes to their volume levels.

For example, the volume of a piano note begins at a high volume the instant you play the note, and then decreases gradually.

The volume of an organ note, on the other hand, remains constant as long as you continue pressing the key.

The volume of a note on a violin or wind instrument can be varied during the note by the musician (i.e., by regulating the amount of pressure on the bow or the force of the breath).

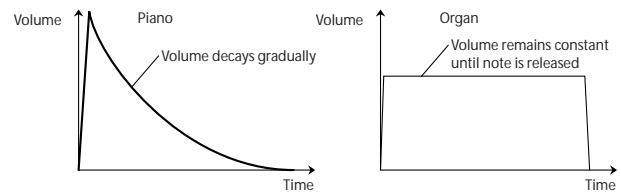

## Pan

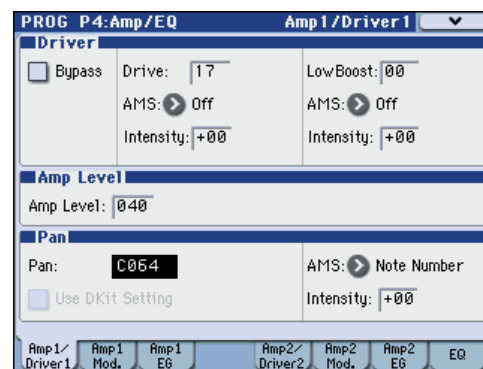

### Pan

The main **Pan** parameter controls the stereo position after the signal has passed through the oscillator, filter, and amp.

Normally you’ll set this to **C064**, so that the sound is centered equally between the left and right speakers.

To create a stereo effect when **Oscillator Mode** is set to **Double**, set the Amp1/Driver 1 page **Pan** to L001, and the Amp2/Driver2 page **Pan** R127. This will make OSC1 go to the left speaker, and OSC2 go to the right speaker.

With a setting of **Random**, the pan will change randomly each time you play a note on M3, producing an interesting effect.



## Pan AMS and Intensity

**Intensity** specifies the depth of the pan modulation from the selected AMS source.

If you set **AMS** to **Note Number**, the pan will change according to the keyboard position of each note played. With a setting of **LFO1** or **2**, the sound will sweep from side to side, creating an auto-pan effect. Other settings allow you to move the oscillator pan by using a real-time controller, an envelope, or other modulation sources.

## Pan - Use DKit Setting

**Use DKit Setting** applies when **Oscillator Mode** is set to **Drums**.

If this is **checked**, the Program can use a different pan position for each drum sound, as specified by the Drum Kit. If this is **unchecked**, all drum sounds will use the Program's pan position.

The factory presets and GM drum kits use individual pan positions for the different drums, so normally it's best to leave this checked.

## Amp modulation

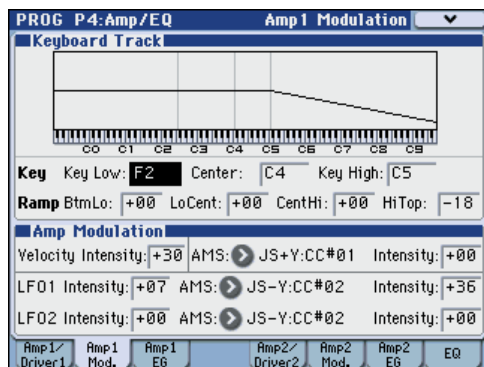

The basic volume level is set by the **Amp Level** parameter. You can then alter this using the modulation sources below:

## Keyboard Track

This lets you vary the volume relative to the note you play.

For details, please see "Keyboard Track" on page 59.

## Amp Modulation

**Velocity Intensity** is used by most programs to decrease the volume of softly played notes and increase the volume of strongly played notes, and the Amp Modulation parameter adjusts the depth of this control.

Normally you will set Amp Modulation to positive (+) values. As this setting is increased, there will be greater volume difference between softly played and strongly played notes.

## LFO1/2

Specifies how the LFO's will produce cyclic changes in volume (tremolo effect).

The volume will be affected by the LFO(s) for which you set an **LFO1 Intensity**, **LFO2 Intensity** value.

**Intensity** (AMS Intensity) adjusts the depth by which the tremolo effect produced by the LFO will be affected when you assign an **AMS** (LFO1 AMS, LFO2 AMS).

For example if you set **AMS** to **JS-Y: CC #02**, tremolo will be applied when you move the KYBD-61/73/88's joystick of M3 toward yourself, or when CC#02 is received.

## Amp EG

The Amp EG lets you control how the volume changes over the course of a note.

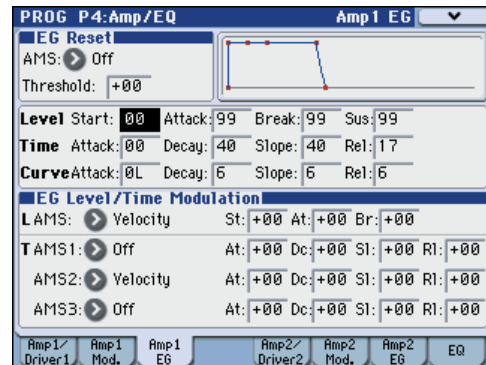

Every instrument has its own characteristic volume envelope. This is part of what gives each instrument its identifiable character.

Conversely, by changing the volume contour—for instance, applying a string-like Amp EG curve to an organ multisample—you can produce interesting and unusual sounds.

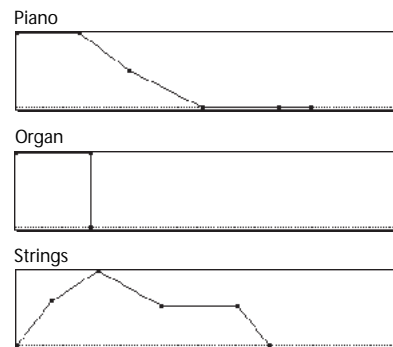

## Drive

The Drive circuit adds saturation and overdrive to the sound, for everything from subtle fattening to drastic distortion. Unlike an overdrive effect, Drive processes each voice individually, so the timbre stays the same regardless of how many voices are being played.

The two main parameters, **Drive** and **Low Boost**, work together to create the overall effect.

**Drive** controls the amount of edge and bite in the timbre. Low settings will produce mild saturation, and higher settings create more obvious distortion.

Often, it's useful to increase the **Low Boost** along with the **Drive**.

*Note:* even when the **Drive** amount is set to 0, the **Drive** circuit still affects the timbre. If your goal is a completely pristine sound, use the **Bypass** control instead.

**Low Boost** is a special low-frequency EQ which controls the body character of the sound. The specific EQ frequencies affected will change with the **Drive** setting.

Higher amounts increase the bass boost, and will also intensify the effect of the **Drive** parameter.

## X-Y control settings

For details about turning X-Y control on/off or recording X-Y motion, please see “X-Y controller” on page 43.

### What does X-Y control?

Modulation generally works by moving a single control, like a slider, in a straight line. At one end of the control, the modulation is at its minimum; at the other end, it's at its maximum.

X-Y control is a little different. It works by moving around a point on a two-dimensional plane, both left-right and up-down.

You can think of this point as being positioned on two different lines at once: a left-right line (the X axis), and an up-down line (the Y axis).

The X-Y position consists not of a single value (as a slider) but of two values (X-value and Y-value). Refer to the following illustration.

*X-Y position and X and Y axis values*

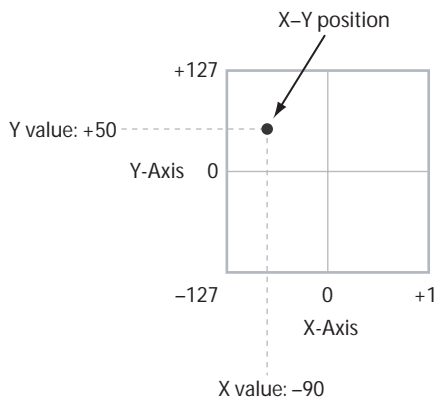

You can move the position of the point not only by directly moving the point in the display (X-Y Mode), but also automatically using X-Y motion, as shown below.

*X-Y motion moving the X-Y position*

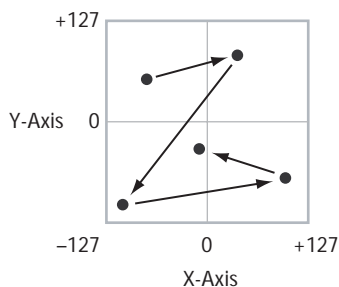

## Volume Control and CC Control

The X-Y control does two main things: it can control the relative volume of the two Oscillators in Program mode (or of up to 16 Programs at once in Combination mode).

The other is to generate CC (MIDI control change) messages that will modify the program or effect parameters to change the sound.

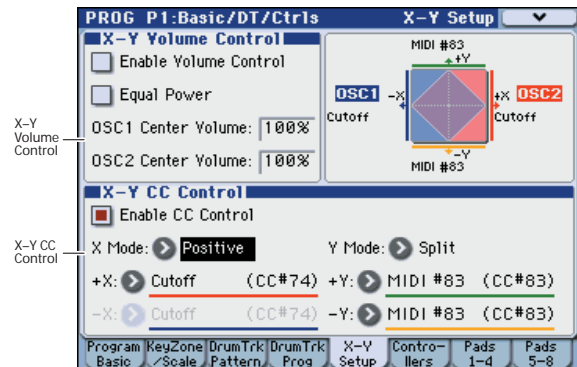

### X-Y control and MIDI

The X-Y control features interact with MIDI in two different ways: through the X-Y Mode, and through the X-Y CC Control.

The X-Y Mode sends and receives two MIDI controllers: one for the X axis, and the other for the Y axis. In Global mode, you can assign these to any MIDI CC numbers you like. The defaults are CC#118 for the X axis, and CC#119 for the Y axis. X-Y mode (or X-Y motion) and its MIDI control changes will control the X-Y position.

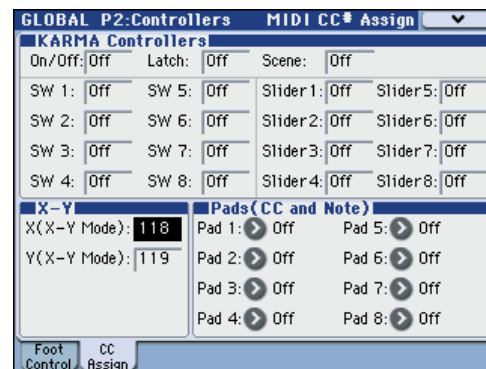

The **X-Y CC Control**, on the other hand, is generated by the X-Y position. Normally, this will only affect internal sounds and effects. If you like, however, you can also enable a Global parameter to send these generated CCs to external MIDI devices.

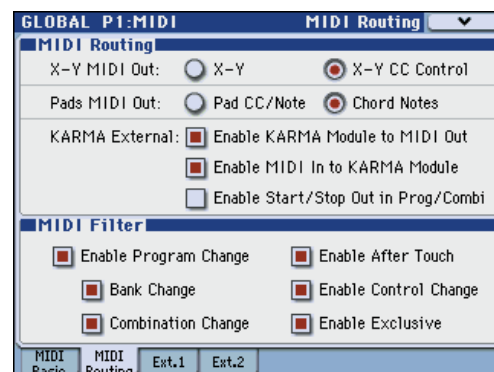

---

## KARMA settings

Based on your keyboard playing or on the note data received from MIDI IN, the KARMA function automatically generates a diverse variety of phrases or patterns, such as guitar or keyboard backing riffs, bass phrases, or drum patterns. You can use the KARMA sliders and the KARMA switches to freely modify these phrases or patterns.

The M3 is preloaded with numerous programs and combinations that cover a wide range of instruments, performance techniques, and musical styles, and which take full advantage of the KARMA function.

For more about the KARMA function, please see page 163.

---

## Drum Track settings

While you perform using a program, you can use the M3's rich variety of drum patterns to play high-quality drum programs.

Playing along with Drum Track patterns is often a useful way to come up with new phrases.

For more about the Drum Track function, please see page 185.

---

## Effects

Effects are covered in their own section of the manuals, so we won't go into too much detail here.

---

### Insert Effects

Insert Effects let you send either individual Oscillators or the entire Program through up to 5 effects, in series. You can use any type of effects, from distortions and compressors to choruses and reverbs. The Insert Effect output can be routed to the (MAIN) L/MONO and R jacks, as well as to each INDIVIDUAL jack.

Two double-size effects (154: St.Mltband Limiter – 170: Early Reflections) can be used in IFX1–4, plus one normal effect for a maximum of three effects. You can also use one double-size effect and up to three normal effects for a total of up to four effects.

For details, please see "Insert effects" on page 155.

---

### Master Effects

There are two Master Effects, which are accessed through Sends 1 and 2. The master effects are suitable for use with effects such as reverb or delay. If you choose a double-size effect, you'll be able to use only one effect in master effect 1. When using a double-size effect, master effect 2 cannot be used.

For details, please see "Master effects" on page 156.

---

### Total Effect

The Total Effect is dedicated to processing the main L/R outputs. The Total Effect is suitable for use with effect types that are applied to the entire mix, such as compressor, limiter, or EQ.

You can use effects other than double-size effects.

For details, please see "Total Effect" on page 157.

---

## Automatically importing a Program into Sequence mode

The Auto Song Setup feature copies the current Program or Combination into a Song, and then puts the M3 in record-ready mode.

If inspiration for a phrase or song strikes you while you're playing, you can use this function to start recording immediately. To do so:

1. **Hold down the ENTER switch and press the SEQUENCER REC/WRITE switch.**

The Setup to Record dialog box will open and ask "Are you sure?"

2. **Press OK.**

You will automatically enter Sequencer mode, and will be in the record-ready state.

3. **Press the START/STOP switch to start the sequencer and begin recording.**

With the default settings, your program performance will be recorded on MIDI track 01, and the Drum Track performance on track 10.

# Playing and editing Combinations

## About the M3's combinations

Combinations, let you split and layer up to 16 Programs at once.

A Combination is made up of 16 Timbres. Each Timbre has a Program, along with parameters for key and velocity zones, mixer settings, MIDI channel and controller filtering, and so on.

As with Programs, each Combination has five insert effects, two master effects, and one total effect, for shaping and transforming the sounds of the individual Timbres.

This section of the manual takes a quick look at playing Combinations, including tours of the front-panel controllers and basic editing techniques.

## Playing combinations

### Selecting Combinations

There are several different ways to select Combinations. Each one is convenient in a different way:

- Using "Combination Select" and the VALUE controllers  
Choose "Combination Select," and then use the VALUE controllers to select a program.
- Using the Bank/Combination Select menu  
In the display, press the "Combination Select" popup button, and choose from the menu organized by bank.
- Using the Category/Program Select menu  
In the display, press the "Category Select" popup button, and choose from the menu organized by categories such as piano or drums.
- Using a foot-switch lets you change Combinations even while both hands are busy playing on the keyboard - convenient for live applications
- MIDI program change messages let you select Combinations remotely, from either -a MIDI sequencer or an external MIDI controller

See below for details.

### Selecting a program using "Combination Select" and the VALUE controllers

1. Press the MODE COMBI switch. (The LED will light.)  
(Refer to the illustration below for the switches.)  
You will enter Combination mode.
2. Access the Combi P0: Play- Program T01-08 page.  
This is shown in the top line of the display.

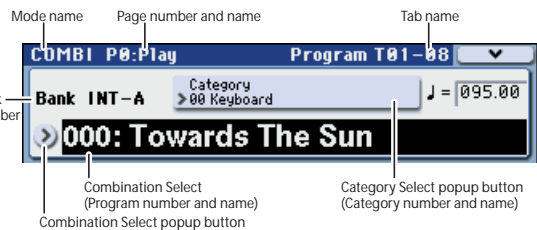

If a different page is shown, press the EXIT switch several times to move to the Combi P0: Play- Program T01-08 page.

3. Make sure that "Combination Select" is selected.  
If it is not, press "Combination Select" in the display to highlight it.

4. Select the program you want to play.

You can use the following methods to select a program.

- Use the  $\Delta$  or  $\nabla$  switches.
- Turn the VALUE dial.

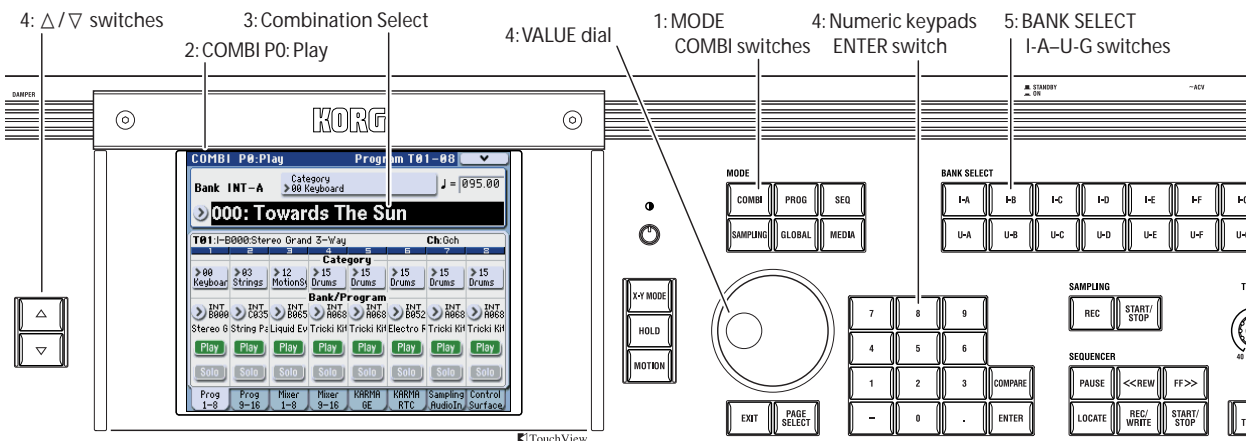



- Use numeric keys 0–9 to enter the program number, and press the ENTER switch.
5. Press a BANK SELECT I-A-U-G switch to switch banks.

When you select a different Bank, the switch’s LED will light, and the selected bank will appear on the left side of the display.

For example, to select bank INT-B, press the BANK SELECT I-B switch. The I-B switch will light, and the name Bank INT-B will appear in the left of the display.

### Auditioning the sound

To hear the combination you selected, play the KYBD-61/73/88 or a MIDI-connected keyboard. Alternatively, you can strike the M3-M’s pads to hear the program.

### Overview: Combination Banks

With the factory settings, the M3 contains 384 preloaded combinations that are GM2 compatible. In addition to these you can store sounds that you create, as well as optional sound libraries, giving you a total of 1,792 combinations.

Combinations are organized into fourteen banks as shown in the following table.

Combination bank contents

Bank	Combi. No.	Explanation
INT-A...C	000...127	Factory Programs.
INT-D...G, USER-A...G	000...127	Initialized Programs.

For details on the factory-set combinations, refer to the “Voice Name List” on the included CD-ROM.

### Selecting by Bank/Combination Select menu

You can select Combinations from a list organized by Combination bank.

- Press the Combination Select popup button to access the menu and make your selection.

The selection method is the same as in “Selecting by Bank/Program Select menu” on page 38. Refer there for details.

Bank/Combination Select menu

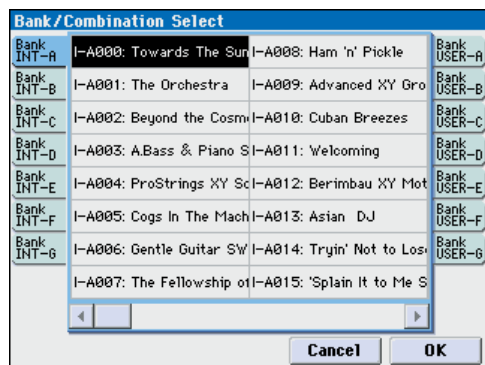

### Selecting by Category/Combination Select menu

You can select Combinations from within a category, such as keyboard, organ, bass, and drums.

When shipped from the factory, the preloaded Combinations are organized into 16 categories, each with several sub-categories. There are also 2 more categories, initially named User 16 and User 17, which you can use and rename as desired.

- Press the Category Select popup button to access the menu and make your selection.

The selection method is the same as in “Selecting by Category/Program Select menu” on page 39. Refer there for details.

Category/Combination Select menu

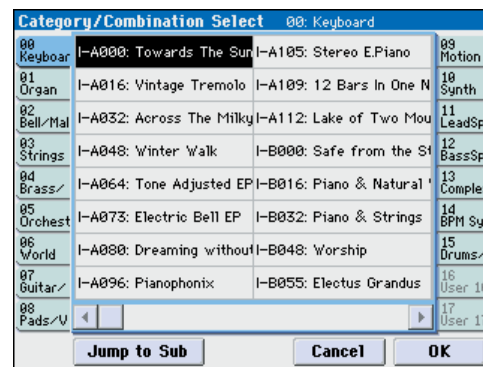

### Selecting Combinations using a footswitch

You can select Combinations by using a foot switch connected to the ASSIGNABLE SWITCH jack. By assigning the appropriate function, you can increment or decrement the combination number in steps of one.

Combinations without using your hands—great for quick Program changes in live performance situations.

For details, please see “Using a footswitch to select Programs” on page 39.

### Selecting Combinations from MIDI

You can send MIDI Program Change messages to M3 from external MIDI devices, such as DAW software or other MIDI controllers. In conjunction with MIDI Bank Select, you can use these to select any Combination from all 14 Banks.

If you use the included “M3 Plug-In Editor” as a plug-in inside your DAW software, you’ll be able to easily select M3 programs or combinations from a list within your DAW. For details, refer to the included “M3 Editor/Plug-In Editor Manual” (PDF).

### Transmit/receive MIDI channel settings

The Combination will change when the M3 receives a program change on a channel that matches the global MIDI channel.

However, this is affected by the Global P1: MIDI- MIDI Routing **Combination Change** setting. This setting must be checked. If this setting is unchecked, the For

details, Combination will not change; instead, the Program will change for the timbre of the matching channel.

With the factory settings, the global MIDI channel is set to channel 1. If you want to change this setting, see “MIDI-related settings for the entire M3” on page 131.

If you want to switch the Program of a timbre via MIDI, set the MIDI channel of the timbre using **MIDI Channel** in the Combi P3: Timbre Param– MIDI page. When a program change message on a MIDI channel that matched the timbre’s channel is received, the Program will change for timbres whose **Status** is INT. However, program changes for timbres are affected by the Combi P5–1: MIDI Filter1–1 page **Program Change** setting.

The result of receiving a program change on the global MIDI channel will depend on the Global P1: MIDI–MIDI Routing **Combination Change** setting.

### Bank select settings

You can specify the Program and Combination sound mapping for Bank Select control change messages (CC#0: upper byte, CC#32: lower byte). Make these settings in **Bank Map** (Global P0: Basic Setup– System Preference page). (See PG page 358)

### MIDI filter settings

You can use MIDI filters to specify whether program changes and bank select messages will be transmitted and/or received. Make these settings in the Global P1: MIDI– MIDI Routing page. (See PG page 367)

## Performing with KARMA and the Drum Track

Based on your keyboard playing or on the note data received from MIDI IN, the KARMA function automatically generates a diverse variety of phrases or patterns, such as guitar or keyboard backing riffs, bass phrases, or drum patterns. You can use the KARMA sliders and the KARMA switches to freely modify these phrases or patterns.

For more about the KARMA function, please see page 163.

The Drum Track function uses a rich variety of drum patterns to play the M3’s high-quality drum programs. You can perform along with the drum patterns, or synchronize Drum Track patterns with the phrases generated by KARMA.

For more about the Drum Track function, please see page 185.

## Using controllers to modify the sound

The M3 provides a Control Surface with sliders and switches, an X–Y control function, and pads, giving you a wide range of ways in which to vary the sound.

In addition to a keyboard, the M3 KYBD-61/73/88 provides a joystick, ribbon controller, and SW1/SW2 switches to let you control the sound.

For details, please see the corresponding explanation for Programs: “Using Controllers” on page 41.

## Easy Combination editing

You can edit any of the Combinations shipped with M3. You can create your own combinations by editing a preloaded combination, or by starting from an initialized combination.

Even without moving to the various pages for detailed editing, you can make effective changes just from within the Combi P0: Play page. You can also edit using the switches and sliders of the front panel Control Surface.

## Changing the programs within the Combination

Changing the Program assigned to each timbre (1-16) is a quick way to dramatically alter the sound of the Combination.

*Note:* Selection via MIDI program changes is limited to timbres whose status is “INT.”

## Selecting programs from the front panel and display

To change the Program assigned to a Timbre:

1. Access the Combi P0: Play– Program T01-08/T09-16 page.

In this page you can view the program assigned to each timbre 1-16, and the play/mute and solo status of each.

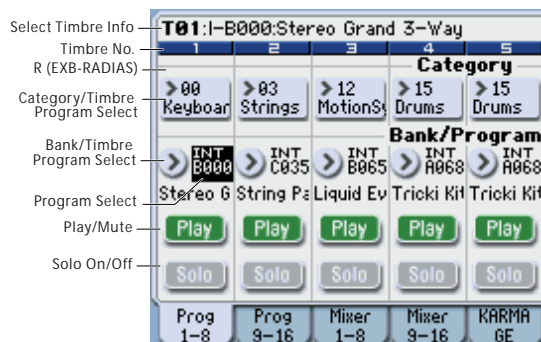

2. Use any of the following methods to select a Program for each timbre.
  - Choose **Program Select**, use numeric keys 0-9 to input the program number, and press the ENTER switch.
  - Choose **Program Select** and turn the VALUE dial, VALUE slider or use the  $\Delta/\nabla$  switches.
  - If the **Program Select** parameter is selected, the BANK I-A-U-G switches will switch program banks. (If Timbre Program Select is selected, the BANK switch LED of the program bank selected for that timbre will light.)
  - From the Bank/Program Select menu you can view and select programs by bank.
  - From the Category/Program Select menu you can view and select programs by category.

- You can transmit MIDI program changes from a connected external MIDI device. (See “Selecting Combinations from MIDI” on page 66)

*Note:*  is shown if the optional EXB-RADIAS is installed.

## Adjusting the mix

### Adjusting the volume of each timbre

1. Access the Combi P0: Play– Mixer T01-08 page.

This page shows the volume, pan, and Program assignments for all 8 Timbres.

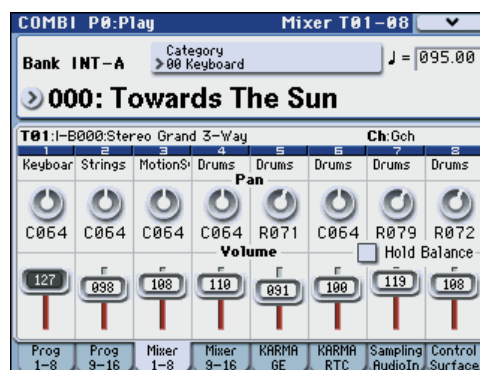

2. Select the on-display Volume slider for Timbre 1. Use  $\Delta/\nabla$ , the VALUE slider, or the numeric keypad to set the volume as desired.

If you check **Hold Balance**, moving any one of the volume sliders (volume values) will cause the volume of the other timbres to change as well, maintaining the volume balance between timbres 1-16. This is a convenient way to adjust the overall volume.

*Note:* You can use the Control Surface sliders to adjust the volume of each timbre. (See “Adjusting the volume of each timbre” on page 68)

### Adjusting the pan of each timbre

1. Access the Combi P0: Play– Mixer T01-08 page.
2. Select the on-screen Pan knob for Timbre 1, and edit its value as desired.

Timbre pan interacts with the pan stored in the Program. A setting of **C064** reproduces the Program’s oscillator pan settings. Adjusting the Timbre Pan will move the sound to left or right while preserving the pan relationship between the oscillators. A setting of **L001** is far left, and **R127** is far right.

## Simple editing using the Sliders and Switches

You can use the Control Surface to perform a variety of editing.

For example, you can adjust the volume of each timbre, or change the cutoff or resonance. You can also turn effects on/off or adjust their depth, or modify the phrases generated by KARMA.

Here we will explain how to control the volume, mute, and solo settings of each timbre. For other types of editing, refer to the explanations below.

- “Using realtime control to edit sounds or effects” on page 48
- “Editing Programs with Tone Adjust” on page 75

## Adjusting the volume, mute, and solo of each timbre

You can also edit the mixer parameters directly from the Control Surface, eight Timbres at a time.

1. Press the MIXER switch under CONTROL ASSIGN, so that the T1–8 LED lights up.

The switch has two LEDs: one for T1–8, T9–16 and INPUT. These correspond to Timbres 1–8, Timbres 9–16, and the audio inputs.

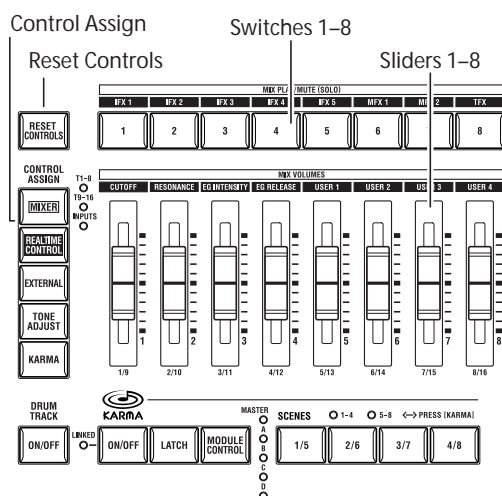

2. Access the Combi P0: Play– Control Surface page.

This page displays and reflects the control surface data. It's a convenient place to adjust the sound, since you can view the actual parameter assignments and the exact data values.

*Note:* You can use the Control Surface for control regardless of the page that is shown in the display.

3. Use sliders 1–8 to adjust the volumes of Timbres 1–8, respectively.
4. While the display shows Timbre Play/Mute, switches 1–8 will change the Play/Mute status of timbres 1–8.
5. Press the menu button to select “Panel-SW Solo Mode.”

The menu will close, and the indication of Timbre Play/Mute in the display will change to Timbre Solo.

Alternatively, you can hold down the ENTER switch and press numeric key 1 to switch between Timbre Play/Mute and Timbre Solo.

6. While the display shows Timbre Solo, switches 1–8 will turn Solo on/off for timbres 1–8.

*Note:* Solo On/Off applies to the timbres and the audio inputs.

## Saving a Combination you've edited

Once you've tweaked the sound to perfection, you'll want to save your work. To save your edits, please see “Saving your edits” on page 50, and “Writing to internal memory” on page 139.

# Detailed Editing with Combinations

You can edit the preloaded combinations (Banks A, B, and C) with which the M3 is shipped, or start with an initialized Combination to create your own original sounds.

You can use the factory Programs to create new Combinations, or use your own custom Programs. If you're in the process of editing a Program in Program mode, and you use the Program in a Combination, you'll hear the edited version in Combination mode as well.

## Overview of editing pages

P0: Play is where you select and play programs, make quick edits using the Control Surface, and adjust the KARMA settings. The other pages let you modify the sound in more detailed ways.

*Combination mode page structure*

	Page	Main content
PLAY	P0: Play	Select and play combinations. Program selection for each timbre. Pan and volume settings etc. for each timbre. Simple KARMA editing. Audio input settings and resampling settings. Editing from the control surface.

	Page	Main content
EDIT	P1: DT/XY/Ctrls	Drum Track settings. X-Y control settings. SW1, 2, and slider function settings. Pad note and velocity settings.
	P2: EQ/Option	EQ settings for each timbre. Settings for the EXB-RADIAS option.
	P3: Timbre Param	Various parameter settings for each timbre (MIDI channel, OSC selection, Pitch setting, etc.)
	P4: Zone/Delay	Key split and layer settings. (Key zone and velocity zone) Time delay from note-on to beginning of sound.
	P5-1: MIDI Filter 1	MIDI transmit/receive filter 1 settings.
	P5-2: MIDI Filter 2	MIDI transmit/receive filter 2 settings.
KARMA	P7-1: KARMA1 GE Setup	Overall KARMA settings.
	P7-2: KARMA2 Module	Settings for each KARMA module.
	P7-3: KARMA3 GE RTP	KARMA GE realtime parameter settings.
	P7-4: KARMA4 Perf	KARMA performance parameter settings.
EFFECT	P8-1: IFX Route1/1-5	Oscillator output bus and master effect send level settings. Insert effect routing, selection, and settings.
	P8-2: IFX Route2	Bus settings for oscillator output. Common FX LFO 1, 2 settings.
	P9: MFX/TFX	Master effect routing, selection, and settings. Total effect selection and settings.

For details on how to access each mode and page, please see "Basic operations" on page 22.

Sampling or resampling can be performed in Program mode. For details, please see "Sampling in Program, Combination, and Sequencer modes" on page 122.

*Combination structure and corresponding pages*

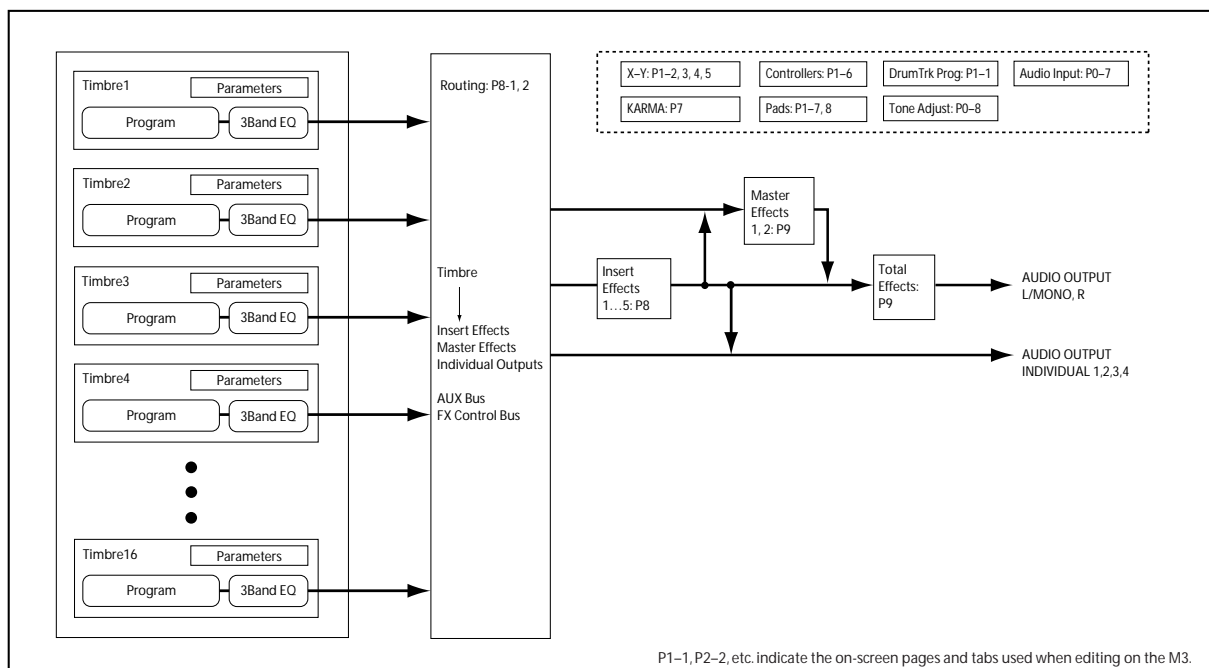

P1-1, P2-2, etc. indicate the on-screen pages and tabs used when editing on the M3.



Since you can apply the M3's internal effects to the external audio inputs, a wide range of possibilities are available. For details, please see "Using effects in Combinations and Songs" on page 157.

## A suggested approach for editing

First, select a Program for each Timbre, on the P0: Play- Program T01-08 or T09-16 page. (Note that you don't have to use all 16 Timbres!)

Next, create any desired keyboard or velocity splits, layers, or crossfades between the different Timbres. You can do this on the P4: Zone/Delay- Keyboard Zones page.

After this, adjust the volumes of the Timbres (back on the Program Select/Mixer tab), and set up any other Timbre parameters as desired.

To add finishing touches to the sound, set up the Insert, Master, and Total Effect as desired (on the P8: IFX and P9: MFX/TFX pages, respectively.) These effects can be different from those of the individual Programs in Program mode, if desired.

In addition, you can make KARMA settings (on the P7: KARMA page) and controller settings (on the P1: DT/XY/Ctrls page) to create the finished Combination.

### Soloing timbres

You can use the Control Surface's Solo function to hear the sound of each timbre by itself. For details, please see "Adjusting the volume, mute, and solo of each timbre" on page 69.

## Using COMPARE

When you're in the process of editing a sound, pressing the COMPARE switch will recall the saved version of the sound, as it was before you started editing.

1. **While editing, press the COMPARE switch (the LED will light).**

The saved sound from before you began editing will be recalled.

2. **Pressing COMPARE again returns you to the version you are editing, and the LED will go out again.**

*Note:* If you edit while the COMPARE LED is lit, the switch will again go dark and your previous edits will be lost.

### Resetting individual controls

The RESET CONTROLS switch lets you revert an individual slider, or switch to its saved setting. (See page 43)

## Layers, Splits, and Velocity Switches

Within a Combination, you can use note number and velocity to determine which Timbres will sound.

The Programs assigned to each Timbre can sound in three ways: as part of a **layer**, a **split**, or a **velocity switch**. A Combination can be set to use any one of these methods, or to use two or more of these methods simultaneously.

### Layer

Layers cause two or more Programs to sound simultaneously when a note is played.

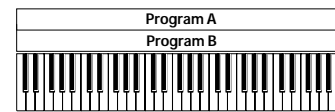

Layer:  
Two or more programs sound simultaneously.

### Split

Splits cause different Programs to sound on different areas of the keyboard.

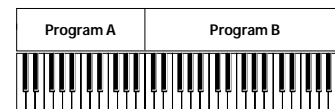

Split:  
Different programs will sound in different areas of the keyboard.

### Velocity Switch

Velocity Switches cause different Programs to sound depending on the velocity (how hard you play the notes).

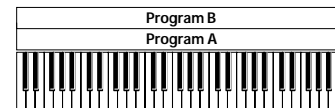

Strong ↑ Keyboard playing dynamics  
Soft ↓

Velocity Switch:  
Keyboard playing dynamics (velocity) switches between different programs.

On M3, you can use a different Program for each of up to sixteen Timbres, and combine two or more of the above methods to create even more complex setups.

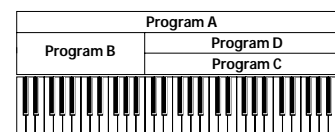

Strong ↑ Keyboard playing dynamics  
Soft ↓

Example:  
B and C/D are split. In the lower keyboard range, A and B are layered. In the higher keyboard range, C and D are switched by velocity and layered with A.

As an additional possibility, you can set the slope for a key zone or velocity zone so that the volume diminishes gradually. This lets you change a split into a keyboard crossfade, or a velocity switch into a velocity crossfade.

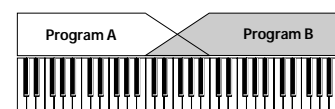

Keyboard X-Fade (keyboard crossfade):  
As you play from low notes to high notes, the volume of A will fade out, and the volume of B will fade in.

## Creating Key Splits and Layers

### Splits and Layers

Let's create a Combination which combines both splits and layers, like the diagram below:

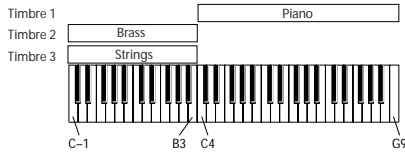

1. Access the Combi P0: Play- Program T01-08 page.
2. Select a piano sound for Timbre 1, a brass sound for Timbre 2, and a strings sound for Timbre 3.
3. Access the P3: Timbre Param- MIDI T01-08 page.
4. For Timbres 1-3, set Status to INT and MIDI Channel to Gch (the Global Channel).



5. Access the P4: Zone/Delay- Key Z T01-08 page.
6. Set Timbre 1's Top Key to G9, and its Bottom Key to C4.

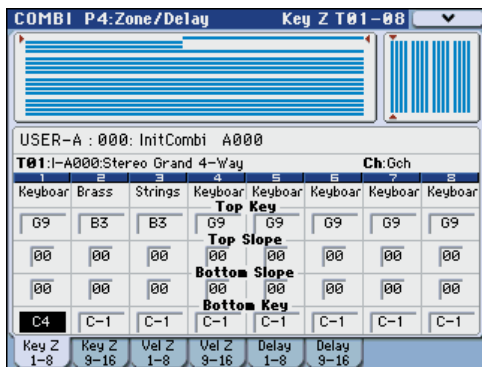

You can also enter a note value by selecting the parameter and then playing a note on the keyboard while holding down the ENTER switch.

7. Set Timbres 2 and 3 to a Top Key of B3, and a Bottom Key of C-1.

### Key Zone Slope

In addition to "hard" splits, in which the sound changes abruptly, you can use the Slope parameters to gradually fade a sound in or out over a range of keys.

In the example above, you could set the Bottom Key of timbre 1 to G3, and set the Top Key of timbre 2 to G4, so that these two timbres overlap.

Next, if you set the **Bottom Slope** of timbre 1 to 12, and set the **Top Slope** of timbre 2 to 12, the sound will change gradually instead of changing suddenly.

## Creating Velocity Switches

Next, let's create a simple velocity switched Combination, like the diagram below:

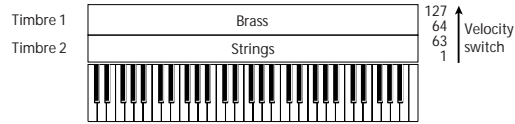

1. Access the Combi P0: Play- Program T01-08 page.
2. Select a brass sound for Timbre 1, and a strings sound for Timbre 2.
3. Access the P3: Timbre Param- MIDI T01-08 page.
4. For Timbres 1 and 2, set Status to INT and MIDI Channel to Gch (the Global Channel).
5. Access the P4: Zone/Delay- Vel Z T01-08 page.
6. Set Timbre 1's Top Velocity to 127, and its Bottom Velocity to 64.

You can also enter a velocity value by selecting the parameter and then playing a note on the keyboard while holding down the ENTER switch.

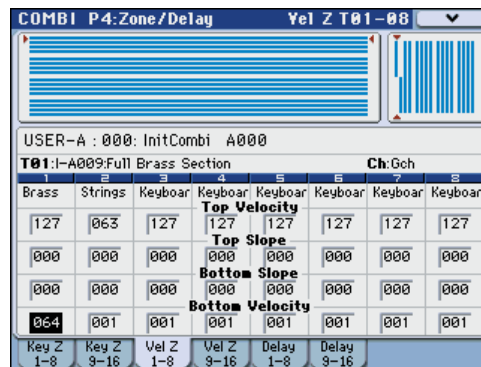

7. Set Timbre 2 to a Top Velocity of 63, and a Bottom Velocity of 1.

### Velocity Zone Slope

Similar to Key Zone Slopes, as described above, these let you fade in and fade out sounds gradually over a velocity range, instead of a simple hard switch.

In the case of the above example, you could set the velocity zones of the two Timbres so that they partially overlap. Then, set the Top Slope and Bottom Slope so that the sound changes gradually, instead of changing suddenly between velocity values of 63 and 64.

## MIDI settings

### Timbre Parameters MIDI page

#### Status

This controls the status of MIDI and the internal tone generator for each Timbre. Normally, if you're playing an internal Program, this should be set to **INT**.

If the status is set to **Off**, **EXT**, or **EX2**, that internal sounds will not be played. **Off** simply disables the Timbre entirely. The **EXT** and **EX2** settings allow the Timbre to control an external MIDI device.

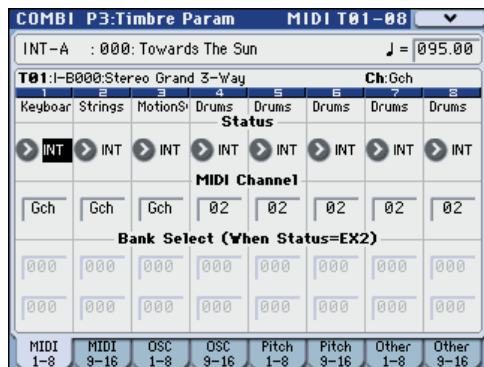

For details, please see "Status" on page 149 of the Parameter Guide.

#### Bank Select (when status=EX2)

When the **Status** is set to **EX2**, these parameters allow you to transmit MIDI Bank Select messages for changing banks on external MIDI devices.

#### MIDI Channel

Timbres that you wish to play from M3's keyboard must be set to the global MIDI channel. Your playing on the keyboard is transmitted on the global MIDI channel, and will sound any timbre that matches this channel. Normally you will set this to **Gch**. When this is set to **Gch**, the MIDI channel of the timbre will always match the global MIDI channel, even if you change the global MIDI channel.

🔍 On some preloaded Combinations, Timbres used by KARMA may have their MIDI Channels set to something other than **Gch**. These will be timbres that play only when KARMA is on—a very useful technique for creating "KARMALized" Combinations.

For details, please see "KARMA function settings in Combination mode" on page 176. In particular, note the relationships between KARMA assignments and MIDI Channel.

## MIDI filter settings

For each MIDI Filter item, you can specify whether or not the corresponding MIDI message will be transmitted and received. The **checked** items will be transmitted and received.

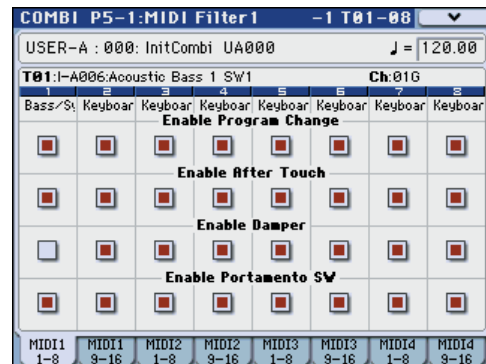

The MIDI filters don't turn the functions themselves on or off. Instead, the filter just controls whether or not that MIDI message will be transmitted and received.

For example, if portamento is on, portamento will be applied to the internal M3 sound even if Portamento SW CC#65 is unchecked.

As another example, let's say that you've selected a bass Program for Timbre 1, and a piano Program for Timbre 2, with the goal of creating a bass/piano split. You could make the following settings so that pressing the damper pedal affects only Timbre 2's piano sound:

1. Access the **P5-1: MIDI Filter1-1 T01-08** page.
2. Un-check the **Enable Damper** box for **Timbre 1**.
3. Check the **Enable Damper** box for **Timbre 2**.

## Altering Programs to fit within a Combination

You can make various changes to Programs within the context of a particular Combination, to make them fit better with other Programs, or to create particular sonic effects. These changes do not affect the original Programs, or how those Programs sound in other Combinations.

### Timbre Parameters: OSC



#### Force OSC Mode

Normally this should be set to **PRG**, so that the sound will play as set by the original Program.

If you wish to force a polyphonic program to sound monophonically, set this either to **MN** (Mono) or **LGT** (Legato). Conversely, set this to **Poly** if you wish to force a monophonic program to play polyphonically.

For details, please see “Force OSC Mode,” on page 150 of the Parameter Guide.

#### OSC Select

Normally, this should be set to **BTH** (Both).

If the timbre is using a Program whose **Oscillator Mode** is **Double**, and you want only **OSC1** or **OSC2** (not both) to sound, set this to **OSC1** (only **OSC1** will sound) or **OSC2** (only **OSC2** will sound).

#### Portamento

Normally, this should be set to **PRG**.

If the Program uses portamento, but you’d like to disable this for the current Combination, set this parameter to **Off**.

Conversely, if you want to force the portamento to be on, or just to change the portamento time, set this to a value of **001–127**. The portamento will change to use the newly specified time.

### Timbre Parameters: Pitch

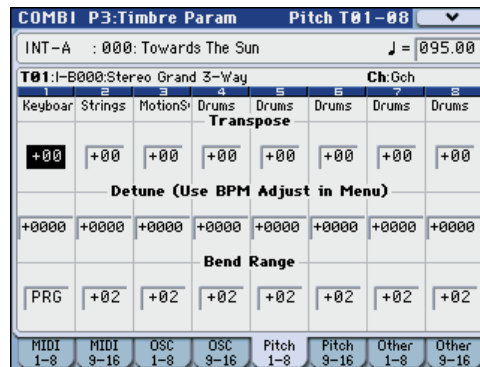

#### Transpose, Detune (BPM Adjust)

These parameters adjust the pitch of the timbre.

- In a layer-type combination, you can set two or more timbres to the same program, and create a richer sound by using **Transpose** to shift their pitch apart by an octave or by using **Detune** to create a slight difference in pitch between the two.
- In split-type combinations, you can use **Transpose** to shift the pitch (in semitone units) of the programs specified for each key zone.
- If you wish to change the playback pitch of a drum program, use **Detune**. If you change the **Transpose** setting, the relationship between notes and drum sounds will change.

#### Adjusting the BPM of multisamples or samples created in Sampling mode

If a timbre’s program uses multisamples or samples that you created in Sampling mode (or loaded in Media mode) at a specific BPM value, you can use the menu command **Detune BPM Adjust** to call up a new BPM value. This changes the BPM by adjusting the playback pitch.

For details, please see “Detune BPM Adjust,” on page 188 of the Parameter Guide.

#### Use Program’s Scale, Scale

This specifies the scale for each timbre. If you **check Use Program’s Scale**, the scale specified by the program will be used. Timbres for which this is **not checked** will use the **Scale** setting.

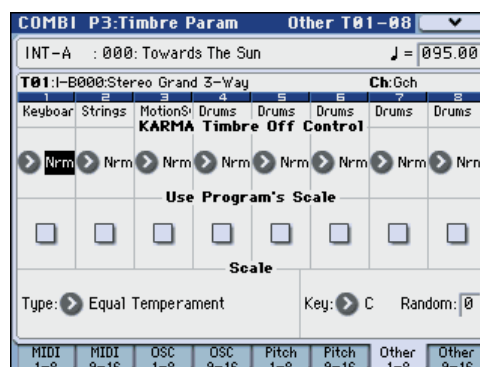

## Delay

You can set some Timbres so that they don't sound immediately at note-on. This can create cool effects, and more dramatic layers.

You can specify the delay for each Timbre either in milliseconds (ms), or in rhythmic values which sync to the system tempo.

If you set the Delay to **Key Off**, the Timbre will sound when the note is released.

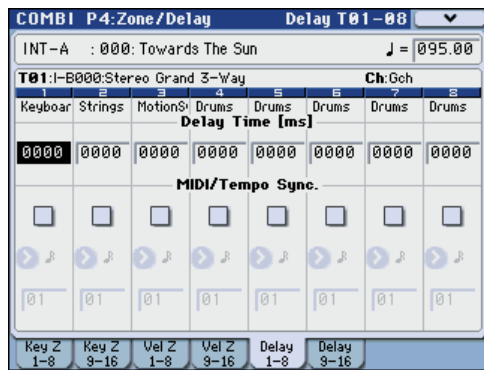

## Editing Programs with Tone Adjust

Using Tone Adjust, you can make detailed edits to Programs within the context of the Combination. These edits will not affect the original Program, or any other Combinations which use the Program. To edit a Program with Tone Adjust:

1. Press the **CONTROL ASSIGN TONE ADJUST** switch (the LED will light).
2. Access the **P0: Play- Control Surface** page.

This page mirrors the Control Surface. It's very useful with Tone Adjust, since it shows you the parameter assignments, exact values, and so on.



3. Select the Timbre whose parameters you'd like to adjust.
4. Edit the controls as desired.

In addition to editing the values, you can also change the assignments of Tone Adjust parameters to the sliders, and switches.

For details, please see "Using Tone Adjust" on page 49.

## Effects

Effects are covered in their own section of the manuals, so we won't go into too much detail here.

## Insert Effects

Insert Effects let you send either individual Oscillators or the entire Program through up to 5 effects, in series. You can use any type of effects, from distortions and compressors to choruses and reverbs. The Insert Effect output can be routed to the (MAIN) L/MONO and R jacks, as well as to each INDIVIDUAL jack.

Two double-size effects (154: St.Mltband Limiter - 170: Early Reflections) can be used in IFX1-4, plus one normal effect for a maximum of three effects. You can also use one double-size effect and up to three normal effects for a total of up to four effects.

For details, please see "Insert effects" on page 155.

## Master Effects

There are two Master Effects, which are accessed through Sends 1 and 2. These are best-suited to effects such as reverbs and delays. You can use any type of effect, but double-size effects can be used only in master effect 1. When using a double-size effect, master effect 2 cannot be used.

For details, please see "Master effects" on page 156.

## Total Effect

The Total Effect is dedicated to processing the main L/R outputs. The Total Effect is suitable for use with effect types that are applied to the entire mix, such as compressor, limiter, or EQ.

You can use effects other than double-size effects.

For details, please see "Total Effect" on page 157.

## Automatically importing a Combination into Sequencer mode

The Auto Song Setup feature automatically applies the settings of the current Combination to a song.

If inspiration for a phrase or song strikes you while you're playing a program or combination, you can use this function to start recording immediately.

Hold down the **ENTER** switch and press the **SEQUENCER REC/WRITE** switch. The **Setup to Record** dialog box will open and ask "Are you sure?". Press "OK". You will automatically enter Sequencer mode, and will be in the record-ready state. Press the **START/STOP** switch to start the sequencer and begin recording.





# Creating songs (Sequencer mode)

## Overview

### About the M3's Sequencer

The M3's sequencer is a 16-track MIDI sequencer that can hold up to 128 songs and 210,000 MIDI events.

You can record and play back MIDI data using sixteen MIDI tracks and one master track (containing tempo data, etc.) to control the internal sound generator and your external sound modules.

The M3 also provides an In-Track Sampling function that automatically creates the appropriate note data in a track if you sample an external audio source while your song plays.

You can connect a USB CD-R/RW drive (commercially available) and create an audio CD of your completed songs. (See page 127, and page 150)

With its broad range of capabilities such as its In-track Sampling function, Time Stretch/Slice function, KARMA function, high-quality effects, and controllers, the M3 is the ideal environment for music production or live performance.

⚠ When you turn off the power, the settings made in Sequencer mode and the song data, and any user pattern data that you recorded will not be backed up. If you wish to keep this data, you must save it on USB storage media before turning off the power, or perform a MIDI data dump to save the data on an external data file etc.

If you wish to save the programs, track parameters, effects, and KARMA function settings etc. selected for a song as a template song, use the menu command **Save Template Song**.

Immediately after the power is turned on, M3 will not contain any song data, so if you wish to play a song on the sequencer, you must first load data from media, or receive a MIDI data dump from a MIDI file. For details, please see "Loading data" on page 145, and "Receiving SysEx data dumps" on page 385 of the Parameter Guide.

### Sequencer mode structure

Sequencer mode is structured as follows.

#### Songs

A song consists of MIDI tracks 1–16, a master track, song parameters such as the song name, X–Y control, KARMA function, Drum Track function, effect and RPPR parameters, and 100 user patterns.

A maximum of 128 such songs can be created on M3.

MIDI tracks 1–16 each consist of setup parameters located at the start location, and musical data within the track. The master track consists of tempo and time signature data.

#### Setup parameters & Musical data

Each song consists of MIDI tracks 1–16, a master track, various song parameters such as the song name, settings for the X–Y control function, settings for the KARMA function, Drum Track function, effect settings, RPPR function parameters, and 100 user patterns.

Up to 128 such songs can be created in the M3.

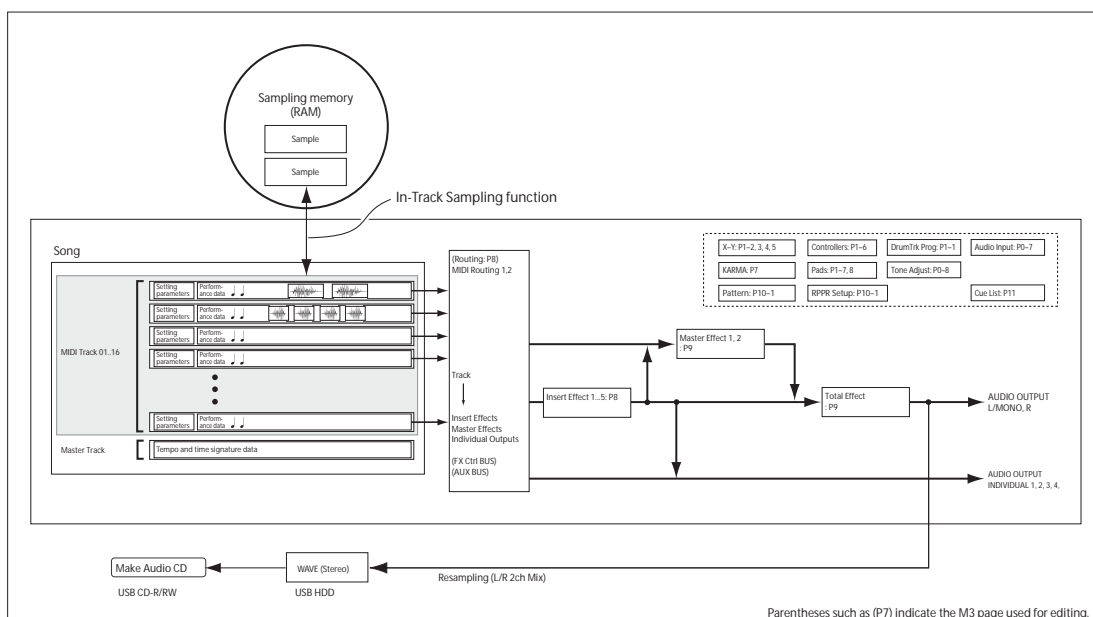

MIDI tracks 1–16 each consist of “track parameters” that specify the starting state of the track, and “playback data.” The master track consists of tempo and time signature data.

### MIDI tracks 1–16

#### Setup parameters

Bank/Program No.\*, Play/Rec/Mute, Pan\*, Volume\*  
Track Play Loop, Loop Start Measure, Loop End Measure, Play Intro, EQ (Bypass, Input Trim, Low Gain, Mid Frequency, Mid Gain, High Gain) Status, MIDI Channel, Bank Select (When Status=EX2), Force OSC Mode, OSC Select, Portamento\*, Transpose\*\*, Detune\*\*, Bend Range\*\*, Use Program’s Scale, Delay (Mode, Time, Base Note, Times), KARMA Track On/Off Control, MIDI Filter, Keyboard Zones, Velocity Zones, Track Name, IFX/Indiv.Out Bus, FX Control Bus, AUX Bus, Send1 (MFX1)\*, Send2 (MFX2)\*, Drum Kit IFX Patch, X–Y Volume, X–Y CC, Enable RADIAS

#### Musical data

Note On/Off  
Program Change (including Bank Select)  
Pitch Bend  
Aftertouch (Poly After)  
Control Change  
Pattern No.  
Exclusive Message

#### Master track

#### Setup parameters/Musical data

Time signature\*, Tempo\*

\* When you change the setting during realtime-recording, this will be recorded as musical data. This allows the starting settings to be modified during the playback.

\*\* Musical data (MIDI RPN data) can be used to change the starting settings during playback.

Other parameters: You can adjust parameters during realtime recording and record these changes as MIDI System Exclusive messages. This means that the settings at the start of playback can change as the song progresses.

For details on Control Change messages and RPN, please see “Control change” on page 616, and “Using RPN (Registered Parameter Numbers)” on page 620 of the Parameter Guide.

For details on MIDI System Exclusive messages, please see “About system exclusive messages” on page 621 of the Parameter Guide.

### Song recording and editing

Song recording is performed on tracks.

You can record MIDI tracks in either of two ways; realtime recording or step recording. For realtime recording you can choose one of six recording modes.

You can edit MIDI tracks by using Event Edit operations to modify the recorded data or insert new data, and by using Track Edit operations such as Create Control Data, which inserts pitch bend, aftertouch, or control change data.

## Patterns

There are two types of patterns: preset patterns and user patterns.

**Preset patterns:** Patterns suitable for drum tracks are preset in internal memory, and can be selected for any song.

**User patterns:** Each song can have up to 100 patterns. When using a pattern in a different song, use the Utility menu commands **Copy Pattern** or **Copy From Song** etc. to copy the pattern. The pattern length can be specified in units of a measure.

Each pattern consists of musical data for one track. It is not possible to create patterns that contain multiple tracks.

You can use these patterns by placing them in a MIDI track (**Put to Track** menu command) or by copying them (**Copy to Track** menu command). You can also use patterns with the RPPR function of a song.

### How Sequencer patterns are related to Drum Track patterns

The patterns of the Drum Track function you use with a Program or Combination are related to Sequencer mode patterns as follows.

Preset patterns are a common library that can also be used by the Drum Track function.

User patterns cannot be directly used by the Drum Track function, but they can be converted to user Drum Track patterns and used with a Program or Combination. If you convert a user pattern, it will be stored in internal memory, and this data will not disappear even when you turn off the power.

## Cue List

The cue list allows you to playback multiple songs in succession. The M3 lets you create twenty cue lists. Each cue list lets you connect up to 99 songs and specify the number of times that each song will repeat.

The menu command **Convert to Song** lets you convert the songs in a cue list into a single song.

For example you can use a cue list to create the backing, convert the cue list to a song, and then add solo phrases on unused tracks.

## Sequencer mode page structure

	Page	Main content
PLAY	P0-1: Play/REC	Song selection, playback, and recording. Program selection for each track. Pan and volume settings etc. for each track. Track playback loop settings. Audio input settings and resampling settings. Recording method selection.
	P0-2: Play/REC Control	Simple KARMA editing. Editing from the control surface.
EDIT	P1: DT/XY/Ctrls	Drum Track settings. X-Y control settings. SW1, 2, and slider function settings. Pad note and velocity settings.
	P2: EQ/Option	EQ settings for each track. Settings for the EXB-RADIUS option.
	P3: Track Param	Various parameter settings for each track (MIDI channel, OSC selection, Pitch setting, etc.)
	P4: Zone/Delay	Key split and layer settings. (Key zone and velocity zone) Time delay from note-on to beginning of sound.
	P5-1: MIDI Filter1	MIDI transmit/receive filter 1 settings.
	P5-2: MIDI Filter2	MIDI transmit/receive filter 2 settings.
	P6: Track Edit	Step recording. Event recording. Copy, delete, and other track editing.
KARMA	P7-1: KARMA1 GE Setup	Overall KARMA settings.
	P7-2: KARMA2 Module	Settings for each KARMA module.
	P7-3: KARMA3 GE RTP	KARMA GE realtime parameter settings.
	P7-4: KARMA4 Perf	KARMA performance parameter settings.
EFFECT	P8-1: IFX-Routing1	Oscillator output bus and master effect send level settings. Insert effect routing, selection, and settings.
	P8-2: IFX-Routing2	Bus settings for oscillator output. Common FX LFO 1, 2 settings.
	P9: MFX/TFX	Master effect routing, selection, and settings. Total effect selection and settings.
PATTERN&CUE	P10: Pattern/RPPR	Pattern recording and editing. RPPR settings. Converting a pattern to a Drum Track pattern.
	P11: Cue List	Cue list settings. Consecutive playback of multiple songs. Converting to a song.

For details, please see “Using effects in Combinations and Songs” on page 157.

For details on how to access each mode and page, please see “Basic operations” on page 22.

The MIDI transmit/receive settings for each track are made in **MIDI Channel** (P3: Track Param- MIDI T01-08/T09-16 page).

Sampling or resampling can be performed in Sequencer mode. For details, please see “Sampling in Program, Combination, and Sequencer modes” on page 122.

Since you can apply the M3’s internal effects to the external audio inputs, a wide range of possibilities are available.

# Playing Songs

## Playback

In order to play back song data in the sequencer, you must first record song data, or load or dump it into the M3.

Let's start by loading and playing the demo song data. For details, please see "Listening to the demo songs" on page 5.

**1. Press the MODE SEQ switch to enter Sequencer mode.**

The P0-1: Play/REC- Program T01-08 or T09-16 page will appear. If this is not displayed, press the EXIT switch three times.

**2. Use "Song Select" to select the song you want to play back.**

You can press the Song Select popup button and choose from a list.

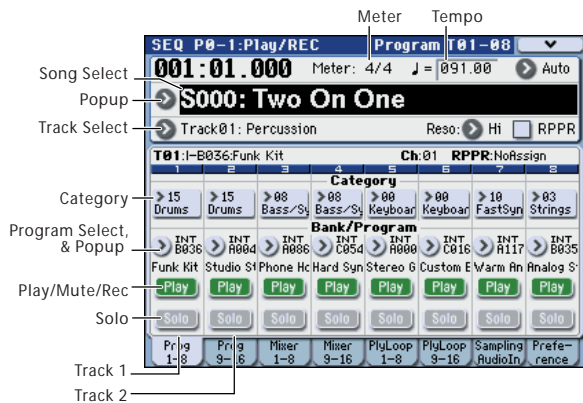

**3. Press the SEQUENCER START/STOP switch.**

The song you selected in step 2 will begin playing. The song will begin playing if you press the SEQUENCER START/STOP switch in a page other than P10: Pattern/RPPR. If you press this switch while you're in P10: Pattern/RPPR, the currently-selected pattern will begin playing. (In P11: Cue List, the songs of the cue list will be played.)

**4. During playback, you can press the SEQUENCER START/STOP switch to stop playback.**

If you press the START/STOP switch once again, playback will resume from where you stopped.

- Press the LOCATE switch to move to the assigned location.
- Press the PAUSE switch to pause playback. Press the PAUSE switch once again to resume playback.
- Press the <<REW or FF>> switches to rewind or fast-forward. You can use this during playback or while stopped. You can use the FF/REW SPEED menu command to specify the rewind and fast-forward speeds.
- To set the tempo, turn the TEMPO knob or press the TAP TEMPO switch at the desired interval.

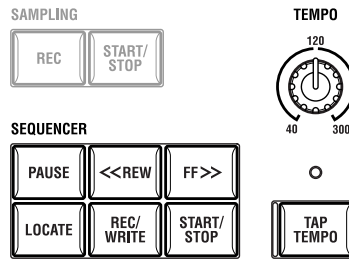

## Muting just a specific track/ Monitoring just a specific track (Mute/ Solo functions)

The M3 provides a Mute function that lets you silence specified MIDI tracks 1-16 or audio input channels (1, 2, S/P DIF L, R), and a Solo function that lets you hear the specified track or channel by itself. These functions can be used in various ways. For example you can intentionally mute or solo specific tracks, or listen only to the rhythm section of the previously-recorded tracks while you record new tracks. Let's try out the Mute and Solo functions.

*Tip:* You can also control Play/Rec/Mute and Solo On/Off from the Control Surface. For details, please see "Adjusting the Volume, Mute, and Solo of each track" on page 82.

**1. Use "Song Select" to select the song that you want to play back.**

**2. Press the SEQUENCER START/STOP switch.**

**3. Press track 1 Play/Rec/Mute.**

The display will change from Play to Mute, and the playback of track 1 will no longer be heard. In this way, the "mute" function allows you to silence a specified track until the track is un-muted.

Press track 2 Play/Rec/Mute. The display will change, and the playback of track 2 will also be muted. To cancel muting, press Play/Rec/Mute once again.



**4. Press track 1 "Solo On/Off."**

"Solo" will be highlighted, and this time, only the performance of track 1 will be heard. To play back only a specified track by itself in this way is known as "soling" the track (turning Solo on).

If both Mute and Solo are used, the Solo function will be given priority.

Press track 2 "Solo On/Off."

The display will change, and you will hear the playback of tracks 1 and 2.

Solo On applies to all MIDI tracks 1-16 and audio input channels (1, 2, S/P DIF L, R).

If as in this example, you've turned Solo on for only MIDI tracks 1 and 2, you will not hear MIDI tracks 3-16, or the audio input channels (1, 2, S/P DIF L, R).





5. To switch Solo off, press Solo On/Off once again. Press Solo On/Off for both MIDI tracks 1 and 2.

The display will change, and the playback of tracks 1 and 2 will be muted. If the Solo function is turned off for all tracks, playback will be according to the **Play/Rec/Mute** settings.

### Exclusive Solo

Normally, the Solo function operates in “Exclusive Solo off” mode, where you can solo more than one track at a time (as in the example above). In contrast, “Exclusive Solo on” mode allows only one track/channel to be soloed at a time, making it easy to switch between soloed tracks.

Use the **Exclusive Solo** menu command to specify how the Solo function will operate.

**Exclusive Solo off:** You will be able to solo more than one track at a time. The status of a track will change each time you press its Solo On/Off button.

**Exclusive Solo on:** When you press a Solo On/Off button, only that track will be soloed.

 The **SOLO** setting is not stored when you save the song.

*Tip:* You can turn Exclusive Solo on/off by holding down the ENTER switch and pressing numeric key 2.

### LOCATE settings

You can press the LOCATE switch to move to the registered location. Initially, this will move to 001:01.000.

To change the registered location, use the **Set Location** menu command. Alternatively, you can register a location during playback by holding down the ENTER switch and pressing the LOCATE switch.

When you select a song, the **LOCATE** setting is automatically initialized to 001:01.000.

For details, please see “Set Location (Set Location for Locate Key)” on page 272 of the Parameter Guide.

### Loop playback

When recording or playing back a song, you can individually loop the MIDI tracks that are playing.

In the P0-1: Play/REC- Play Loop T01-08 or T09-16 page, check **Track Play Loop** for the MIDI tracks you want to loop, and use **Loop Start Measure** and **Loop End Measure** to specify the starting and ending measure of the region that will play back as a loop.

If you check **Play Intro**, the measures preceding the loop will be played back as an introduction before the loop begins.



If you play back from the first measure with the settings shown in the screenshot above, the specified region of measures will repeat as follows.

Measures	1	2	3	4	5	6	7	8	9	10	11	12	13
Track 1	1	2	3	4	5	6	7	8	5	6	7	8	5
Track 2	9	10	9	10	9	10	9	10	9	10	9	10	9

If **Play Intro** is unchecked, the specified region of measures will repeat as follows.

Measures	1	2	3	4	5	6	7	8	9	10	11	12	13
Track 1	5	6	7	8	5	6	7	8	5	6	7	8	5
Track 2	9	10	9	10	9	10	9	10	9	10	9	10	9

### Global mode “SEQ Mode” setting

In SEQ mode you will normally use the internal sequencer as the master that controls the internal sound generator and your external sound modules. However, you can also use SEQ Mode as a multi-timbral sound module that simultaneously plays multiple tracks of performance data from your external MIDI sequencer. (Normally you’ll use Combination mode if you want to use the M3 as a master keyboard.)

So that you can change settings as appropriate for these two uses, the M3 provides a SEQ Mode **Track MIDI Out** parameter which is located in the Global P1: MIDI- MIDI Basic page.

Master is the setting to choose if you’re using the M3’s internal sequencer to control an external sound module, or if you’re using the M3 in Sequencer mode as a master keyboard. In this case when you switch songs on the M3, tracks whose **Status** is set to EXT or BTH will transmit program changes and other MIDI messages to set up your external MIDI sound module.

External-Sequencer is the setting to choose if you’re using the M3 as a multi-timbral sound module controlled by an external sequencer. When you switch songs on the M3, program changes and other MIDI messages will not be transmitted (from tracks whose **Status** is set to EXT or BTH). This means that echo-back from your external MIDI sequencer will not change the program, pan, or volume settings of M3 tracks that are receiving the same MIDI channels.

## Control using the sliders and switches

You can use the control surface to perform a variety of control. You can perform this control in realtime during playback or recording.

For example, you can adjust the volume of each track, or change the cutoff or resonance. You can also turn effects on/off or adjust their depth, or modify the phrases generated by KARMA.

Here we will explain how to control the volume, mute, and solo settings of each track. For other types of editing, refer to the explanations below.

Realtime control in Sequencer mode will affect the track selected by **Track Select**.



Tone Adjust will affect the track selected by **Track**.

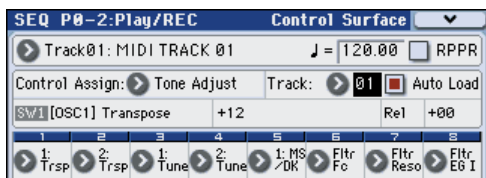

- “Using realtime control to edit sounds or effects” on page 48
- “Editing Programs with Tone Adjust” on page 75

## Adjusting the Volume, Mute, and Solo of each track

You can also edit the mixer parameters directly from the Control Surface, eight Tracks at a time.

1. Press the **MIXER** switch under **CONTROL ASSIGN**, so that the **T1-8 LED lights up**.

The switch has two LEDs: one for T1-8, T9-16 and INPUT. These correspond to Tracks 1-8, Tracks 9-16, and the audio inputs.

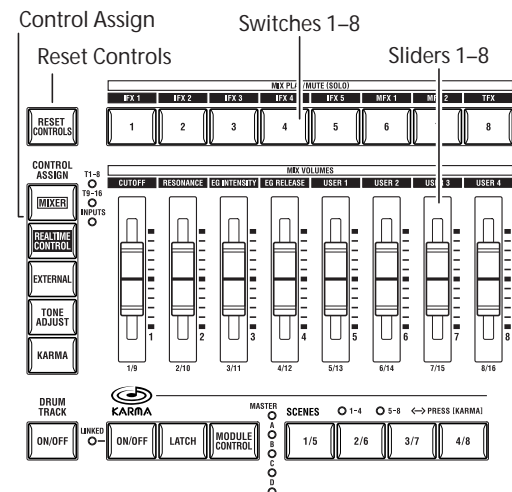

2. Access the **Seq P0-2: Play/REC- Control Surface** page.

This page displays and reflects the control surface data. It's a convenient place to adjust the sound, since you can view the actual parameter assignments and the exact data values.

*Note:* You can use the Control Surface for control regardless of the page that is shown in the display.

3. Use **sliders 1-8 to adjust the volumes of Tracks 1-8, respectively**.

4. While the display shows **Track Play/Mute**, **switches 1-8 will change the Play/Mute status of tracks 1-8**.

5. Press the **menu button** to select “**Panel-SW Solo Mode**.”

The menu will close, and the indication of Track Play/Mute in the display will change to Track Solo.

Alternatively, you can hold down the **ENTER** switch and press numeric key 1 to switch between Track Play/Mute and Track Solo.

6. While the display shows **Track Solo**, **switches 1-8 will turn Solo on/off for tracks 1-8**.

# MIDI recording

## Preparations for recording

-  Before you begin recording, make sure that the memory protect setting in Global mode is turned off. For details, please see “Memory protect” on page 142.

## Creating a Song

Before we can begin this example, we need to select an empty song where we can record.

1. Press the **MODE SEQ** switch to enter **Sequencer mode**.
2. Choose “**Song Select**” (e.g., in the **P0-1: Play/REC-Program T01-08** page).

You can press the Song Select popup button, and choose from a list.

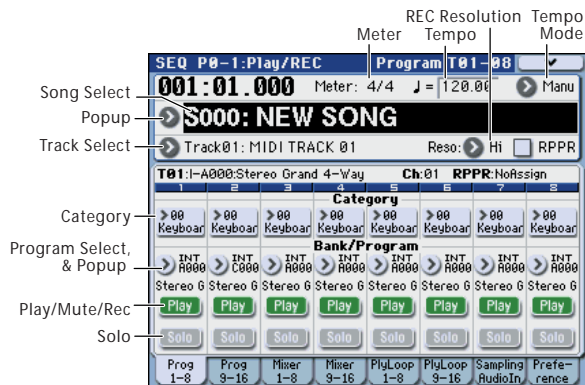

3. Use the numeric keys to input the number of the new song you want to create, and press the **ENTER** switch. (For example, press the 1 switch and then the **ENTER** switch.) A dialog box will appear.

If you pressed the Song Select popup to access the Song No. dialog box, press the desired song number to open the dialog box.



4. Use “**Set Length**” to input the desired number of measures and press the **OK** button.

You can change the number of measures later if desired. For details, please see “Set Song Length” on page 281 of the Parameter Guide.

5. Press the **OK** button to create the song.

*Tip:* You can use the **ENTER** switch instead of the **OK** button.

## Track settings

Since we’re going to record a new song in this example, we will start by explaining how to assign a program to each MIDI track, and make basic settings such as volume.

1. **Assign a program to each MIDI track.**

Use “**Program Select**” to assign a program to each MIDI track.

At this time you can press the **Category** popup and select programs by category.

You can copy various settings from Programs or Combinations, including effects, KARMA settings, Tone Adjust, and so on. (See page 64, and page 74)

2. **When assigning a program, you can use Track Select to select the track for which you are making assignments, and try playing the sound.**

3. **Set the pan and volume of each MIDI track.**

Press the **Mixer 1-8** tab (or the **Mixer 9-16** tab) to access the **Mixer T01-08** page (**Mixer T09-16** page).

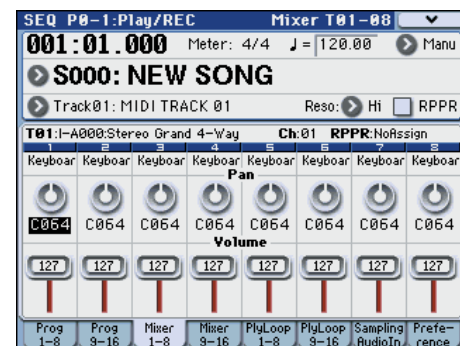

- **Pan** sets the pan of each track, and **Volume** sets the volume of each track.

4. **Specify the tone generator and MIDI channel that will be played by each MIDI track.**

Press the **PAGE SELECT** switch to access **Seq Page Select**, and press “**P3 Track Param.**” The **P3: Track Param** page will appear. Press the **MIDI 1-8** tab (or the **MIDI 9-16** tab) to access the **MIDI T01-08** page (**MIDI T09-16** page).

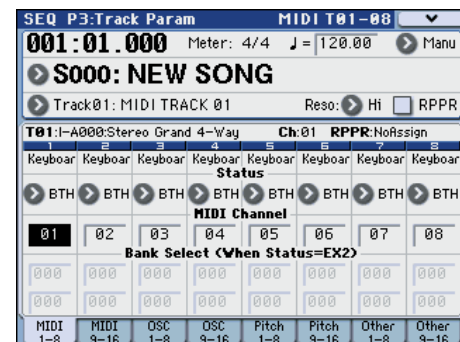

- Use **Status** to specify whether each track will play the internal and/or external sound generator.

Normally when using the M3 as a 16-timbre sound module, you will select **INT** or **BTH**.

**INT:** During playback, the M3's internal tone generator will play the MIDI data recorded on that track. When you operate the M3's keyboard or controllers, you will be playing and controlling the track selected by **Track Select**. MIDI data will not be transmitted to an external device.

**EXT, EX2, BTH:** During playback, the MIDI data recorded on that track will be transmitted from MIDI OUT to play an external sound module. When you operate the M3's keyboard or controllers, MIDI data will be transmitted to play and control the external sound module selected by **Track Select**. (The MIDI channel of the external tone generator must be set to match the **MIDI Channel** of M3 tracks that are set to EXT, EX2 or BTH.)

If **Status** is set to BTH, both the external tone generator and internal tone generator will be sounded and controlled.

- Use **MIDI Channel** to specify the MIDI channel for each track.  
Normally you will set **MIDI Channel** to a different channel 1–16 for each track. Tracks that are set to the same MIDI channel will sound simultaneously when you record or play back either of the tracks.

#### 5. Adjust the effect settings.

Make settings for each effect in P8: IFX and P9: MFX/TFX.

For details, please see “Using effects in Combinations and Songs” on page 157.

#### 6. Set the tempo and time signature.

- To set the tempo, you can turn the TEMPO knob or press the TAP TEMPO switch at the desired interval. Alternatively, you can select **♩ (Tempo)** in the P0-1: Play/REC– Program T01–08 page (or similar page), and use the VALUE controllers to set the tempo. Set **Tempo Mode** to Manual.
- Next you will set the time signature. In this example, we'll explain how to set the time signature using the “Meter” field. Normally, you specify the time signature before recording the first track, and then begin recording.
  - a) Press the SEQUENCER REC/WRITE switch, and set “Meter” to \*\*/\*\*.
  - b) Press \*\*/\*\* to highlight it, and use the VALUE controllers to set the time signature.
  - c) Press the SEQUENCER START/STOP switch to begin recording. When the pre-count has ended and Locate reaches 0001:01:000, press the SEQUENCER START/STOP switch to stop recording. The time signature you specified has been recorded on the Master track.  
If you press the SEQUENCER START/STOP switch during the pre-count, the time signature won't be recorded.

#### 7. Set the “REC Resolution” if necessary.

When you realtime-record on a MIDI track, this parameter specifies how the timing of the recorded MIDI data will be corrected. The timing will also be corrected when you realtime-record automation data on an audio track. (Already-recorded data will not be corrected.)

For example, let's suppose that you realtime-recorded some eighth notes but your timing was not quite

perfect, as shown in part 1 of the illustration below. If **REC Resolution** were set to ♩ when you recorded, the timing would automatically be corrected as shown in part 2 of the illustration. If **REC Resolution** is set to Hi, the notes will be recorded with the timing at which you play them.



#### 8. Make other settings as necessary.

Make settings for the KARMA function (P7: KARMA), MIDI filtering (P5: MIDI Filter/Zone), etc. (See “KARMA function settings in Sequencer mode” on page 180)

You may also wish to use Tone Adjust to adjust the sound. (See page 82)

When you are finished making these settings, the basic setup is complete.

#### Saving your song parameter settings

The song parameter settings you make here can be saved as a template. If you use these settings frequently, you can simply load one of the templates you've saved. For details, please see “Save Template Song (Save as User Template Song)” on page 272 of the Parameter Guide.

#### Using template songs

Loading a template song is an easy way to make settings appropriate for a particular musical style. You can also assign a drum pattern to a track at the same time.

##### 1. In the P0-1: Play/REC page, press the menu button and choose “Load Template Song.”

A dialog box will appear.



##### 2. In the “From” field, choose the template song you want to load.

##### 3. If you check “Copy Pattern to Track too?”, a dialog box for copying a pattern will automatically appear after you execute “Load Template Song.”

If you execute without checking this, only the template song you selected in step 2 will be loaded.

##### 4. Press the OK button to load the template song, or press the Cancel button if you decide to cancel.

When you execute this operation, song settings other than MIDI Track Loop and RPPR will be copied.

If you executed this operation with **Copy Pattern to Track too?** checked in step 3, the **Copy Pattern To Track** dialog box will appear.

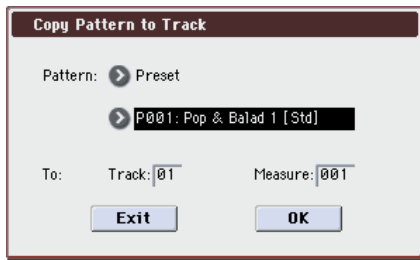

This dialog box is the same as the one that appears for the **Copy To Track** (P10: Pattern/RPPR– Pattern Edit) menu command.

**5. In the “Pattern” field, select the pattern that you want to copy.**

You can press the SEQUENCER START/STOP switch to play back the selected pattern.

In the **To Track** field, select the copy-destination track.

In the **Measure** field, specify the starting measure of the copy-destination.

Following the pattern name for each of the 522 preset patterns, the musical style and the name of the most suitable Drums category program are partially displayed.

By loading a drums track and the corresponding preset pattern, you can instantly set up a drum track appropriate for each preset template song.

**6. To execute, press the OK button.**

When you execute this operation, **Measure** will count up automatically, showing how many measures of the selected pattern have been placed in the selected song. You can then copy another pattern if desired, or add more measures of the same pattern. When you’re finished, press the Exit button.

## Recording MIDI in real-time

When you’ve finished with “Preparations for recording,” you can start recording.

This is a method of recording in which your playing on the keyboard and your operations of controllers such as the joystick are recorded in realtime. This method of recording is normally used one track at a time, and is called single track recording.

As an alternative, multitrack recording allows you to simultaneously record multiple channels of data onto multiple tracks. This is the method you will use when using the Drum Track function, the RPPR function, and the KARMA function to record multiple tracks of musical data at once, or when you playback existing sequence data on an external sequencer and record it onto M3’s sequencer in realtime.

### Recording setup

In P0–1: Play/REC– Preference page **Recording Setup**, select the realtime recording method you want to use.



### Overwrite

With this method, the musical data previously recorded on a track is overwritten by the newly recorded data. When you perform overwrite recording on a previously-recorded track, its musical data will be deleted and replaced by the newly recorded data.

Normally you will use this method to record, and then modify the results by using other types of realtime recording or MIDI event editing.

1. Use **Track Select** to select the track that you want to record.
2. Set the **Recording Setup** to **Overwrite**.

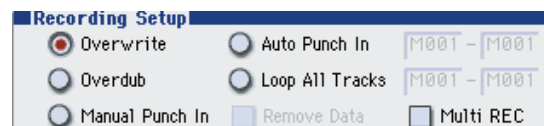

3. In “**Location**,” specify the location at which you wish to begin recording.
4. Press the **SEQUENCER REC/WRITE** switch, and then press the **SEQUENCER START/STOP** switch.

If the **Metronome Setup** is still set to the default settings, the metronome will sound for a two-measure pre-count, and then recording will begin. Play the keyboard and move controllers such as the joystick to record your performance.



**5. When you finish playing, press the SEQUENCER START/STOP switch.**

Recording will end, and the location will return to the point at which you begin recording.

If you press the PAUSE switch instead of the SEQUENCER START/STOP switch, recording will pause. When you press the PAUSE switch once again, recording will resume. When you are finished, press the SEQUENCER START/STOP switch to stop recording.

**Overdub**

With this method, the newly recorded musical data is added to the existing data.

When you perform overdub recording on a previously-recorded track, the newly recorded data will be added to the previously-recorded data.

It is best to select this mode if you will be recording additional control data, recording a drum pattern, or recording the tempo in the master track. With this mode, data can be added without erasing the existing performance data.

1. Use Track Select to select the track that you want to record.
2. Set the Recording Setup to Overdub.

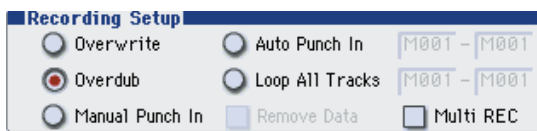

3. For the rest of the procedure, please see steps 3-5 of "Overwrite."

**Manual punch-in**

While the song is playing, you can press the SEQUENCER REC/WRITE switch or a connected pedal switch at the desired location to start or stop recording. With this method, the musical data previously on the track is overwritten by the newly recorded data.

1. Use Track Select to select the track that you want to record.
2. Set the Recording Setup to Manual Punch In.

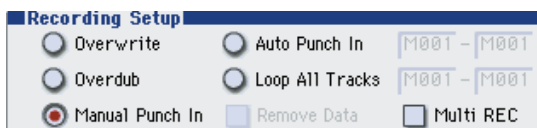

3. In "Location," specify a location several measures earlier than the point at which you wish to begin recording.
4. Press the SEQUENCER START/STOP switch.

Playback will begin.

5. At the point at which you wish to begin recording, press the SEQUENCER REC/WRITE switch.

Recording will begin. Play the keyboard and operate controllers such as the joystick to record your performance.

6. When you finish recording, press the SEQUENCER REC/WRITE switch.

Recording will end (playback will continue).

*Note:* Instead of pressing the SEQUENCER REC/WRITE switch in steps 5 and 6, you can use a foot switch connected to the ASSIGNABLE SWITCH jack.

Set the Global P2: Controllers page **Foot Switch Assign** to Song Punch In/Out. (See "Specifying the function of the Assignable Switch and Assignable Pedal" on page 132)

7. Press the SEQUENCER START/STOP switch.

Playback will stop, and you will return to the location that you specified in step 3.

**Auto punch-in**

First you must specify the area that will be re-recorded. Then recording will occur automatically at the specified area. With this method, the musical data previously on the track is overwritten by the newly recorded data.

1. Use Track Select to select the track that you want to record.
2. Set the Recording Setup to Auto Punch In.

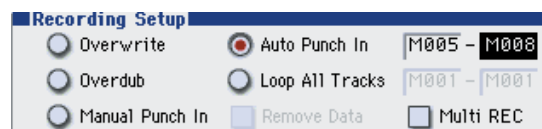

3. In "M (Auto Punch In Start Measure), "M (Auto Punch In End Measure)" specify the area that you wish to record.

For example if you specify M005-M008, recording will occur only from measure 5 to measure 8.

4. In "Location," specify a location several measures earlier than the point at which you wish to begin recording.
5. Press the SEQUENCER REC/WRITE switch, and then press the SEQUENCER START/STOP switch.

Playback will begin.

When you reach the starting location you specified in step 3, recording will begin. Play the keyboard and operate controllers such as the joystick to record your performance. When you reach the ending location you specified in step 3, recording will end. (Playback will continue.)

6. Press the SEQUENCER START/STOP switch.

Playback will stop, and you will return to the location you specified in step 4.

**Loop All Tracks**

This method lets you continue recording as you add musical data.

The specified region can be recorded repeatedly. This is ideal when recording drum phrases, etc.

Use Track Select to select the track that you want to record.

1. Set the Recording Setup to Loop All Tracks.
2. If Multi REC is checked, it will not be possible to select Loop All Tracks.

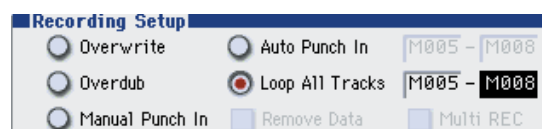

3. In “M (Loop Start Measure), “M (Loop End Measure)” specify the area that you wish to record.

For example if you specify M004–M008, recording will occur repeatedly (as a loop) from measure 4 to measure 8.

4. In “Location,” specify a location several measures earlier than the point at which you wish to begin recording.
5. Press the SEQUENCER REC/WRITE switch, and then press the SEQUENCER START/STOP switch.

Playback will begin. When you reach the starting location you specified in step 3, recording will begin. Play the keyboard and operate controllers such as the joystick to record your performance.

When you reach the ending location you specified in step 3, you will return to the starting location, and continue recording.

6. The musical data that is loop-recorded will be added to the previously-recorded data.

You can also erase specific data even while you continue loop recording.

If you press the SEQUENCER REC/WRITE switch during loop recording, all musical will be removed from the currently selected track as long as you continue pressing the switch.

By checking the **Remove Data** check box you can erase only the specified data. During loop recording, press the note that you wish to delete, and only the data of that note number will be deleted from the keyboard as long as you continue pressing that note.

Similarly, bender data will be deleted as long as you tilt the joystick in the X (horizontal) direction, and aftertouch data will be deleted as long as you apply pressure to the keyboard.

When you are once again ready to record musical data, uncheck the **Remove Data** check box.

7. Press the SEQUENCER START/STOP switch.

Playback will end, and you will return to the recording start location that you specified in step 4.

If Loop All Tracks is selected, normal playback will be looped as well.

## Multi (multitrack recording)

Multitrack recording allows you to simultaneously record onto multiple tracks, each with a different channel.

1. Make the desired Recording Setup settings.

You can record using Overwrite, Overdub, Manual Punch In, or Auto Punch In.

2. In “Recording Setup,” check “Multi REC.”

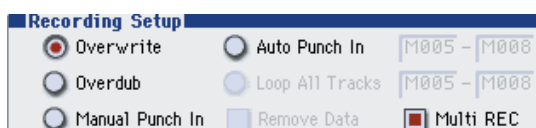

3. Use “Location” to specify the measure at which recording will begin.
4. Press the SEQUENCER REC/WRITE switch.
5. For the track you want to record, press Play/Rec/Mute to make it indicate Rec.

6. Press the SEQUENCER START/STOP switch.

With the default settings for **Metronome Setup**, the metronome will sound for a two-measure pre-count, and then recording will begin. Now you can perform on the keyboard and controllers, and use the KARMA or RPPR functions if desired.

7. Press the SEQUENCER START/STOP switch.

Playback will stop, and you will return to the location specified in step 3.

## An example of realtime recording

In this example, we’ll assign a drum program to MIDI Track 01 and create the following one-measure drum phrase.

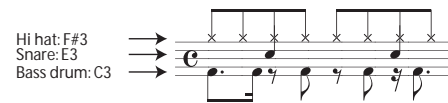

1. Create a new song, and specify a drum program for MIDI Track 01.

Use **Track Select** to select MIDI Track 01, and verify that you hear a drum program. (See page 83)

2. Access the P0-1: Play/REC- Preference page. In **Recording Setup**, specify “Loop All Tracks” and set it to M001-M001.

For details, please see “Loop All Tracks” on page 86.

With this setting, measure 1 will be recorded repeatedly. The newly recorded data will be added at each pass.

3. Set “REC Resolution” to ♩. (See page 84)
4. Press the SEQUENCE REC/WRITE switch, and then the START/STOP switch.

The metronome will sound a two-measure count-down, and then recording will begin.

5. As shown in the musical example printed above, start by playing the C3 note of the keyboard to record the bass drum for one measure.
6. Next, play the E3 note of the keyboard to record the snare for one measure, and then the F#3 note to record the hi-hat.
7. Press the SEQUENCER START/STOP switch to stop recording.
8. Play back the result, and listen to the drum performance you recorded.

Press the SEQUENCER START/STOP switch. When you’ve finished listening, press the START/STOP switch once again to stop playback.

9. If you’re not satisfied with the result, press the COMPARE switch to return to the state prior to recording, and then re-record from step 4.

*Note:* When you’re finished recording, change the Recording Setup back to the normally-used **Overwrite** (P0-1: Play/REC- Preference page).

In addition, access the P0-1: Play/REC- Play Loop T01-08 page, check **Track Play Loop** for MIDI Track 01, and set the **Loop Start Measure** and **Loop End Measure** to 001. When you play back, MIDI track 01 will repeatedly play the first measure.

## Step recording

Step recording is the recording method in which you specify the duration and strength of each note, and use the keyboard to specify the pitch of each MIDI note.

You can use the Rest button and Tie button of the dialog box to input rests and ties.

Step recording is useful when you want to create mechanically precise beats, or when you need to record a phrase that would be difficult to play by hand “in realtime,” or when you find it difficult to play extremely complicated or rapid passages.

### An example of step recording

In this example, we’ll assign a bass program to MIDI Track 02 and step-record the following two-measure bass phrase.



1. Specify a bass program for MIDI Track 02. Use Track Select to select MIDI Track 02, and verify that you hear a bass program.
2. Access the P6: Track Edit– Track Edit page.
3. Set “From Measure” to 001.

With this setting, step recording will begin from measure 1.

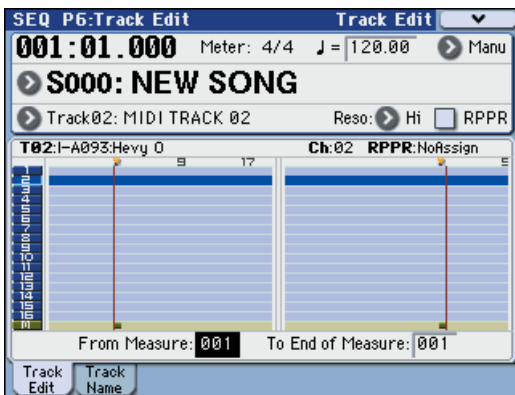

4. Press the menu button, and press menu command “MIDI Step Recording.”

A dialog box will appear.

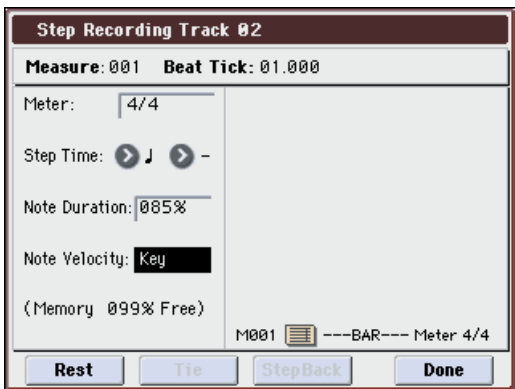

5. In “Step Time,” use “Select” to specify the basic timing value at which you will input notes and rests.

Input the first C3 note as ♩. (dotted eighth note).

Use the popup button at the left to select ♩.

You can choose from the range ♩ (whole note)– ♩ (32nd note).

Input a dotted note by selecting “.” with the popup buttons at right.

You can specify “3” to input a triplet. If you want to use the unmodified length of the note that’s selected at the left, choose “-”.

“Note Duration” indicates the length that the note itself will sound. Smaller values will produce a staccato note, and larger values will produce a legato note. For this example, leave this setting unchanged.

“Note Velocity” is the velocity (playing strength), and larger values will produce a louder volume. Set this to Key.

If you select Key for this parameter, the velocity with which you actually play the keyboard will be input.

6. On the keyboard, press and then release the first C3 note that you want to input.

The data you input will appear in the display as numerical values. In the upper right, Measure 001 Beat Tick 01.000 will change to Measure 001 Beat Tick 01.360. The next note you input will be placed at this location.

7. Input the remaining notes as described in steps 5 and 6. (You’ve already input the first C3 note.)

In addition to the methods described in steps 5 and 6, you can also use the following input methods.

- To input a rest, press the Rest button. This will input a rest of the Step Time value.
- To modify the length of a note, you can modify the Step Time value before you input the note. However if you want to extend the length (tie) of the note, press the Tie button. At this time, the previously-input note will be extended by the Step Time length.
- To delete a note or rest that you input, press the Step Back button. The previously-input note will be deleted.
- To input a chord, simultaneously press the notes of the desired chord. Even if you do not press them simultaneously, notes that are pressed before you fully remove your hand from all keys on the keyboard will be input at the same location.
- If you want to verify the pitch of the note that you will input next, press the PAUSE switch. In this state, playing a key will produce a sound, but will not input a note. Press the PAUSE switch once again to cancel the record-pause state, and resume inputting notes.

Note	Step Time: Select	Step Time: . 3 -	Key, Button	Measure/ Beat Tick
C3		.	C3 key	001 / 01.000
G3		-	G3 key	001 / 01.360
7		-	Rest button	001 / 02.000
C4		-	C4 key	001 / 02.240
7		-	Rest button	001 / 02.360
C4		-	C4 key	001 / 03.120
D3		-	D3 key	001 / 03.240
Eb3		-	Eb3 key	001 / 04.000
E3		-	E3 key	001 / 04.240
F3		-	F3 key	002 / 01.000
7		-	Rest button	002 / 01.120
C3		-	C3 key	002 / 01.360
7		-	Rest button	002 / 02.000
F2		-	F2 key	002 / 02.240
Tie		-	Tie button	002 / 03.000
F2		-	F2 key	002 / 03.240
7		-	Rest button	002 / 03.360
A2		-	A2 key	002 / 04.000
A3		-	A3 key	002 / 04.240
7		-	Rest button	002 / 04.360

### 8. When you are finished recording, press the Done button.

Press the SEQUENCER START/STOP switch to play back.

Access the P0: Play/REC– Play Loop T01–08 page, check **Track Play Loop** for MIDI Track 02, set **Loop Start Measure** to 001, and **Loop End Measure** to 002. MIDI track 02 will play measures 1–2 repeatedly.

### 9. If you're not satisfied with the result, press the COMPARE switch to return to the state prior to recording, and then re-record from step 4.

When you begin step recording, all data in the MIDI track that follows the measure where you began recording will be erased. You need to be aware of this if you begin step recording from a measure mid-way through the song.

If you want to copy data into a measure that already contains data, perform step recording in an empty MIDI track, and use the **Move Measure** or **Copy Measure** menu commands. For details, please see “Copy Measure” on page 284 of the Parameter Guide, and “Move Measure” on page 284 of the Parameter Guide.

If you want to edit or add to the recorded data, you can use the **Event Edit** function. For details, please see “Event Edit” on page 280 of the Parameter Guide.

## Recording variation

### Recording the sound of a Combination or Program

Here's how you can easily copy the settings of a Combination or Program, and then record using that sound.

When you're performing in Program or Combination mode, you can use the Auto Song Setup function to automatically set up the settings of that program or combination into a song. Alternatively, you can use the Sequencer mode menu commands **Copy From Combi** and **Copy from Program** to set up a song in a similar way.

### Auto Song Setup function

The explanation of the Auto Song Setup function given here follows the procedure from Combination mode.

1. Enter Combination mode.
2. If you change any of the settings in the combination in the Combi P0: Play– Program T01–08 page.

Such as panning, volume and KARMA setting you must first save the edited settings using **Update Combination** or **Write Combination**.

3. Hold down the ENTER switch and press the SEQUENCER REC/WRITE switch.

The Setup to Record dialog box will appear.

4. Press the OK button to perform the Auto Song Setup.

The M3 will automatically switch to Sequencer mode, and the combination's settings will be applied to a new song. The new song will be the first unused song.

5. You will automatically enter record-ready mode, and the metronome will begin sounding according to the settings in P0–1: Play/REC– Preference page.
6. Press the SEQUENCER START/STOP switch, and realtime recording will begin.

When you're finished recording, press the START/STOP switch once again.

### Settings that are automatically copied from the combination

The settings that will be automatically copied will be the same settings as if you had executed the menu command **Copy From Combi**, and had made the following settings in the dialog box.

- IFXs, MFXs and TFX checked
- Multi REC Standby checked

### Settings that are automatically copied from the program

The settings that will be automatically copied will be the same settings as if you had executed the menu command **Copy From Program**, and had made the following settings in the dialog box.

- IFXs, MFXs and TFX checked
- KARMA checked



- “To” set to MIDI Track 01
- “KARMA Module” set to A
- “with Drum Track” set to Track 10
- **RADIUS Vocoder** checked

For details, please see “Copy from Program” on page 273 of the Parameter Guide.

### Setup in Sequencer mode (Copy From Combination/Copy From Program)

In Sequencer mode, you can use the **Copy From Combi** and **Copy From Program** menu commands to set up a sequencer song based on a combination or program. In this example, we’ll explain how to set up a song based on a combination.

*Note:* Make sure that the global MIDI channel (Global P1: MIDI- MIDI Basic page, **MIDI Channel**) is set to 01.

#### 1. Create a new song.

For details, please see “Creating a Song” on page 83.

#### 2. Select the menu command “Copy From Combi.”

A dialog box will appear.

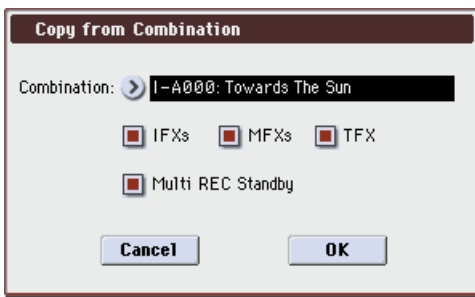

Select the program or combination that you want to copy (i.e., the copy source).

We will copy the effect settings of the combination as well, so check the **IFXs**, **MFXs** and **TFX** check boxes.

Check **Multi REC Standby**. The **Status** will be automatically set to REC for the MIDI tracks needed to record that combination.

Press the OK button to execute the copy.

Notice that when you execute this command, the **Play/Rec/Mute** setting of each track will be set automatically. The **Multi REC** check box will be checked.

#### 3. Begin recording.

Press the LOCATE switch to set the location to 001:01.000.

Press the SEQUENCER REC/WRITE switch, and then press the SEQUENCER START/STOP switch.

*Note:* If you play the keyboard during the pre-count before recording, the phrase generated by the Drum Track function, and KARMA function will start playing the moment recording begins. Record your performance.

#### 4. When you are finished performing, press the SEQUENCER START/STOP switch.

If you made a mistake or want to re-record, you can use the Compare function (press the COMPARE switch) to re-record as many times as you want. (The

**Multi REC** check box will be unchecked when you use Compare, so you will need to check it again.)

### Using the Drum Track function and the KARMA function to record on multiple MIDI tracks simultaneously

You can use multi-recording to simultaneously record a multi-track performance using the Drum Track function and KARMA function. For details, please see “KARMA function settings in Sequencer mode” on page 180.

### Using the RPPR function to record on multiple MIDI tracks simultaneously

You can use multi-recording to simultaneously record a multi-track performance using the RPPR function. For details, please see “Using RPPR (Realtime Pattern Play/Record)” on page 97.

### Recording multiple MIDI tracks from an external sequencer

#### 1. Make sure that the MIDI OUT of your external sequencer is connected to the MIDI IN of the M3.

If it is not connected, turn off the power, make the connection, and then turn the power on.

For details, please see “MIDI applications” on page 614 of the Parameter Guide.

#### 2. In the Global P1: MIDI- MIDI Basic page, set MIDI Clock to External MIDI. With this setting, the M3 will synchronize to MIDI clock messages from your external sequencer.

Make sure that **Receive Ext. Realtime Commands** is checked.

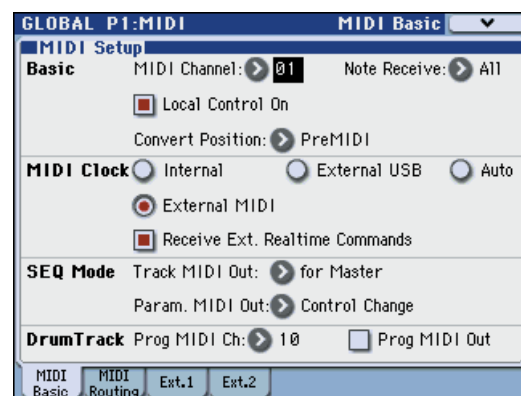

#### 3. Create a new song in Sequencer mode, and in the P0-1: Play/REC- Preference page, check the Multi REC check box. Set Recording Setup to Overwrite.





#### 4. Press Play/Rec/Mute to select “REC” for the tracks you want to record.

For the tracks you don't want to record, select Play or Mute.

*Tip:* You can also control the Play/Rec/Mute setting from the front panel mixer section, or from the P0-2: Play/REC- Control Surface page. For details, please see “Control using the sliders and switches” on page 82.



#### 5. In the P3: Track Param- MIDI T01-08 and T09-16 page, use MIDI Channel to specify the MIDI channel of each track.

Set the MIDI channel of each M3 track to match the MIDI channel of each external sequencer track. Data of the matching channel will be recorded on each M3 track.

Make sure that **Status** is set to INT or BTH.

#### 6. Press the LOCATE switch to set the location to 001:01.000.

#### 7. Press the SEQUENCER REC/WRITE switch to enter record-standby mode.

#### 8. Start your external sequencer.

The M3's sequencer will automatically begin recording when it receives the MIDI Start message transmitted by your external sequencer.

#### 9. When playback has ended, stop your external sequencer.

The M3's sequencer will automatically stop recording when it receives the MIDI Stop message transmitted by the external sequencer. You can also stop recording by pressing the SEQUENCER START/STOP switch of the M3.

After this, you can play back the newly recorded sequence:

#### 10. In the Global P1: MIDI- MIDI Basic page, set MIDI Clock to Internal.

Set **Tempo Mode** to Auto in the Seq P0-1: Play/REC- Program T01-08 page.

Press the SEQUENCER START/STOP switch to play back.

*Note:* If the correct sounds are not selected when you start playing back, you may be able to solve the problem by using the menu command **Event Edit** (P6: Track Edit) to re-specify the Program Change data.

## Recording System Exclusive events

Exclusive messages received from an external MIDI device or the parameter changes produced when you edit a MIDI track parameter or effect parameter can be realtime-recorded on any MIDI track.

During playback, the exclusive messages you recorded will control the track parameters and effect parameters of the song, and can be sent to external MIDI devices.

*Note:* You can use the menu command **Put Effect Setting to Track** to insert an exclusive event containing the parameter settings for an insert effect, master effect or total effect into the desired location of a track, so that these settings will automatically switch during playback.

**MIDI** GM, XG, and GS exclusive messages can be recorded on a track, but the M3's tone generator will not respond to these messages.

## Recording internal parameter changes

You can use SysEx for automation of internal M3 effects and Program parameters.

As an example, let's record a short phrase on track 1, add an insert effect, and then record parameter changes for that effect on an unused track.

*Note:* In order to record system exclusive messages, make sure that the Global P1: MIDI- MIDI Routing setting **Enable Exclusive** is checked. Go to Global mode and verify that this is checked.

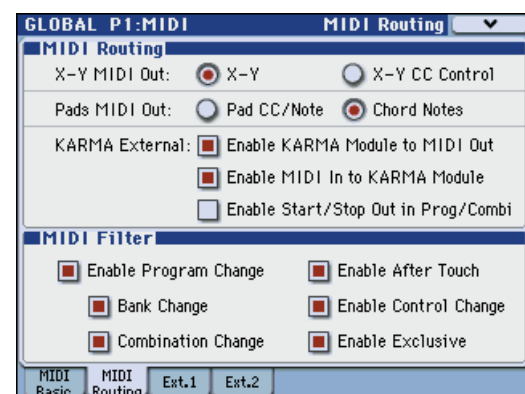

#### 1. Select the desired program for MIDI track 1, and route it to IFX1. Then record a phrase of about sixteen measures.

- In the P0-1: Play/REC- Program T01-08 page, use “Program Select” to select the desired program for MIDI Track 01.

- In the P8-1: IFX- Routing1 T01-08 page, route the MIDI Track 01 **Bus Select (IFX/Indiv. Out Assign)** to IFX1. Then in the P8-1: IFX- Insert FX Setup page, select the desired effect for IFX1.
  - Select MIDI Track 01 in **Track Select**. Then press the SEQUENCER REC/WRITE switch and then the START/STOP switch, and record a phrase of about sixteen measures.
2. **Select Track 09 in “Track Select,” and record parameter changes as desired.**

*Note:* For this example, select an empty track. If you want to record onto a MIDI track that already contains data, set the P0-1: Play/REC- Preference page **Recording Setup** to “Overdub,” as described on page 86.



- Select Track 09 in **Track Select**. Then press the SEQUENCER REC/WRITE switch and then the START/STOP switch, and begin recording.
- At the appropriate time while recording, adjust the parameter(s) that you want to realtime-record.

Select another effect for IFX1 in the P8-1: IFX- Insert FX Setup page, and edit the effect parameter values, or use the P0-2: Play/REC- Control Surface page Tone Adjust controls to edit the sound in realtime.

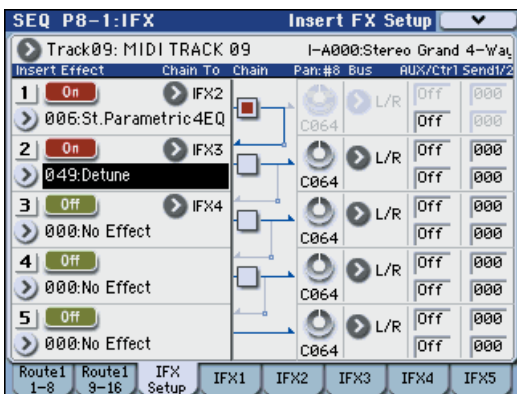

*Note:* For details on the effects parameters that you can record in real-time, please see “System Exclusive events supported in Sequencer mode” on page 295 of the Parameter Guide.

### 3. Stop recording.

*Note:* Exclusive messages are always recorded on the current track selected by **Track Select**. In this example, they are recorded on MIDI track 9.

*Note:* In the MIDI event edit page you can view the recorded exclusive events and their location. Exclusive events are displayed as “EXCL”.

To view these events, go to the P6: Track Edit- Track Edit page, and select the menu command **MIDI Event Edit**. Then in the Set Event Filters dialog box, check **Exclusive** and press the OK button.

Exclusive events cannot be changed to a different type of event. Nor can other events be changed into exclusive events.

4. **If you go to the page (e.g., P8-1: IFX) that shows the parameters you adjusted in realtime, you can watch the recorded changes be reproduced while the song plays back.**

### Exclusive messages that can be recorded in real-time

The following exclusive messages can be recorded in real-time:

- Exclusive messages received from an external MIDI device
- Parameter changes in Sequencer mode (see “System Exclusive events supported in Sequencer mode” on page 295 of the Parameter Guide)
- Master Volume universal exclusive messages assigned to the foot pedal or a slider

### Using the control surface to record changes in the pan, EQ, volume, and tone adjust settings of a MIDI track

While performing realtime recording, you can use the control surface to modify the pan, EQ, volume, and tone adjust settings to record these changes so that they will be reflected during the playback.

Use multi-track recording if you want to modify the settings of multiple tracks simultaneously.

*Note:* Control you perform using the control surface is transmitted as control change messages and system exclusive messages. In order for this data to be recorded, the Global P1: MIDI- MIDI Routing **Enable Control Change** and **Enable Exclusive** settings must be checked. Go to Global mode and verify that these items are checked.

*Note:* Use **Param. MIDI Out** to specify whether control change messages or system exclusive messages will be transmitted when you edit the Pan (CC#10), Volume (CC#7), or Send 1/2 level (CC#93 and CC#91) parameters.

In this case, the Global P1: MIDI- MIDI Routing settings **Enable Control Change** and **Enable Exclusive** must be checked respectively.

## Recording patterns

### Recording and editing patterns

You can record patterns in either of two ways; realtime recording or step recording. However, pattern realtime recording differs from song realtime recording in that you can use only Loop type recording.

You can edit patterns by using Event Edit operations to modify the recorded data or insert new data. You can also use the **Get From Track** menu command to convert a desired region of performance data from a MIDI track into a pattern. Conversely, you can use the **Put to Track** or **Copy to Track** menu commands to place or copy the performance data from a pattern into a MIDI track.

### Recording patterns in real-time

Here's how you can use realtime recording to create a pattern. User patterns can be accessed by the RPPR function in the same way as preset patterns, and can be copied to or placed in a song. Playback data from a track can also be copied to a pattern.

In addition, you can use the menu command **Convert to Drum Trk Pattern** to convert a user pattern to a user Drum Track pattern for use with the Drum Track function. (See "Pattern" on page 96)

When realtime-recording a pattern, a pattern of the specified number of measures will playback repeatedly, allowing you to continue adding musical data to it.

1. Create a new song, and as described in "Preparations for recording" on page 83, set the track to the program that will be used by the pattern.
2. Access the P10: Pattern/RPPR- Pattern Edit page.

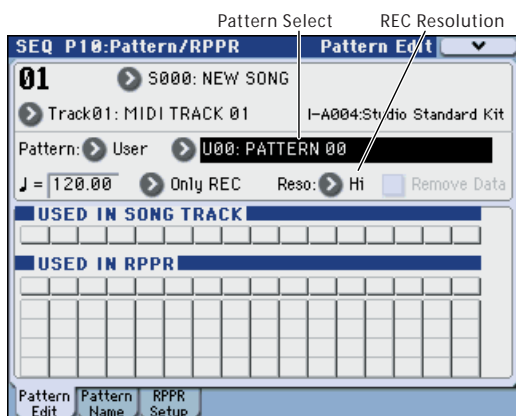

3. Use **Track Select** to select the track that you will use to record the pattern.

The pattern will sound with the program and other settings of the selected track.

4. Set "**Pattern (Pattern Bank)**" to **User**, and set "**Pattern Select**" to **U00**.

User patterns U00-U99 can be created for each song.

5. Select the menu command "**Pattern Parameter**".

A dialog box will appear.

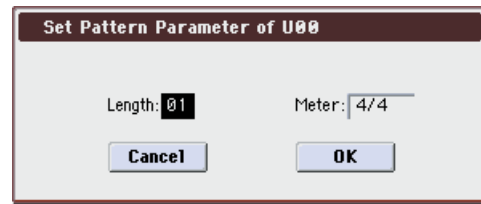

6. Set the number of measures in the pattern to a "Length" of 04 (four measures), and set "Meter" to a time signature of 4/4. Press the OK button.

7. As necessary, set "REC Resolution" to apply realtime quantization.

8. Begin realtime recording.

You can record in the same way as you did when recording tracks with Loop All Tracks. (See "Loop All Tracks" on page 86)

Press the SEQUENCER REC/WRITE switch, and then press the SEQUENCER START/STOP switch.

After the pre-count, pattern recording will begin. Play the keyboard and operate the joystick and other controllers to record your performance.

When you reach the end of the pattern, the sequencer will return to the beginning of the pattern and continue recording. If you continue recording, the newly recorded data will be added to the previously-recorded data.

9. If you want to delete specific data while you continue pattern recording, you can press the SEQUENCER REC/WRITE switch or check the "Remove Data" check box.

For details refer to step 6 of "Loop All Tracks" on page 86.

10. Press the SEQUENCER START/STOP switch to stop recording.

If you made a mistake or decide to re-record, press the SEQUENCER START/STOP switch to stop recording, and press the COMPARE switch. Then begin the pattern recording procedure again as in step 8.

### Control data in pattern recording

To record control data in a pattern, you should restore the control data to its normal value within the pattern. If you fail to restore the normal value, unnecessary control data may remain in a "stuck" position when you place the pattern in a song or use the RPPR function to play the pattern. However, the following control data will be automatically reset to the following values when the song or RPPR function finishes playing the pattern, or when playback is halted.

Controller	Reset value
Modulation 1 (CC#01)	00 (zero)
Modulation 2 (CC#02)	00 (zero)
Expression (CC#11)	127 (max)
Ribbon controller (CC#16)	64 (center)
Damper switch (CC#64)	00 (zero)
Sostenuto switch (CC#66)	00 (zero)
Soft switch (CC#67)	00 (zero)
EG sustain level (CC#70)	64 (center)
Resonance level (CC#71)	64 (center)
EG release time (CC#72)	64 (center)

Controller	Reset value
EG attack time (CC#73)	64 (center)
Low pass filter cutoff (CC#74)	64 (center)
EG decay time (CC#75)	64 (center)
LFO1 speed (CC#76)	64 (center)
LFO1 depth (pitch) (CC#77)	64 (center)
LFO1 delay (CC#78)	64 (center)
Filter EG intensity (CC#79)	64 (center)
SW1 modulation (CC#80)	00 (zero)
SW2 modulation (CC#81)	00 (zero)
Channel aftertouch	00 (zero)
Pitch bender	00 (zero)

### Using KARMA for pattern recording

If the KARMA function is set to operate for the track that is selected for **Track Select**, and record the performance of the KARMA function into the pattern.

## Song editing

You can apply a variety of editing operations to a song. The available types of editing operation are listed below.

---

### Song

**Delete Song:** This command deletes the currently selected song. For details, please see “Delete Song” on page 271 of the Parameter Guide.

**Copy From Song:** This command copies all of the setting data and musical data from the specified song to the currently selected song. For details, please see “Copy From Song” on page 271 of the Parameter Guide.

**FF/REW Speed:** This allows you to set the speed at which fast-forward or rewind will occur when you press the FF switch or REW switch. For details, please see “FF/REW Speed” on page 272 of the Parameter Guide.

**GM Initialize:** This command transmits a GM System On message to the Sequencer mode, resetting all MIDI tracks to the GM settings. For details, please see “GM Initialize” on page 273 of the Parameter Guide.

**Set Song Length:** This command changes the length of the specified song. When it is executed, the length of the master track will change, and the number of measures played will change. For details, please see “Set Song Length” on page 281 of the Parameter Guide.

---

### Tracks

**Step Recording:** It allows you to specify the length and velocity of each note numerically, and to input MIDI data, the pitches, from the keyboard. You can use the Rest button and Tie button to enter a rest or tie. For details, please see “Step Recording” on page 279 of the Parameter Guide.

**Event Edit:** Here you can edit individual events of MIDI data. For details, see “Event Edit” on page 280 of the Parameter Guide.

**Erase Track:** This command erases the data from the specified track. It is not possible to erase the master track by itself. For details, please see “Erase Track” on page 281 of the Parameter Guide.

**Copy Track:** This command copies musical data from the copy source track to the specified track. For details, please see “Copy Track” on page 281 of the Parameter Guide.

**Bounce Track:** This command combines the musical data of the bounce source and bounce destination tracks, and places the combined data in the bounce destination. All musical data in the bounce source will be erased. For details, please see “Bounce Track” on page 281 of the Parameter Guide.

**Erase Measure:** This command erases the specified type(s) of musical data from the specified range of measures. The Erase Measure command can also be used to remove only a specific type of data. Unlike the Delete Measure command, executing the Erase Measure command does not cause the subsequent

measures of musical data to be moved forward. For details, please see “Erase Measure” on page 282 of the Parameter Guide.

**Delete Measure:** This command deletes the specified measures. When the Delete Measure command is executed, the musical data following the deleted measures will be moved towards the beginning of the sequence. For details, please see “Delete Measure” on page 282 of the Parameter Guide.

**Insert Measure:** This command inserts the specified number of measures into the specified track. When you execute the Insert Measure command, the musical data following the insert location will be moved backward. For details, please see “Insert Measure” on page 283 of the Parameter Guide.

**Repeat Measure:** This command repeatedly inserts the specified measures for the specified number of times. When you execute the Repeat Measure command, the measures will be inserted following the measure specified by **To End of Measure**, and musical data following the inserted data will be moved backward. For details, please see “Repeat Measure” on page 283 of the Parameter Guide.

**Copy Measure:** This command copies the measures of musical data specified as the “From” source to the beginning of the measure specified as the “To” location. When you execute the Copy Measure command, the existing track data at the copy destination will be rewritten. For details, please see “Copy Measure” on page 284 of the Parameter Guide.

**Move Measure:** This command moves the specified measures of performance data to another measure. When you execute the Move Measure command, the performance data following the move-source measures will move forward by the corresponding number of measures, and the performance data following the move-destination will move backward (i.e., later in the song) by the same number of measures. For details, please see “Move Measure” on page 284 of the Parameter Guide.

**Create Control Data:** This command creates control change, aftertouch, pitch bend, or tempo data in the specified region of a MIDI track or the master track. For details, please see “Create Control Data” on page 284 of the Parameter Guide.

**Erase Control Data:** This command erases data such as control changes, aftertouch, pitch bend, or tempo in the specified range. For details, please see “Erase Control Data” on page 285 of the Parameter Guide.

**Quantize:** This command corrects the timing of MIDI data of the type you specify (note data, control change, aftertouch, pitch bend, program change, etc.) in the track. You can also adjust for swing. For details, please see “Quantize” on page 285 of the Parameter Guide.



**Shift/Erase Note:** This command shifts (moves) or erases the specified note numbers in a specified MIDI track and range of measures. For details, please see “Shift/Erase Note” on page 286 of the Parameter Guide.

**Modify Velocity:** This command modifies the velocity values of notes in the specified area so that they will change over time according to a selected curve. For details, please see “Modify Velocity” on page 287 of the Parameter Guide.

---

## Pattern

**Step Recording (Loop Type):** Here you can perform step recording into a pattern. For details, please see “Step Recording (Loop Type)” on page 289 of the Parameter Guide.

**Event Edit:** Here you can edit individual events of the musical data in a pattern. For details, please see “Event Edit” on page 289 of the Parameter Guide.

**Pattern Parameter:** This command specifies the number of measures and the time signature of the selected pattern. For details, please see “Pattern Parameter” on page 289 of the Parameter Guide.

**Erase Pattern:** This command erases the data from the selected pattern. For details, please see “Erase Pattern” on page 290 of the Parameter Guide.

**Copy Pattern:** This command copies the settings and musical data of the selected pattern to another pattern. For details, please see “Copy Pattern” on page 290 of the Parameter Guide.

**Bounce Pattern:** This command combines the musical data of the bounce source pattern and bounce destination pattern, and places the combined musical data in the bounce destination. For details, please see “Bounce Pattern” on page 290 of the Parameter Guide.

**Get From Track:** This command takes musical data from a MIDI track and loads it into the specified pattern. For details, please see “Get From Track” on page 290 of the Parameter Guide.

**Put To Track:** This command places a pattern into a MIDI track. For details, please see “Put To Track” on page 290 of the Parameter Guide.

**Copy To Track:** This command copies the specified area of musical data from the specified pattern to a MIDI track as musical data. For details, please see “Copy To Track” on page 291 of the Parameter Guide.

**Convert to Drum Trk Pattern:** Converts the specified pattern to a user Drum Track pattern. For details, please see “Convert to Drum Trk Pattern” on page 291 of the Parameter Guide.

**Load Drum Track Pattern:** Loads the specified user Drum Track pattern into a user pattern. For details, please see “Load Drum Track Pattern” on page 292 of the Parameter Guide.

## Using RPPR (Realtime Pattern Play/Record)

This section explains how to assign a pattern to a key, and how to record and play an RPPR based performance.

### Creating RPPR data

1. Create a new song, and choose a drum program for MIDI track 1.
2. Access the P10: Pattern/RPPR– RPPR Setup page. In this page, the RPPR function is automatically turned on.
3. Select the key to which the pattern will be assigned.
4. Select C#2.

Hold down the ENTER switch and play a key.

*Note:* C2 and lower keys are used to stop playback, and cannot be assigned.

5. Check “Assign” for C#2.
6. Set “Pattern Bank” to Preset, and set “Pattern Select” to P00.
7. Set “Track” to Track01.

The selected pattern will be played according to the settings (program, etc.) of the track you select here.



8. Assign patterns to other keys.

For “KEY,” press the  $\Delta$  switch to select D2.

9. Press the Revert button.

The Assign, Pattern Bank, Pattern Select, and Track settings will be given the previously (steps 5–7) specified values.

10. Choose “Pattern Select,” and press the  $\Delta$  switch to select P01.

By using Revert in this way, you can work efficiently when assigning contiguous (or nearby) pattern numbers or tracks.



- As described above, assign several other patterns such as P03 and higher.

11. Press the C#2 key.

The assigned pattern will play.

12. Take your finger off the C#2 key, and press the D2 key.

The pattern will change, and playback will begin. At this time, the pattern operation will depend on the Sync and Mode setting.

13. Set KEY to C#2, and set Sync to Measure. Make the same setting for D2 (See the diagram above).

Now press the notes consecutively. Notice that the patterns operate in a different way.

With the Measure setting, patterns will be handled in one-measure units. The second and subsequent patterns will start in sync with the end of previously played pattern.

If you change the Mode setting to Once, the entire pattern will playback to the end even if you release your finger from the keyboard immediately.

- To stop playback, either press the same key once again, or press the C2 or lower key.

For details on Sync, Mode, and Shift, please see PG page 267.

- The assigned keys are also shown in the keyboard graphic in the display.
- Keys to which no pattern is assigned can be played normally. Use Track Select to select the track you want to play. For example you could assign backing patterns for drums or bass to keys C#2–B2 and use these keys to control the pattern playback, while using the keys C3 and above to play a solo performance in realtime. It’s a good idea to keep your RPPR assignments within a specific range of keys.

## RPPR playback

Let's use the RPPR you created to perform in the P0-1: Play/REC- Program T01-08 page.

1. Access the P0-1: Play/REC- Program T01-08 page.



2. Check the "RPPR" check box.

The RPPR function will be turned on. Set the on/off for each song.

3. Play the keyboard, and patterns will begin playing according to the RPPR settings.

If you wish to trigger the RPPR function from an external MIDI device, use the MIDI channel that is selected for **Track Select**.

- Pattern playback for a key with a **Sync** setting of Beat or Measure will sync to the playback of the first pattern.
- If you are playing the pattern in synchronization (when **Sync** is Beat, Measure, or SEQ), the pattern will start accurately if you play the note slightly earlier than the timing of the beat or measure. Even if you play the note slightly later than the beat or measure (but no later than a 32nd note), it will be considered to have started at the beat or measure, and the beginning of the pattern will be compressed so that the remainder of the playback will be correct.

4. To turn off the RPPR function, uncheck the RPPR check box.

## Play RPPR while a song plays back

RPPR can be played in synchronization with the playback of a song.

Pattern playback for a key with a **Sync** setting of SEQ will synchronize to the playback of the song. (See "Sync" on page 215 of the Parameter Guide) Start the song playback, and then press the key. The pattern playback will start in synchronization with the measures of the song.

⚠ Synchronization will be lost if you use the << REW or FF >> switches while a song is playing.

*Note:* If you want RPPR pattern playback to begin at the moment that song playback begins, it is a good idea to insert an empty measure containing no musical data before the song playback begins.

*Note:* If the song is stopped, the pattern will synchronize to the timing of the KARMA function.

## Recording an RPPR performance

You can record RPPR performances in real-time.

If you are using only one track (such as MIDI Track 01), set **Track Select** to the desired track, and un-check **Multi Rec**.

On the other hand, even if RPPR uses only one track, use multi-track recording if you will be selecting another track in **Track Select** and recording its performance at the same time.

You should also select multi-track recording if you specified the RPPR data using multiple tracks rather than just a single track, and want to simultaneously record the performance of multiple tracks.

*Note:* The RPPR pattern will be recorded as performance data on the tracks used by the pattern.

In this example, we'll explain how you can record an RPPR performance and a keyboard performance at the same time. Before you continue, use the P0-1: Play/REC- Program T01-08 page to assign a drum program to MIDI track 1, and a bass program to MIDI track 2.

1. Assign several keys starting with C#2 to preset patterns.

Check the C#2 **Assign** setting, and set **Pattern Bank** to Preset and **Pattern Select** to the desired preset pattern. For **Track Name**, select MIDI track 1 (T01) to which you assigned a drum program.

2. For each RPPR pattern, set **Sync** to SEQ.

With a setting of SEQ, patterns played by the RPPR function while the sequencer is playing or recording will start in synchronization with the measures of the sequencer.

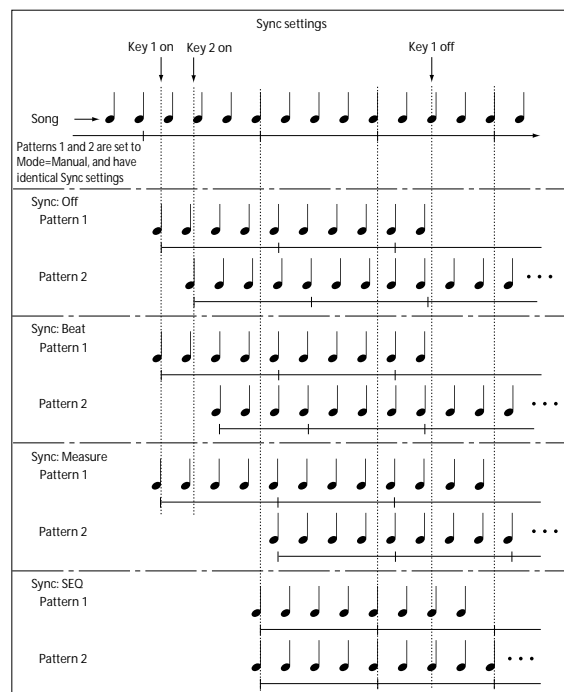

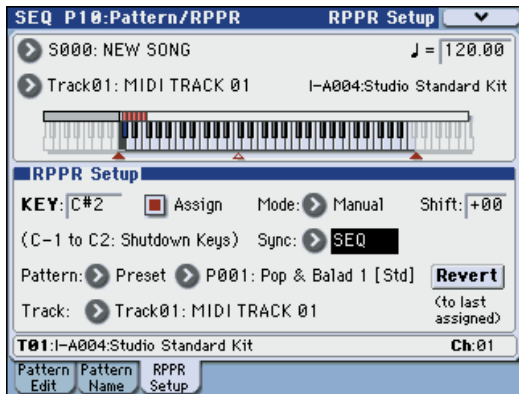

3. Access the P0-1: Play/REC- Program T01-08 page.
4. Check the “RPPR” check box, and set Track Select to MIDI Track 02.

When the RPPR function is on, pressing a key to which a pattern is assigned will cause the assigned pattern to start playing, regardless of the track that’s selected in Track Select.

Keys to which patterns are not assigned can be played in the usual way. You can play the program that’s assigned to the MIDI track you select here.



5. Since you want the tracks you play via RPPR and the track you play from the keyboard to be recorded at the same time, check the Multi REC check box. (See page 87)

*Note:* If Recording Setup is set to Loop All Tracks, it will not be possible to select Multi REC. Set the Recording Setup to Overwrite.

6. Press the SEQUENCER REC/WRITE switch to enter record-ready mode.
7. For the tracks you will be recording (MIDI Track 1, 2), press Play/Rec/Mute to make them indicate REC.

Make sure that the tracks you’re not recording are indicated as Play or Mute.

8. Press the LOCATE switch to set the location to 001:01.000.
9. Press the SEQUENCER START/STOP switch, and then press a key that plays an RPPR pattern.

If, during the pre-count before recording, you press a key that’s assigned to an RPPR pattern, the pattern will begin playing (and being recorded) the moment that recording begins.

Record the RPPR pattern playback and keyboard performance.

⚠ When recording the playback of patterns triggered by RPPR, the timing of the recorded events may be slightly skewed. If this occurs, try setting REC Resolution to a setting other than Hi.

10. When you are finished performing, press the SEQUENCER START/STOP switch.

Recording will end, and the sequencer will return to the location at which recording began.

If you made a mistake during your performance or would like to re-record, you can use the Compare function (press the COMPARE switch) to re-record as many times as you wish.

11. If you want to record other tracks, un-check the Multi REC (See step 5) or “RPPR” (See step 4) check boxes as necessary.

## Sampling in Sequencer mode

Sampling is still available in Sequencer mode - which can be very convenient. The main areas of functionality are summarized below. For details, please see “Sampling in Program, Combination, and Sequencer modes” on page 122.

- Multisample etc. you create can be played back in Sequencer mode together with internal programs. The Time Slice function of Sampling mode lets you divide up a rhythm loop sample, and create playback data that triggers the divided samples at the appropriate timing. You can play back this performance data in Sequencer mode, and adjust the playback tempo without affecting the pitch of the rhythm loop sample. You can even exchange the note numbers of the performance data or change its timing to transform the original rhythm loop sample into a completely new rhythm loop. For details, please see “Time Slice” on page 343 of the Parameter Guide.
- The In-Track Sampling function lets you sample an external audio source that’s playing along with the song playback, and automatically create note data in the track to play this sample at the correct time.
- You can resample your completed songs to WAVE files, and create an audio CD by burning those WAVE files in Media mode. For details, please see “In-Track Sampling” on page 126.

### Settings for sampling/resampling

The menu command **Auto Sampling Setup** lets you automatically make the necessary settings for sampling/resampling (e.g., In-Track Sampling) or for a two-channel mix for creating an audio CD. For details, please see “Tip: Auto Song Setup” on page 192 of the Parameter Guide.

- **Initialize:** Set parameters related to sampling to their default values.
- **Resample SEQ Play:** Make settings so that you can resample your keyboard playing in Sequencer mode.
- **In-Track Sampling:** Make settings to sample only an external audio signal using the In-Track Sampling function.
- **2ch Mix to Media:** Make the appropriate settings for resampling a completed song to create a stereo two-channel WAVE file on an external USB storage device (such as a hard disk). (After creating the WAVE file, you can use the Media mode Make Audio CD page to create an audio CD on an external USB CD-R/RW drive.)



# Creating and playing a Cue List

A cue list allows you to play multiple songs in succession. For example you can create a separate song for each portion (introduction, melody A, melody B, chorus, and ending) of a composition, and use the cue list to specify the order of each portion and the number of times that it will be repeated to complete the song. If you want to change the structure of the song, the cue list lets you do so in an efficient way.

You can also use this as a jukebox function that will playback completed songs in the order you specify.

Step	Song	Repeat
01	S000: Intro	02
02	S001: A	02
03	S002: B	01
04	S003: Chorus	02
05	S001: A	02
06	S002: B	01
07	S003: Chorus	02
08	S001: A (Solo)	01
09	S003: Chorus	03
10	S004: Ending	02

Intro	Intro	A	A	B	Chorus
Chorus	A	A	B	Chorus	Chorus
A(Solo)	Chorus	Chorus	Chorus	Ending	Ending

### 3. Set the last step to End.

If you set this to Continue to Step01, the cue list will play back repeatedly.

### 4. In "Repeat," specify the number of times that the song for that step will be repeated. For this example, set Step 02 S001: VERSE to 02.

### 5. Specify whether effect settings will also be switched when the song at each step is played back. If you want to effect settings to change, check the "FX" check box.

For this example, check the "FX" check box for Step 01, which loads the effects.

### 6. To play back at the tempo that was specified for each song, set "Tempo Mode" to Auto.

If this is set to Manu (Manual), playback will use the tempo specified by "J=".

## Creating a cue list

Each unit in a cue list is called a "step," and each step contains a song number and the number of repeats.

For example, suppose you've created the songs S000: INTRO, S001: VERSE, and S002: CHORUS. Let's use a cue list to connect these songs together.

### 1. Access the Seq P11: Cue List page.

With the default settings, song S000 will be selected for "Step" 01, and End will be selected for "Step" 02.

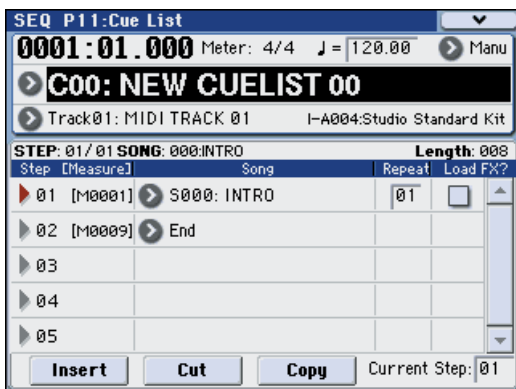

### 2. Add a song to the Step area.

Select the "Song" for Step 02, and press the Insert button. A song will be added to step 02. Use the VALUE controller to select S001: VERSE.

In the same way, select the Step 03 "Song," and press the Insert button to add a song to Step 03. Set this to S002: CHORUS.

If you press Cut button, the selected step will be deleted. If you press the Insert button, the deleted step will be inserted.

If you press the Copy button, the selected step will be copied. If you press the Insert button, the copied step will be inserted.

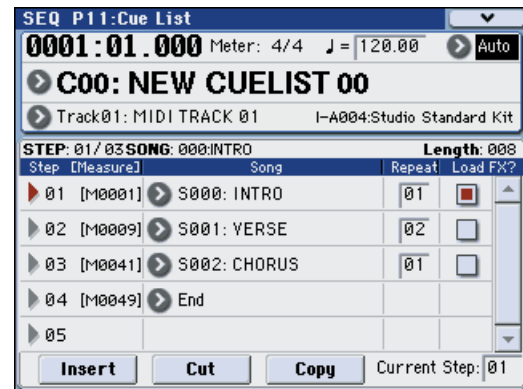

### 7. When you press the SEQUENCER START/STOP switch, playback will begin from the step that is specified as the "Current Step."

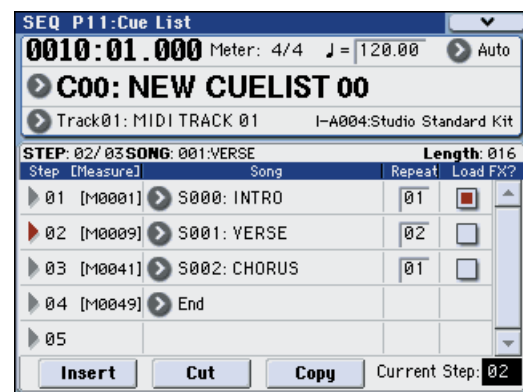

- **Step:** The arrow will indicate the currently playing step. ▶ indicates the currently selected "Step." If you set **Current Step** while stopped, the display will change.
- **M\*\*\*:** Indicates the starting measure of that step.
- **Meter:** Indicates the currently-playing time signature. This cannot be changed.
- The name of a cue list can be specified by the **Rename Cue List** menu command.
- When you play the keyboard, the program of the track selected by **Track Select** will sound. If a different program is selected for each song, the

program specified for the currently playing song will sound.

### What to do when playing back a cue list and the songs do not transition smoothly

If the effect settings differ between songs, and depending on the playback data within the song, there may be cases in which there is a time lag between songs during playback. Also, the playback data at the transition between songs may not play at the correct timing. In such cases, use **Convert to Song** to convert the cue list into a single song. When you play back this song, there will be no time lag at the transition, and the data will play at the correct timing.

If the effect settings differ between songs, and you want to smooth the transition between songs, check "FX" for Step 01. This way, the effect settings will be made before playback begins, and there will be no time lag when cue list playback is started or when switching from song to song. Although it will not be possible to change effect types within the cue list, you can use dynamic modulation or MIDI control changes such as Effect Control to control the effects within the cue list, for example applying reverb more deeply on certain songs, or raising the LFO speed for a specific song. We recommend this method if you will be using a cue list to construct the song.

When you execute the menu command **Convert to Song**, the effect settings of the "Step" 01 song will be specified for the song that results from the conversion.

Even if "FX" is not checked, there may be cases in which a time lag in the transition between songs, depending on the musical data of the song. Also, there may be cases in which the musical data is not played at the correct timing at the transition between songs. If this occurs, you can edit the musical data of the song, or convert the cue list to a song for playback. If you use **Convert to Song** to convert the cue list to a song, there will be no time lag during playback at the transition between songs, and the musical data will be played at the correct timing.

### Creating multiple songs for use in a cue list

If you want to create multiple songs for use in a cue list, it is a good idea to make the various necessary settings (program and other settings for each track, effect settings, etc.) for one song (e.g., S000), and then use the menu command **Copy From Song** in Seq 1.1 etc. to copy it to other songs so that the settings will be consistent.



⚠ After your cue list is finished and you convert it into a song, the track settings (program, pan, volume, etc.) of each step will be converted into playback data and will be reproduced, but if the MIDI channel settings from song to song do not

match, it may not be possible to convert the playback state of the cue list into a song.

### Using a foot switch to switch the Step

You can use a foot switch to switch the Step.

If you set **Repeat** to **FS**, a foot switch connected to the ASSIGNABLE SWITCH jack will control the timing at which the song stops repeating. Set **Foot Switch Assign** (Global P2: Controllers page) to Cue Repeat Control.

## Converting a cue list into a song

Although it is not possible to record additional material onto tracks in a cue list, you can convert a cue list to a song, and then record solos etc. on vacant tracks. You will also need to convert a cue list to a song if you wish to save it on a media as SMF data.

#### 1. Select the menu command "Convert to Song".

A dialog box will appear.

#### 2. In "To Song," specify the destination song number for the converted data.

The cue list name will automatically be assigned as the song name of the converted data. (For details and cautions regarding **Convert to Song**, please see "Convert to Song (Convert Cue List to Song)" on page 292 of the Parameter Guide.)

If you select a new song as the conversion destination, it is not necessary to specify **Set Length** in the dialog box that appears. The number of measures in the converted song will be used. Press the OK button, and the Convert Cue List dialog box will appear.

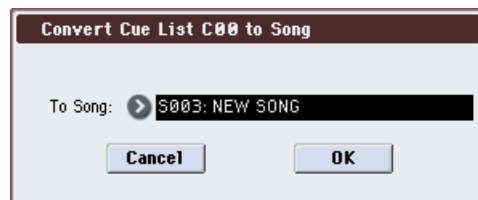

#### 3. Press the OK button.

The cue list will be converted into a song. Access the P0-1: Play/REC page, select the song number that you specified as the conversion destination, and check the results.



## Saving your song

Here we will explain how to save your song on a USB storage device (commercially available) connected to the USB A connector.

To ensure that your data will be reproduced perfectly, we recommend that you use **Save All** to save your song.

 When you turn off the power, the Sequencer mode settings, the recorded songs, and the user pattern data will be lost.

To save your data, proceed as follows.

1. **Make sure that the media is able to save data.** (“Setting up media”)
2. **Press the MODE MEDIA switch to enter Media mode.**
3. **Press the Save tab to access the Media- Save page.**
4. **Use “Media Select” to specify the save-destination.**
5. **If the drive contains directories, select the directory in which you want to save the data.**

Press the Open button to move to a lower level of the directory structure, or the Up button to move to a higher level.

If you want to create a new directory, move to the level at which you want to create the directory, and execute the Utility menu command **Create Directory**.

6. **Press the menu button to access the “Save All.” If you’ve chosen “Save All,” .PCG, .SNG, and .KSC files will be saved.**

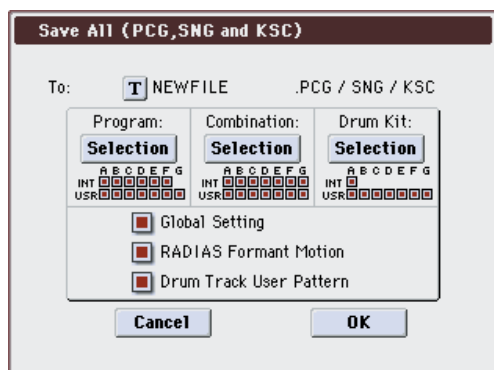

7. **Use the text edit button to enter the filename with which you want to save the data.**
8. **Press the OK button to execute the Save operation.**
9. **When saving is complete and you return to the Save page, the display will show the file that was saved.**

The various types of data are saved as the following files.

### .PCG file

Programs, combinations, drum kits, RADIAS formant motions, user Drum Track patterns and global settings from internal memory

### .SNG file

Sequencer song data, cue list and user patterns

### .KSC file

A file that lists the multisamples and samples

## Directory

The multisamples (.KMP files) and samples (.KSF files) listed in the .KSC file are stored within a directory on the media.

The data will be saved to the media you specified, and you will return to the Save page.

The time required for saving will depend on the amount of data.

If the media contains an identically-named file, you will be asked whether you want to overwrite the existing data. Press the OK button if you want to overwrite the data that’s already on the media. If you don’t want to overwrite the existing data, press the Cancel button, return to step 6, rename the data in step 7, and save it again.

## Saving a template song

If you want the programs, track parameters, effect settings, and KARMA settings etc. used by a song to be saved as a Template song, use the **Save Template Song** menu command to save these settings.

## Cautions and other functions in Sequencer mode

### M3 sequencer file formats

The M3 sequencer supports both the proprietary M3 Song format, and Standard MIDI Files.

If you like, you can convert data between the two formats, simply by loading the data in one format and then saving it in the other.

For details, please see “Save to Standard MIDI File” on page 411 of the Parameter Guide, and “Save SEQ” on page 410 of the Parameter Guide.

#### M3 Song format

This is the native M3 sequencer format, which is required to ensure that all M3-specific data is saved correctly.

#### Standard MIDI Files

You can also load and save Standard MIDI Files (SMF), for compatibility with other sequencers. Note that some M3-specific data may not be maintained when in SMF files.

#### GM, XG, and GS System Exclusive Data

The M3 sequencer can record System Exclusive messages, including XG or GS data. For details, please see “System Exclusive events supported in Sequencer mode” on page 295 of the Parameter Guide.

 Note that GM, XG, and GS exclusive messages do not affect the M3 when they are played back.

### The Compare function

When you perform realtime recording, step recording, or track editing, this function allows you to make before-and-after comparisons.

If you continue editing when the COMPARE switch is lit, the switch will go dark. This now becomes the musical data that will be selected when the COMPARE switch is dark. Any previous unsaved edits will be lost.

#### Operations for which Compare is available

In general, MIDI track and pattern event data can not be returned to its original state.

Comparing song parameters is possible only during song editing (when executing a menu command).

- Recording to a MIDI track
- Track Edit  
All commands except for the menu commands **Memory Status**, **Panel-SW Solo Mode On**, **Exclusive Solo**, **FF/REW Speed** and **Set Location** of the P6: Track Edit- Track Edit page.
- Recording to a pattern
- Pattern Edit  
All commands except for the menu commands **Memory Status**, **Panel-SW Solo Mode On**, **Exclusive Solo**, **Convert to Drum Trk Pattern**, **Erase Drum Track Pattern**, and **FF/REW Speed** of the P10: Pattern/RPPR- Pattern Edit page.
- Song Edit  
P0-P5 pages: menu commands **Delete Song** and **Copy From Song**

#### Comparing after sampling

The Compare operation will also apply to multisamples and samples that were sampled with **Convert to** enabled in “Select Bank & Sample No.,” as described on page 275 of the Parameter Guide. This means that if you want to re-do your sampling, you can press the COMPARE switch to return the multisample and samples to the state prior to sampling, and unwanted samples will not remain.

 The program will not be affected by the Compare, and will not return to its prior state.

#### Operations for which Compare is not available

- Editing song parameters
- Menu commands other than those listed under “Operations for which Compare is available,” above.

## Memory Protect

Before you record a track or pattern, or edit the musical data, you will need to turn off the memory protect setting in Global mode. For details, please see “Protecting the memory” on page 130.

## About MIDI

### Track status

You can specify whether each track will use the internal M3 sounds, or use an external MIDI tone generator.

When the Track **Status** (P2- MIDI page) is set to INT or BTH, operating M3's keyboard and controllers will sound and control M3's own tone generator.

When **Status** is set to EXT, EX2 or BTH, operating M3's keyboard and controllers will sound and control the external tone generator. (The MIDI channel of the external tone generator must match the **MIDI Channel** of the track that is set to EXT, EX2 or BTH.)

1	2	3	4	5	6	7	8
Keyboard	Keyboard	Keyboard	Keyboard	Keyboard	Keyboard	Keyboard	Keyboard
<b>Status</b>							
▶ BTH	▶ BTH	▶ BTH	▶ BTH	▶ Off	▶ INT	▶ EXT	▶ EX2
<b>MIDI Channel</b>							
01	02	03	04	05	06	07	08
<b>Bank Select (When Status=EX2)</b>							
000	000	000	000	000	000	000	000
000	000	000	000	000	000	000	001

If you wish to use the Sequencer mode of the instrument as a 16-track multi-timbral tone generator, select INT or BTH.

For details, please see “Status” on page 226 of the Parameter Guide.

### Synchronizing the sequencer with an external MIDI device

The record/playback tempo of M3's sequencer can be synchronized to an external MIDI device such as a sequencer or rhythm machine. For details, please see “Synchronizing the playback of the KARMA function, Drum Track function or sequencer” on page 622 of the Parameter Guide.





# Sampling (Open Sampling System)

## Sampling Overview

### About sampling

The M3 features Korg's Open Sampling System, which allows you to perform sampling and resampling not only in Sampling mode, but also in Program, Combination, and Sequencer modes with functionality that is optimized for each different mode.

- Audio signals from an external source connected to the AUDIO INPUT jacks or S/P DIF IN jacks will be sampled in stereo, with 48 kHz/16-bit resolution. Analog signals will be converted into digital data when they are sampled. Digital signals will remain in the digital domain as they are sampled.

*Note:* If the optional EXB-FW is installed, you'll be able to input digital signals from M3 Plug-In Editor running in your host application. For details, refer to the "M3 Editor/Plug-In Editor Manual" (PDF).

- Performances using the M3's filters, effects, KARMA function, and sequencer can be resampled.
- Audio signals from an audio CD can be extracted (ripped) directly in the digital domain.

These sampling/resampling operations can be performed into the M3's RAM memory or into a USB storage device (such as a commercially available hard disk) connected to the USB A connector.

### Sampling to RAM memory or a USB storage device

#### Sampling to RAM memory

If you want to use the sampled/resampled multisample or sample as a sound generator waveform in an EDS program or a drum kit, you should sample to RAM memory.

The M3 comes with 64 Mbytes of RAM built in, and you can install an optional EXB-M256 to add an additional 256 Mbytes. Of the 64 Mbytes of RAM, 512 bytes are used by the system, and will not be available for sampling.

The amount of sampling time depends on the amount of free RAM, as shown below:

*Free RAM and approximate sampling times*

Free RAM	Approximate Sampling Time (min:sec)	
	Mono	Stereo
64 MB	11:39	5:49
256 MB	46:36	23:18

- ⚠ The multisample and sample data in the RAM memory is not backed up when the power is turned off. If you wish to keep this data, you must save it onto a media before turning off the power.

When the power is first turned on, memory will not contain any multisample or sample data. You must first load previously-saved data before you can playback or edit any sample data.

#### Installing the optional EXB-M256

The EXB-M256 is a memory board with 256 MB (megabytes) of capacity.

In Sampling mode, you'll be able to select sample memory bank RAM2. Refer to the above table for the sampling times when using bank RAM2.

In addition, you'll be able to load sample files of various formats (KORG, WAVE, AIFF, AKAI (S1000/S3000), SoundFont 2.0), or load optional PCM expansion USB memory data.

For details on how to install the EXB-M256, please see "Specifications and options" on page 224.

#### Sampling to a USB storage device

If you sample/resample to a USB storage device (such as a commercially available hard disk) connected to the M3's USB A connector, the sample will be saved as a WAVE file.

You can load this sample (WAVE file) into the M3's RAM memory and use it as a sound generator waveform. Alternatively, if you've resampled a song you created on the sequencer, you can use the resulting WAVE file to create an audio CD by using a USB CD-R/RW drive (commercially available). Since this data is an ordinary WAVE file, you can also load it into your computer and use it for any purpose.

One sample file allows a maximum of 80 minutes (mono: approximately 440 Mbytes, stereo: approximately 879 Mbytes) of user sampling, whether mono or stereo.

### Sampling/resampling functionality in each mode

#### Sampling mode

1. Analog audio signals from a mic or audio device connected to the AUDIO INPUT jacks can be converted into digital signals and sampled.

You can also apply effects while sampling.

2. Digital audio signal from a digital audio device connected to the S/P DIF jack can be sampled directly.

You can also apply effects while sampling. The S/P DIF input/output jacks support sample rates of 48 kHz.

*Note:* If the optional EXB-FW is installed, you can also sample from the FireWire connector.

3. **Digital audio signals from an audio CD in a USB**  
A connected USB CD-R/RW drive (commercially available) can be sampled directly (“ripped”).

4. **Samples can be processed through effects and internally sampled again (“resampled”).**

You can use either “Auto” mode which automatically applies the specified effect processing to the sample you specify, or “Manual” mode which lets you play the sample manually with effects applied and resample your performance.

5. **You can view the sample waveform in the display, and modify it using a variety of waveform editing commands (menu commands), loop settings, time slice, and time stretch.**

**Program, Combination, Sequencer modes**

1. **You can resample a performance that uses the functionality (filters, effects, KARMA function, sequencer, etc.) of each mode.**

2. **You can sample external audio sources via the M3’s input jacks (see “Sampling mode” 1 and 2, above).**

At this time, you can mix the M3’s own performance with the audio signals from the external source and sample the combined result, or you can monitor the performance of the M3 while sampling only the external source from the input jacks.

3. **In Sequencer mode when you sample an external audio source that’s playing along with the song playback, note data will be automatically created in a track to trigger this sample at the appropriate moment in the song.**

This means that you can sample your vocal or guitar performance while playing back the sequencer. This is called the In-Track Sampling function.

**Sampling frequency and bit resolution**

As shown in the diagram, sampling reads the level of the analog signal at fixed intervals along the time axis, and stores the levels in memory as digital data.

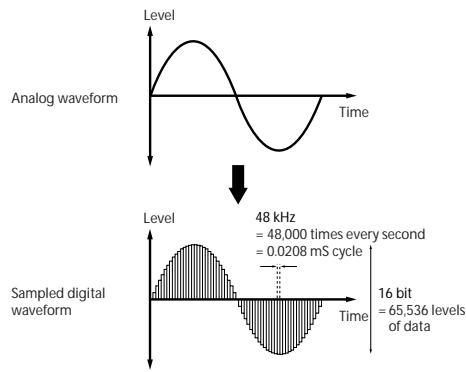

The “fixed intervals” mentioned above are generally expressed as the “sampling frequency.” 48 kHz (kilohertz) means that sampling is performed 48,000 times each second, and that the interval is 1 (second)/48,000 (times) = approximately 0.00002083 (seconds) = approximately 0.02083 mS (millisecond).

The higher the sampling frequency is, the closer to the original analog signal the waveform in memory will be.

Each level is read, and converted into digital data. The accuracy at this time is determined by the bit resolution. This process converts an analog signal with infinite resolution into a digital signal with finite resolution. With 16 bit resolution, each level is indicated in 65,536 steps (the sixteenth power of two).

The greater the bit resolution is, the closer to the original analog signal the waveform in memory will be.

48 kHz 16 bit sampling is the same quality as in audio devices such as DAT. A CD uses 44.1 kHz 16 bit sampling, which is a slightly lower sampling frequency.

**How Sampling mode is organized**

This section describes how sampling on the M3 is organized. (See the diagram below)

**Samples and Multisamples**

**Samples**

The data that is recorded (sampled) into internal memory or loaded from a file is referred to as a sample

Conceptual diagram of the Open Sampling System

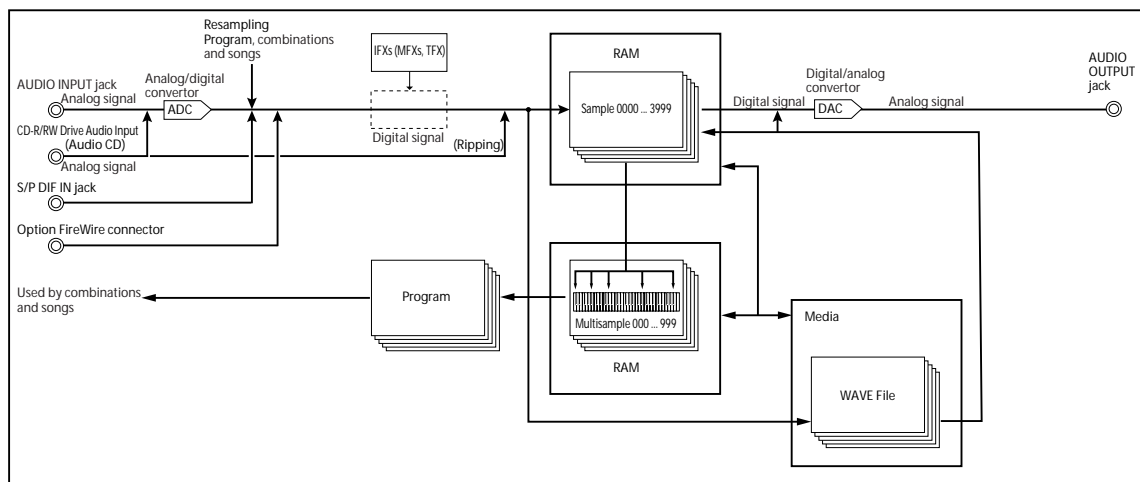

or sample file. Samples consist of the actual waveform data, and parameters that specify how the data will be played back, such as Start, Loop Start, and End Address. Samples can be used in multisamples and drum kits.

The M3 can hold a maximum of 4,000 samples in its internal memory.

The M3 can share a single waveform among multiple samples. This allows you to create multiple samples with different playback addresses from the same waveform without wasting internal memory. For example, suppose that you have waveform data that records a voice saying “One-Two-Three.” This single piece of waveform data could be shared by three samples, with the playback of sample A producing “One-Two-Three,” sample B producing “One-Two,” and sample C producing “Two-Three.”

For details, please see “Copy” on page 337 of the Parameter Guide.

## Multisamples

Multisamples lay out one or more Samples across the keyboard. For instance, a very simple guitar Multisample might have six Samples—one for each string.

Each Sample is contained in an Index, which includes parameters for the key range, original Sample pitch, tuning, level, and so on.

Multisamples can have up to 128 Indexes.

## Using multisamples

When sampling an instrument that is able to produce a wide range of pitches, such as a piano, recording just one sample and applying it (playing it back) over the entire pitch range will not produce a natural-sounding result. By using a multisample you can record separate samples for each pitch range, and assign these samples to their respective pitch ranges to avoid any unnatural sounds during playback.

All of the instrumental sounds in the M3’s internal preset multisamples are constructed in this way. For example, you might record one sample per octave, and assign each of these samples to an index (keyboard area).

By assigning multiple samples such as phrase samples or rhythm loops to a multisample and arranging them across the keyboard, you can play multiple samples simultaneously. You can assign different phrases to each key or pad. Alternatively, these samples could be assigned at one-octave intervals, and played as phrase variations with different playback pitches.

The M3 can hold a maximum of 1,000 multisamples in its internal memory.

A multisample can be selected as the oscillator for a program, and played as a program. In a combination, they can be combined with preset programs. They can be used with the KARMA function to produce interesting results (for example, by using the KARMA function to automatically play sound effects or spoken samples).

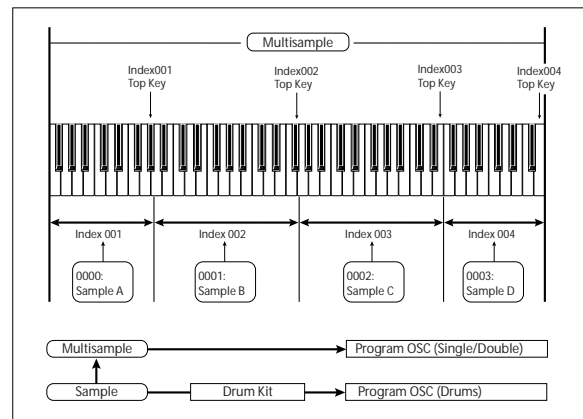

## Compare

In Sampling mode, there is no Compare function that lets you return to the state prior to editing.

If you want to preserve the state prior to editing, use a function such as **Copy Sample** or **Copy MS** to copy the multisample or sample before you begin editing. For details, please see “Copy Sample” on page 330 of the Parameter Guide, and “Copy MS (Copy Multisample)” on page 332 of the Parameter Guide.

In some of the menu commands on the Sample Edit and Loop Edit pages, you can execute with the “Overwrite” option unchecked in the dialog box, so that the sample data prior to editing will be preserved.

# Sampling and editing in Sampling mode

In Sampling mode, you can record samples, and edit sample data that you sampled or loaded from media (including WAVE and AIFF formats). You can also assign the edited samples to indexes (zones) to create a multisample.

*Sampling mode page structure*

	Page	Main content
RECORDING	P0: Recording	Record (sample) a sample. Select the sample or multisample to be recorded, make detailed settings for recording, make AUDIO INPUT settings, and view the memory status.
	P1: Sample Edit	Sample, or edit the waveform etc. of samples you loaded into internal memory using Media mode.
EDIT	P2: Loop Edit	Set playback parameters for samples, such as start, loop start, end address, loop on/off, and reverse playback on/off. Perform editing operations such as Time Slice and Time Stretch.
	P3: Multisample	Edit multisamples. Edit settings such as sample assignments, zones, and original key.
	P4: Controllers Setup	Controller settings.
CONTROLLER & AUDIO CD	P5: Audio CD	Play back or rip from an audio CD.
	P8: IFX	Bus and master effect send level settings. Insert effect routing, selection, and settings.
EFFECT	P9: MFX/TFX	Master effect routing, selection, and settings. Total effect selection and settings.

For details on how to access each mode and page, please see “Basic operations” on page 22.

Sampling can be performed in any page P0–P9 of Sampling mode by using the SAMPLING REC switch and the START/STOP switch. Recording-related settings such as input level are made by the parameters of P0: Recording, and these settings are valid for the other pages as well.

The selected multisample or sample can be played from the keyboard in any page, allowing you to hear the results of your editing in each page.

## Creating multisample indexes and sampling – P0: Recording

Here’s how to create indexes in a multisample, and assign a sample to each index.

1. Press the MODE SAMPLING switch to enter Sampling mode.
2. Access the P0: Recording– Recording page.

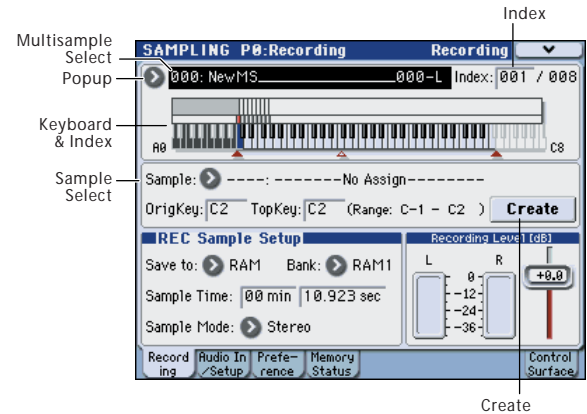

3. Select “Multisample Select,” and create a multisample.

To create a new multisample, press the “Multisample Select” popup button. Then press a Multisample No. in the list for which no name has been entered, or use the numeric keys 0–9 to input a number and then press the ENTER switch.

A dialog box will appear.



If you want to create a stereo multisample, check the **Stereo** box, and press the OK button.

If you want to create a monaural multisample, uncheck the **Stereo** box, and press the OK button.

4. Press the Create button to create an index.

Immediately after the power is turned on, “Index” will be 001/008. This indicates that there are eight indexes, and that the first index is selected.

Press the Create button several times. Each time you press it, an index will be created. The keyboard display will indicate the zone and original key location of each index.

*Note:* The index that is created when you press the Create button will be created according to the P0: Recording– Preference page **Create Zone Preference** settings. (These settings can also be made in P3: Multisample Edit page)



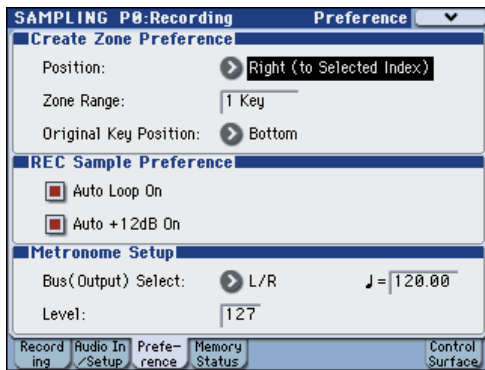

Immediately after the power is turned on, **Position** will be Right (to selected index), **Zone Range** will be 1 Keys, and **Original Key Position** will be Bottom, so that indexes will be created as shown below. This is convenient when you want to sample multiple takes of a phrase or rhythm loop in a single operation.



If you set **Zone Range** to 12 Keys, indexes will be created at intervals of one octave.

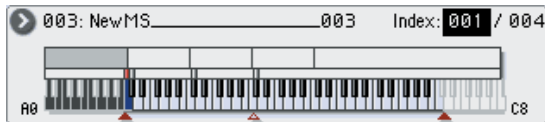

**5. Select “Index.”**

You can also select **Index** by holding down the ENTER switch and playing a pad or a note on the keyboard. For this example, select 001.

**6. Assign a sample to the “Index.”**

If RAM memory already contains samples, use **Sample (Sample Select)** to select the sample and assign it.

If you want to record a new sample, you can sample it now.

The sample you record will be automatically assigned to the index you selected in step 5.

The assigned sample will sound when you play the keyboard in the range of the index to which the sample is assigned.

**7. Repeat steps 5 and 6 to assign a sample to each index.**

The number and order of the indexes in a multisample, the range of each index, and the original key position can be freely changed later if desired.

(See “Multisample editing – P3: Multisample Edit” on page 119)

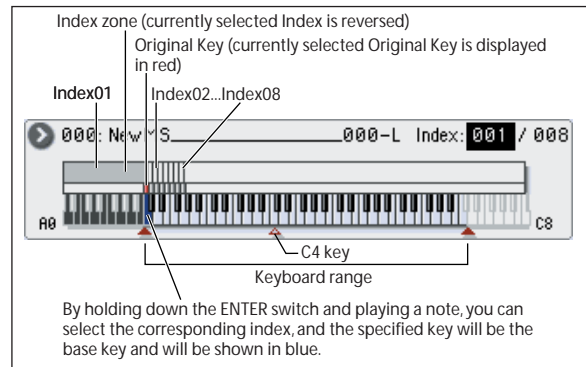

**Creating multiple samples**

In the example procedure described above, several indexes were created (by pressing the Create button several times), and then samples were assigned to each “Index.”

As an alternative method, it is also possible to create one index, sample into it, and then repeat these two steps.

1. Press the Create button once to create an index.
2. Record a sample.

The recorded sample will automatically be assigned to the index you created in step 1.

3. Repeat steps 1 and 2.

This is an efficient way to record multiple samples.

**Assigning samples to the pads**

By default, pads 1–8 correspond to the C2–G2 keys.

For example, the default “Index” setting for 001/008 sets **OrigKey** and **Top Key** to C2. The assigned sample will sound when you play the C2 key. The same sample will also sound when you strike pad 1. Similarly, if you assign samples to “Index” 002–008, the samples that sound when you play the C#2–G2 keys will also sound when you strike pads 2–8.

**⚠** In Sampling mode, you can’t use velocity to vary the volume even if PAD MODE is set to VELOCITY SENSITIVE.

For each pad, you can change the note numbers used to play samples.

These settings are made in the Sampling P4: Controllers– Pads 1–4 Setup, or Pads 5–8 Setup page. You could also assign the pads to pitch ranges that you are not likely to play. To make the setting, select the note number field, and play the desired key while holding down the ENTER switch.

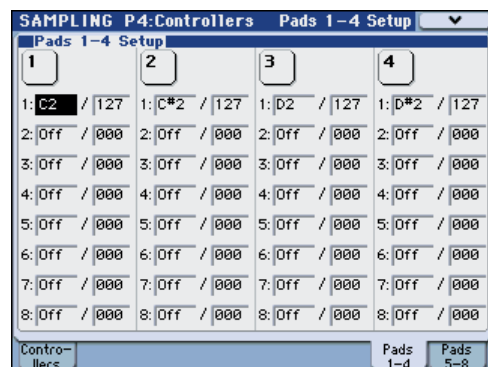

## Basic sampling procedure

### Sampling your voice from a mic, and playing it back as a one-shot sample

In this example we will use a mic connected to the AUDIO INPUT 1 jack to sample your voice in monaural.

#### Connect a mic and adjust the input level

1. Connect a mic to the rear panel AUDIO INPUT 1 jack.
2. Set the AUDIO INPUT MIC/LINE switch to the MIC position, turn the LEVEL knob to MIN, connect your mic, and then set the LEVEL knob to about the center position.

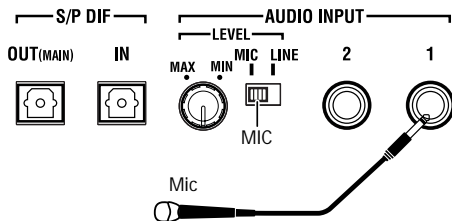

#### Sampling setup

1. Access the Sampling P0: Recording- Audio In/ Setup page.

Press the MODE SAMPLING switch to enter Sampling mode. Make sure that the Sampling P0: Recording page is displayed.

If this page is not displayed, press the EXIT switch to make the page appear, and then press the Audio In/ Setup tab.

2. Choose the menu command “Auto Sampling Setup”; the dialog box will appear.

“Auto Sampling Setup” automatically sets the parameters necessary for sampling in each mode. You’ll want to use these settings as a guideline when sampling.

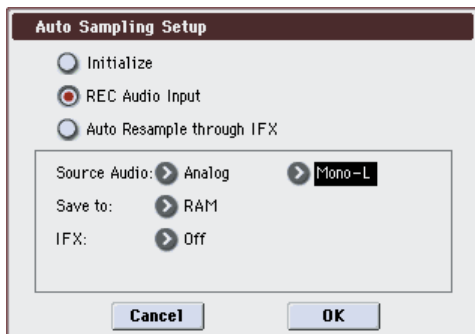

3. Select “REC Audio Input.”

This will make settings for sampling an external audio source.

4. Set “Source Audio” to Analog. This means that the instrument or other external audio input source connected to the AUDIO INPUT 1, 2 jacks will be sampled.

5. Set “Mono-L/Mono-R/Stereo” to Mono-L. With this setting, the input from the INPUT 1 jack will be sent to the internal L-channel and sampled in monaural.
  6. For the “Save to” field, select RAM. The sampled data will be written into RAM memory.
  7. Turn “IFX” Off. You will be sampling without applying an insert effect.
  8. Press the OK button to execute the command.
- You have now made the settings necessary for sampling.



Note: Take a look at the settings that have been made. Analog Input:

Input 1 Level: 127, Pan: L000  
BUS Select: L/R

Specify the input level from the INPUT 1 jack, set the pan, and choose the L/R bus as the destination.

**Source BUS:** L/R

The sound sent to the L/R bus will be sampled.

**Trigger:** Sampling START SW

Sampling will start when you press the SAMPLING START/STOP switch.

**Recording Level:** +0.0

This is the default setting for recording an external input.

**Save to:** RAM

You will be sampling to RAM memory.

**Sampling Mode:** L-Mono

The sound of the internal L channel will be sampled in mono.

9. Let’s change the “Trigger” setting which specifies how sampling will start. We’ll set it to make sampling start when the audio input exceeds a specified volume.

- Set **Trigger** to Threshold, and **Level** to -30 dB. Recording will start automatically when an audio input of -30 dB or greater occurs while in record-ready mode.
- Set **Pre Trigger** to 005 ms. Recording will begin from a point slightly (5 ms) before sampling starts, so that the earliest portion of the sound is not lost.

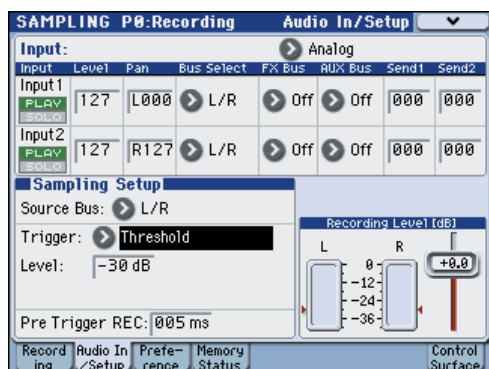

## Adjust the recording level

1. Use the rear panel LEVEL knob to adjust the level appropriately.

If the “ADC OVERLOAD !” (AD converter input overload) indication appears, turn the rear panel LEVEL knob toward MIN to adjust the level appropriately.

For the best sound, adjust the level as high as possible without allowing the “ADC OVERLOAD !” indication to appear.

2. Press the SAMPLING REC switch.

Speak into the mic, and notice that the level meter indicates the volume of the sound that will be recorded.

If the “CLIP !” indication appears, use the VALUE controller to lower the **Recording Level** slider (shown in the right of the display) from the +0.0 setting to an appropriate position.

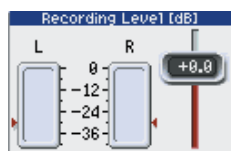

3. When you’ve finished making adjustments, press the SAMPLING REC switch.

## Record

1. Press the SAMPLING REC switch.

The M3 will be in record-ready mode.

2. Speak into the mic, saying the word(s) you want to sample.

(Example: “It’s”)

Recording will start when the level exceeds the **Level** -30 dB setting.

3. When you’ve finished saying the word(s), press the SAMPLING START/STOP switch.

This completes the sampling operation. The new sample will be automatically assigned to **Sample** (Sample Select).

## Hear the sampled result

1. The sample you just recorded will (by default) be assigned to **Index 001**.

When you press the **OrigKey** key (C2) for Index 001, you will hear the sound you just sampled.

You can also strike pad 1 to hear this sound.

Notice that the sample will loop (play repeatedly) if you hold down the key or pad. We’re going to turn looping off.

## Turn looping off

1. Access the **P2: Loop Edit** page.

Uncheck **Loop**. Now the sample will not loop even if you hold down the C2 key.

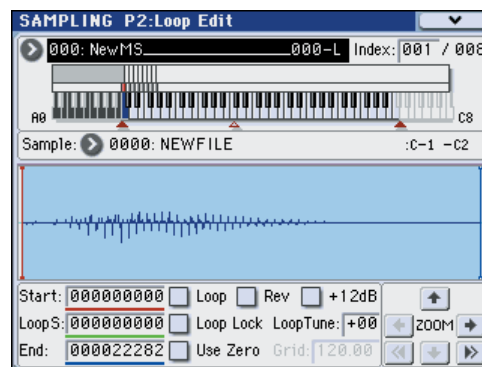

2. Now we’ll specify that looping will be turned off for each newly recorded sample.

Access the P0: Recording– Preference page.

Uncheck **Auto Loop On**.

If **Auto Loop On** is checked, the **Loop** setting will automatically be turned on when you sample, so that the sample will loop.

## Record the next sample

1. In the P0: Recording– Recording page, select “**Index**” and press the  $\Delta$  switch to select 002.
2. Press the SAMPLING REC switch and then the SAMPLING START/STOP switch.

Speak into the mic, saying the word(s) you want to sample.

(Example: “So”)

When you’ve finished speaking, press the SAMPLING START/STOP switch.

3. Repeat steps 1 and 2 several times more to record a few more samples.

(Example: “Easy,” “To,” “Sample,” “With,” “M3”)

## Listen to the recorded result

1. Play the keys one after another.

Play the keys starting at C2 in semitone steps. The samples you just recorded will play one after another.

(For example if you sequentially play the keys from C2 through F#2, you will hear “It’s So Easy To Sample With M3.”)

The multisample you created can be used as a program or combination. (See “Converting a multisample to a program” on page 120)

## Sampling from the S/P DIF input

In general, sampling from the S/P DIF inputs is very similar to sampling from the analog inputs. For instance, to record a stereo sample from the S/P DIF inputs, set up the sampling parameters as below:

**Source Bus:** S/P DIF IN L/R

**Resample:** Manual

**Recording Level [dB]:** as desired

**Mode:** Stereo

Important: Whenever using the digital inputs and outputs, make sure that the Global **System Clock** parameter is set correctly. For details, please see “System Clock” on page 359 of the Parameter Guide.

## Sampling external audio through insert effects

In this example, we’ll apply an insert effect to the sound from a mic connected to the AUDIO INPUT 1 jack, and sample the processed sound in stereo.

### Connect a mic and adjust the input level

1. Connect your mic to the rear panel AUDIO INPUT 1 jack, and adjust the input level. (See “Connect a mic and adjust the input level” on page 112)

### Execute the sampling setup

1. In the **SAMPLING P0: Recording– Audio In/Setup** page, choose the menu command “Auto Sampling Setup” to display the dialog box.

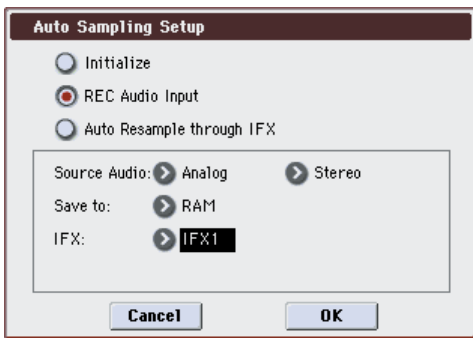

2. Select “REC Audio Input.”

Settings will be made for sampling an external audio source.

3. Set “Source Audio” to Analog. You’ll be sampling the analog audio output of an instrument or other external audio device connected to the AUDIO INPUT 1, 2 jacks.
4. Set “Mono-L/Mono-R/Stereo” to Stereo. The input from the INPUT 1, 2 jacks will be sent to the internal L, R channels and sampled in stereo.
5. Select RAM in the “Save to” field. The sampled data will be written into RAM memory.
6. Set “IFX” to IFX1.” You’ll be applying insert effect 1 while you sample.
7. Press the OK button to execute the command.

Settings for sampling have now been made.

*Note:* Take a look at the settings that were made.

Input 1 **BUS Select:** IFX1

The input level, pan, and send destination of the signal from the INPUT 1 jack are set to the IFX1 bus.

**Sampling Mode:** Stereo

You’ll be sampling the sound of the internal L, R channels in stereo.

Other settings are the same as step 8 of “Sampling your voice from a mic, and playing it back as a one-shot sample” on page 112.

### 8. We’ll make some minor changes to the settings.

Set the Input 1 **Pan** to C64.

This places the input signal in the center.

In addition, set **Trigger** to Threshold, **Level** to –30 dB, and **Pre Trigger** to 005 ms.

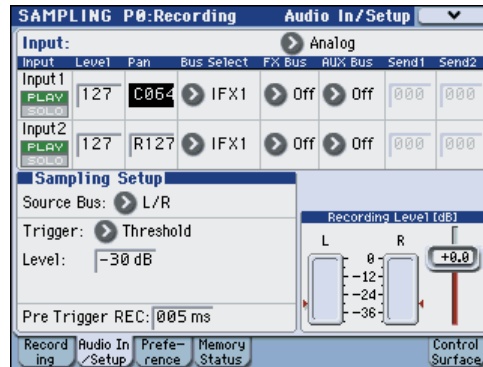

9. Access the **P8: IFX– Insert FX Setup** page.

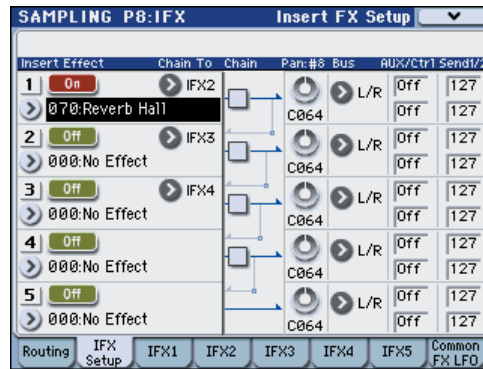

10. Select IFX1, use the numeric keys to input 7, 0 and press the ENTER switch to select 070: Reverb Hall.

Press IFX1 On/Off to turn it on.

11. Speak into the mic, and verify that reverb is applied.

You can use the IFX1 page to edit the effect settings.

12. Make sure that the Bus that follows IFX1 is set to L/R.

13. In the **P0: Recording– Recording** page, select **Index**.

If you want to create a new index, press the Create button.

### Adjust the recording level

For details, please see “Adjust the recording level” on page 114.

### Record

1. Press the **SAMPLING REC** switch, and then the **SAMPLING START/STOP** switch to enter record-ready mode.

Speak the word you want to sample.

Recording will start when the level exceeds the **Level** –30 dB setting.

2. Press the **SAMPLING START/STOP** switch to stop sampling.

## Check the sampled content

### 1. Play the keyboard.

Press the “OrigKey” key to hear the sound you sampled.

## Applying an insert effect to a sample and resampling the result

The process of applying an insert effect etc. to a sampled sound and then sampling it once again is called “resampling.”

### Automatic “resampling”

#### 1. In the P0: Recording– Recording page, assign the sample that you want to resample to Sample (Sample Select).

When the power is first turned on, the assigned sample will be set to Orig.Key C2.

#### 2. Select the menu command “Auto Sampling Setup.” A dialog box will appear.

#### 3. Choose “Auto Resample through IFX.” In “IFX,” select the effect you want to use.

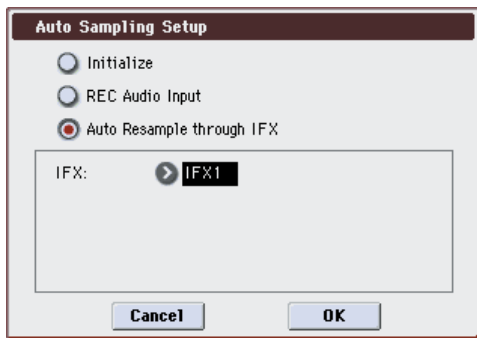

#### 4. Press the OK button to execute the command.

Settings for sampling have now been made.

#### 5. In the P0: Recording– Audio In/Setup page, use “Key” to specify the sample that you want to resample.

Normally you will set this to match the Orig Key of the Recording page.

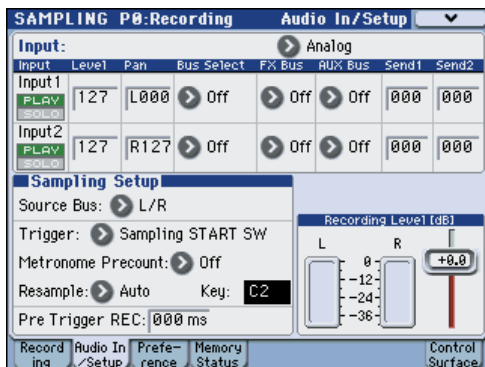

#### 6. In the P0: Recording– Preference page, make sure that “Auto +12 dB On” is checked.

#### 7. In the P8: IFX– Insert FX Setup page, set IFX1 to 070: Reverb Hall, and turn IFX On/Off ON.

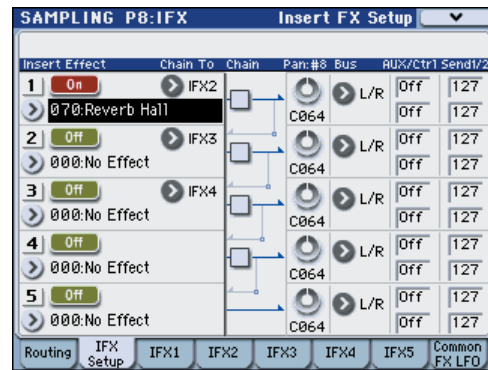

Play the note that’s specified for “Key,” and verify that reverb is applied.

Also make sure that the Bus following IFX1 is set to L/R.

#### 8. Press the SAMPLING REC switch, and then the SAMPLING START/STOP switch.

The sample assigned to Key will play automatically, and resampling will begin.

When the sample finishes playing, resampling will end.

The sample that was created by resampling will automatically be assigned to Sample Select.

*Note:* In Sampling mode, the P8: IFX– Routing page Bus (IFX/Output) Select parameter will automatically be set to L/R when resampling ends. This prevents an insert effect from being applied in duplicate when you monitor the results of resampling through an insert effect.

If you want to apply an insert effect once again, re-select IFX1.

### Parameter settings made by “Auto Resample through IFX”

- P0: Recording– Audio In/Setup  
**INPUT1 Bus Select:** Off  
 Turn off the input from the INPUT 1, 2 and S/P DIF L/R jacks.  
**Source Bus:** L/R  
 The sound sent to the L/R will be sampled.  
**Trigger:** Sampling START SW  
 After you’ve pressed the SAMPLING REC switch to enter sampling-ready mode, resampling will begin when you press the SAMPLING START/STOP switch.  
**Resample:** Auto  
 The sample assigned to the index will be resampled automatically.  
**Recording Level:** 0.0  
 This is the default setting for resampling.
- P0: Recording– Recording  
**Save to:** RAM  
 The data will be written to RAM memory.  
**Sampling Mode:** Stereo  
 The sound of the internal L/R channels will be sampled in stereo.
- P0: Recording– Preference  
**Auto +12dB On:** On  
 The +12 dB setting will automatically be turned on for the samples you record.



- P8: IFX- Routing  
Bus Select IFX1

⚠ Be aware that if you change the Bus Select setting from Off to L/R or IFX1-5, the volume level sent to the AUDIO OUT L/MONO and R jacks and the headphones may rise excessively.

### Manual “Resampling”

As an alternative to automatically resampling as described above (Automatic **Resampling**), you can simply sample the sounds that you play from the keyboard (Manual **Resampling**).

- In **Sample (Sample Select)**, assign the sample that you will resample, and set **Resample** to Manual. Set **Trigger** to Note On, and set **Sample Mode** to Stereo as desired. Then set **Source Bus**, P8: IFX- Routing **Bus Select** and effects, press the SAMPLING REC and START/STOP switches, and then press the key to which the sample you want to resample is assigned; resampling will begin. When you want to stop resampling, press the SAMPLING START/STOP switch.

## Loop Edit – P2: Loop Edit

You can edit the playback address at which the sample will be looped. The P2: Loop Edit page lets you do the following things.

- You can specify the looping addresses by editing **Start**, **End**, and **Loop Start** while watching the waveform. Functions like Zoom In/Out, Use Zero, and Grid make editing easy.
- You can turn looping on/off, adjust the tuning of the loop playback, apply a +12 dB playback boost, or reverse the playback.
- You can use the Time Slice function to automatically detect the attacks of kick and snare notes etc. in a rhythm loop sample (a looped sample containing a drum pattern), and automatically slice the sample at the appropriate locations. This function can automatically create performance data (notes) to play the divided samples at the appropriate moments, letting you play this phrase in Sequencer mode at the desired tempo without affecting the pitch of the individual notes. You can also do things like changing the pitch of just the snare drum, replacing it with an entirely different sample, or changing the playback timing of the phrase in the sequencer to transform the original rhythm loop into an entirely different rhythm loop. (Stereo samples are supported.) (See “Time Slice” on page 343 of the Parameter Guide)
- You can use the Time Stretch function to modify the tempo without changing the sample’s pitch. When executing Time Stretch, you can choose either “Sustaining” (suitable for loops of sustained sounds such as strings or vocal) or “Slice” (suitable for loops of decay-type sounds such as drums). (Stereo samples are supported.) (See “Time Stretch” on page 347 of the Parameter Guide)
- Sometimes when looping a sample of pitched instruments such as strings or winds, the looped portion may play back in an unnatural way. By executing the Crossfade Loop function you can eliminate this problem so that the loop sounds right. (See “Crossfade Loop” on page 350 of the Parameter Guide)

### Loop settings

1. **Select the sample for which you wish to make loop settings.**

To select the sample, use the **Sample (Sample Select)** or **Index** parameters of P2: Loop Edit page or of the P0: Recording- Recording page.

⚠ If you use **Sample (Sample Select)** to select the sample, be aware that the assignment to the index will also change.

### Loop

2. **In the P2: Loop Edit page, use the “Loop” check box to turn loop playback on/off for the sample.**

Looping will be turned on if the box is checked.

This will operate between the addresses you specify in step 3.

Loop On: Start→End→Loop Start→End→ (Loop Start→End is repeated)

Loop Off: Start→End

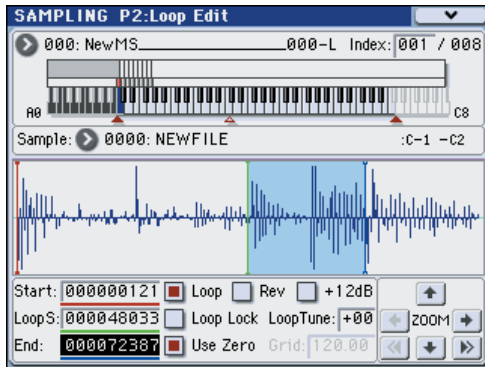

To play the sample, press the key to which the sample is assigned (the key range that is highlighted in “Keyboard & Index”).

A sample waveform that was sampled with “Sample Mode” set to Stereo will be displayed in two levels. The upper level is the L channel, and the lower level is the R channel.

**3. Specify the start address in “Start,” the loop start address in “Loop Start,” and the end address in “End.”**

Select **Start** (highlighted), and use the VALUE dial or other VALUE controllers to modify the value. The corresponding vertical line will move. Set **Loop Start** and **End** in the same way. In the example shown below, **Start** is set immediately before the first waveform, **Loop S (Loop Start)** is set immediately before the second waveform, and **End** is set as desired.

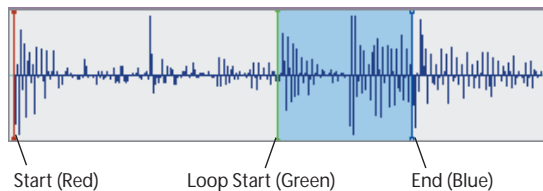

**ZOOM**

**4. By using the ZOOM button you can change the range that is displayed. When “Start” is highlighted, zoom will be performed from the start address.**

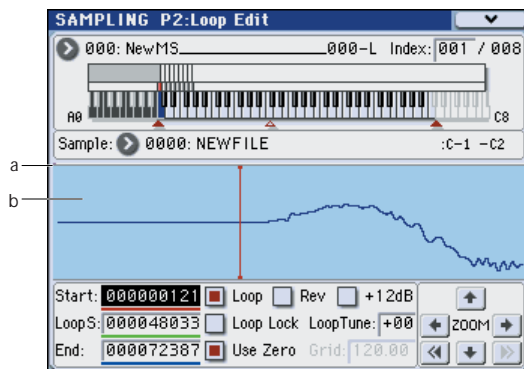

Area “a” indicates the region within the entire sample that is shown in area “b.” As you zoom-in on the time axis, this shows you where the zoomed region is located within the entire sample. Use the Zoom buttons to specify how area “b” will show a magnified

(zoom-in) or reduced (zoom-out) view of the waveform.

**Use Zero**

If the **Use Zero** check box is checked, only those addresses where the waveform data crosses the zero level will be found automatically when searching, and can be set. This lets you easily make address settings where noise is less likely to occur when looping.

**Truncate**

**5. If necessary, use the menu command “Truncate” to delete unwanted data that falls outside the start (or loop start) and end addresses.**

Select the Front & End radio button.

In this example, we will not change the settings of the **Save to No.** and **Overwrite** check boxes, so press the OK button to execute.

When you execute this operation, the truncated sample data will automatically be assigned to the index.

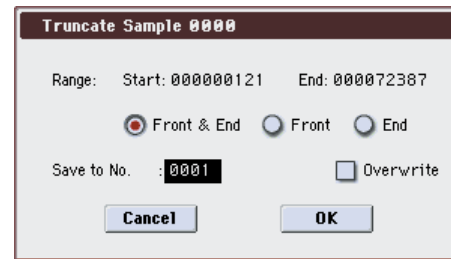

In the dialog boxes of some menu, there is a **Save to No.** setting that lets you specify the sample number to which the edited sample will be saved. At this time, a vacant sample number will be selected automatically, so you will change the setting only if you want to specify the save destination number. If you check **Overwrite** in the dialog box of the command, the data prior to editing will be deleted, and will be overwritten by the edited data. Normally, you will execute the Write operation without checking this, so that the unedited data is preserved. When you are completely finished with your editing, you can use the menu command **Delete Sample** to delete unneeded samples.

**Using the grid to make loop settings**

**Grid** overlays a grid on the waveform display to indicate the tempo BPM. This helps you make loop settings that match the tempo.

You can also view the grid in the P1: Sample Edit page, and use the grid to edit the waveform to match the tempo.

**1. Choose the Grid menu command.**

Select the On. Set **Resolution** as desired.

Press the OK button.

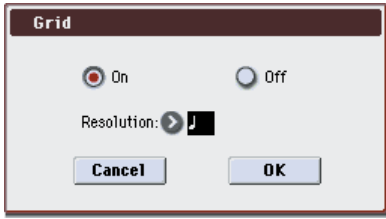

2. In P2: Loop Edit, use “Grid” to specify the tempo.

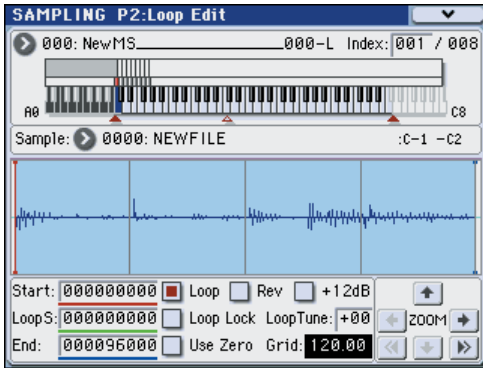

The grid is displayed according to the playback pitch at the base key (the key shown in blue for “Keyboard & Index”). You can select the base key by holding down the ENTER switch and playing a key.

Press the base key to play the sample, and press the TAP TEMPO switch at quarter-note intervals along with the phrase. This will enable Tap Tempo and specify the tempo.

3. Set the end address “End” so that it coincides with a grid line.

This will make the loop length match the BPM.

If looping is on, the grid is displayed beginning at Loop Start. If looping is off, the grid is displayed beginning at Start.

4. If you want to hide the grid display, select the off in the Grid menu command.

## Sample (waveform data) editing – P1: Sample Edit

Editing the waveform data.

In the P1: Sample Edit page you can do the following things.

- You can set the **Edit Range Start** and **Edit Range End** while watching the waveform. You can use functions such as Zoom In/Out, Use Zero, and Grid to edit the waveform efficiently.
- You can edit the sample waveform using a variety of commands such as cut, copy, mix, insert, normalize, volume ramp, and reverse. (See “Cut” on page 337 of the Parameter Guide)
- A Rate Convert function lets you lower the sampling frequency of the sample data in a range of 2/3 to 1/6, producing “down-sampled” effects. (See “Rate Convert” on page 340 of the Parameter Guide)
- The Link function (Link: with crossfade) lets you connect two samples into one. When doing so, you can apply a crossfade so that the sustained portion of the samples will change gradually to create a natural transition between the two samples. (See “Link” on page 341 of the Parameter Guide)

1. Select the sample that you wish to edit.

Use **Sample (Sample Select)** or **Index** in the P1: Sample Edit page or the P0: Recording, Recording page to select the sample.

⚠ If you use **Sample (Sample Select)** to select the sample, be aware that the index assignment will also change.

2. Access the P1: Sample Edit page.

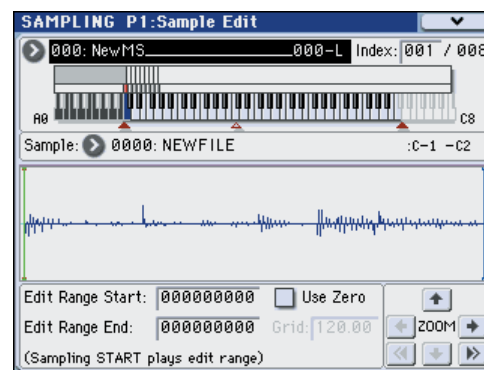

The waveform data of the currently selected sample will be displayed.

Sample waveforms that were recorded with a “Sample Mode” of Stereo will be shown in two lines. The upper line is the L channel waveform, and the lower line is the R channel waveform.

3. Use **Edit Range Start** and **Edit Range End** to specify the range that you wish to edit.

The selected range will be highlighted.

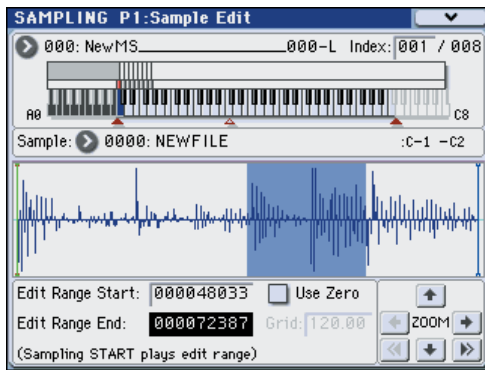

If you want to audition the selected region, press the SAMPLING START/STOP switch. The selected region will play at the pitch of the base key (the blue key in the keyboard display). You can specify the base key by holding down the ENTER switch and playing a note on the keyboard.

When you play a key to which the sample is assigned (the highlighted range of the keyboard displayed in “Keyboard & Index”), the sample will be played back according to its loop settings.

The procedure for using the ZOOM and Use Zero check boxes is the same as for P2: Loop Edit.

**4. From the list of menu, select the desired editing command. Make the appropriate settings in the dialog box, and press the OK button to execute.**

For details on the many sample editing features, please see “Sampling: Menu Command” on page 329 of the Parameter Guide.

## Multisample editing – P3: Multisample Edit

Editing a multisample is accomplished with a number of operations i.e. creating indexes for the multisample and assigning a sample to each index, editing operations such as deleting, copying, and inserting indexes, and detailed settings such as sample level and pitch for each index.

Multisample editing is performed in P3: Multisample. You can also do some basic edits in the P0: Recording–Recording page.

### Editing the indexes

To change the number or order of the indexes, use the Insert, Cut, Copy, and Create buttons.

**1. Access the P3: Multisample Edit page.**



**2. Use “Multisample (MS)” to select the multisample that you wish to edit.**

**3. Select the “Index.”**

You can also select an index by holding down the VALUE controller or ENTER switch and playing a note on the keyboard or pad.

**4. Press the buttons to modify the number or order of the indexes, and edit them.**

To delete the selected index, press the Cut button.

The Insert button is used in conjunction with the Cut and Copy buttons. The contents of the index that was Cut or Copied will be inserted.

The Create button has the same function as the Create button in P0: Recording (see “Creating multisample indexes and sampling – P0: Recording” on page 110).

### Modifying the settings of an index

**1. Make the settings described in steps 1–3 of “Editing the indexes.”**

**2. Set parameters for the selected index.**

- Use **Sample** to specify the sample for the selected index. You can also select a sample here.
- Use **OrigKey (Original Key)** to specify the original key of the sample.
- Changing the **Top Key** will change the upper limit of the zone. Simultaneously, the lower limit of the next-numbered index will also change. **Range**

indicates the zone determined by the **Top Key** setting.

- **Level** adjusts the playback level of the sample. You can use this to ensure that all samples in a multisample have a consistent level.
- If you check **Constant Pitch**, all notes in the index zone will sound the sample at its original pitch.
- “Pitch” adjusts the sample pitch for each index. You can use the **Pitch BPM Adjust** menu command to set the loop interval to the desired tempo. For details, please see “Pitch BPM Adjust” on page 351 of the Parameter Guide.

## Ripping – P5: Audio CD

The M3 allows you to “rip” digital audio data from an audio CD inserted in a USB A connected USB CD-R/RW drive (commercially available).

For details on the ripping procedure, please see “Destination” on page 351 of the Parameter Guide.

## Converting a multisample to a program

In pages P0: Recording–P4: Controllers, you can select and execute the **Convert MS To Program** menu command. When you execute this command, the settings of the currently selected multisample will be converted into a program. In Program mode you can make filter, amp and effect settings etc., and play the sample as a program. The resulting Program can be used in a Combination or Song.

1. Use “**Multisample Select (MS)**” to select the multisample that you want to convert to a program.
2. Choose “**Convert MS To Program**” to open the dialog box.

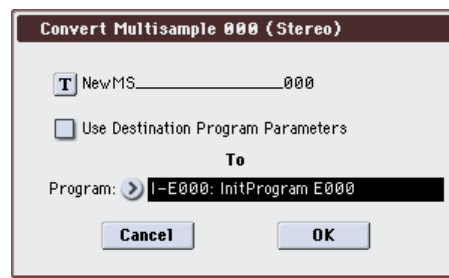

3. Press the text edit button to open the text edit dialog box, and input a new program name (up to 24 characters). By default, this will be the name of the multisample.
4. “Use Destination Program Parameters” unchecked:

When you execute, the multisample of the conversion-destination program will be replaced by the multisample you select here, and the other program parameters will be initialized. The program will reproduce the sound you heard in Sampling mode.

The program will be converted with an **Oscillator Mode** (Prog P1) of Single.

“Use Destination Program Parameters” checked:

When you execute, the multisample of the conversion-destination program will be replaced by the multisample you select here, but the other program parameters will not be initialized. Choose this if you want to use the parameter settings of an existing program.

- ▲ If you check **Use Destination Program Parameters**, please be aware of the following point.

The conversion-destination program’s **Oscillator Mode** must be Single. If this is not the case, a message of “Oscillator Mode conflicts” will appear when you attempt to execute. Please change the **Oscillator Mode** setting of the conversion-destination program.

5. Use the **To “Program”** field to specify the conversion-destination program.

We recommend that you use bank USER-E as the program bank for Sampling mode.

6. Press the **OK** button to execute.



**7. Press the MODE PROGRAM switch to enter Program mode, select the converted program, and try it out.**

*Note:* If you've created a multisample in Sampling mode and want to use it in a program without using the menu command **Convert MS to Program**, go to the Prog P2: OSC/Pitch- OSC1(2) Basic page and set the OSC1(2) Multisample **Bank** to RamM or RamS. With these settings, the multisample you created in Sampling mode will sound using the parameter settings of that program.

---

## Using a sample in a drum kit

Samples you create in Sampling mode can be used as drum kit instruments.

In the Global P5: Drum Kit- Sample Setup page, set the Drumsample **Bank** parameter to RamM or RamS.

---

## Saving multisamples and samples

If you want to keep the multisample and sample data you create, you must save your data onto either the USB storage device (commercially available).

In Sampling mode if you want to save only the multisamples and samples, you can execute the **Save Sample Data** menu command in the Media- Save page. If you have converted a multisample into a program, or if you are using multisamples or samples that you created in Combination or Sequencer mode or a drum kit you created in Sampling mode, we recommend that you save your data using **Save All** in order to ensure that it will be reproduced correctly the next time you load it.

In Program, Combination, or Sequencer modes, we also recommend that you use **Save All**.

 Unless you save to media (see page 142), any sample or multisample data you create will be lost when you turn off the power. For details, please see "Media that can be used with the M3" on page 223.

# Sampling in Program, Combination, and Sequencer modes

In addition to using Sampling mode, you can also sample both external audio sources and internal sounds in Program, Combination, and Sequencer modes.

You can also resample the performance in each mode while remaining in the internal digital domain. For instance, you can resample a performance that uses the M3's full range of features, including filters, effects, and KARMA. You can even sample a full, multitimbral sequence, played either from the internal sequencer or an external MIDI sequencer.

You can also sample the M3's performance together with audio from an external input source, or monitor the performance of the M3's KARMA function and sequencer etc. while you sample only the external audio from the input jacks.

In Sequencer mode, you can also sample an audio source that's being played along with the song, and the system will automatically create MIDI notes to play the new sample in sync with the song. You might use this to record a vocal or guitar part, for instance.

This is called In-Track Sampling.

## Resampling a phrase generated by the KARMA function

You can resample the sound of a program or combination being played by yourself or by the KARMA function.

In this example, we'll explain how to sample a KARMA-generated phrase in Program mode. You can sample in a similar way in Combination or Sequencer modes as well.

1. Press the **MODE PROG** switch to enter Program mode, and select the program that you want to resample.
2. Turn on the **KARMA** function (KARMA ON/OFF switch lit), play the keyboard, and verify that a phrase is generated.
3. Access the **P0: Play- Sampling/Audio In** page.

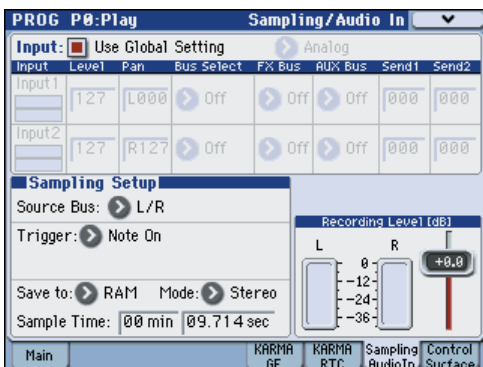

4. If "Use Global Setting" is checked, executing the menu command "Auto Sampling Setup" will edit the Input settings of Global mode. If this is not checked, the Input settings of each program will be edited. Since this is easy to verify here, uncheck this item.
5. Select the menu command "Auto Sampling Setup" to access the dialog box.

The various sampling-related parameters will be set automatically. You can use this as a guide when resampling the performance of a Program, Combination or Song, or when sampling an external audio source. You can also use this to initialize the settings.

### 6. Make the following settings.

**Resample Program Play:** On

Settings will be made for resampling the program's performance.

**Save to:** RAM

The resampled data will be written to RAM memory.

**Convert to Program:** On

**Program:** as desired

After resampling, the data will automatically be converted to the program number you specify in Program.

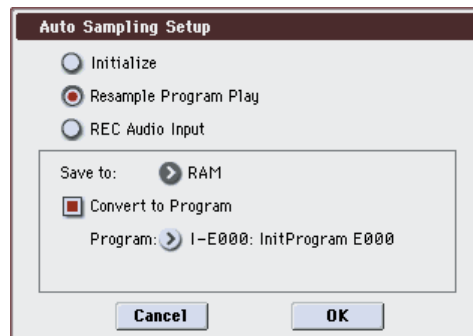

7. Press the **OK** button to execute the command.

Preparations for resampling have now been made.

*Note:* Let's take a look at the content of the settings.

**Input**

Each bus: Off

Turn all external inputs Off.

**RECORDING LEVEL**

**Recording Level:** 0.0

This is the default setting for resampling.

**Sampling Setup**

**Source Bus:** L/R

The sound sent to the L/R bus will be resampled.

**Trigger:** Note On

Sampling will start the moment you play the keyboard.

**Save to:** RAM

Sampling will occur to RAM memory.

**Mode:** Stereo

The sound of the internal L/R channels will be sampled in stereo.

### 8. Adjust the recording level.

Press the SAMPLING REC switch and use the **Recording Level** slider to adjust the level.

Play with the KARMA function turned on, and use the VALUE slider to adjust the **Recording Level** slider as high as possible without allowing the “CLIP !” indication to appear.

When you’ve finished making adjustments, press the SAMPLING REC switch.

Press the KARMA ON/OFF switch to turn the KARMA function off.

### 9. Sample.

Press the KARMA ON/OFF switch to turn it on.

Press the SAMPLING REC switch.

Press the SAMPLING START/STOP switch to put the M3 in record-ready mode.

Play the keyboard.

Recording will start the moment you play the keyboard.

While recording continues, all the sound you produce using the keyboard or controllers will be recorded.

Press the SAMPLING START/STOP switch to stop recording.

### 10. Listen to the sound you resampled.

Select the convert-destination program bank and number.

When you play the C2 key, you’ll hear the resampled sound.

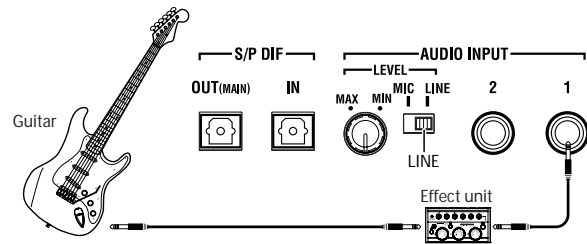

**!** If you connect a guitar with passive pickups (i.e., a guitar that does not contain a preamp), you will be unable to sample it at the correct level because of the impedance mismatch. Such guitars should be routed through a preamp or an effect unit.

### 5. Access the P0: Play– Sampling/Audio In page.

**6. If “Use Global Setting” is checked, executing the menu command “Auto Sampling Setup” will edit the Input settings of Global mode. If this is not checked, the Input settings of each program will be edited. Since this is easy to verify here, uncheck this item.**

**7. Select the menu command “Auto Sampling Setup” to access the dialog box.**

### 8. Make the following settings.

**REC Audio Input:** On

Make settings for sampling an external audio source while you monitor the performance of a program.

**Mono-L/Mono-R/Stereo:** Mono-L

If you’re using analog input, make settings so that the sound from Input 1 will be sampled to L-MONO.

**Save to:** RAM

The resampled data will be written to RAM memory.

**Convert to Program:** On

**Program:** as desired

After resampling, the data will automatically be converted to the program number you specify in **Program**.

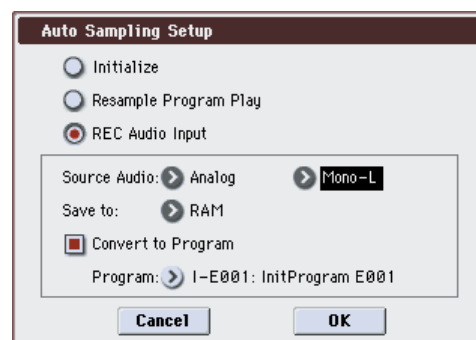

### 9. Press the OK button to execute the command.

Preparations for sampling have now been made.

*Note:* Let’s take a look at the content of the settings.

Analog INPUT1

**AUX Bus:** 1/2

Other Bus: Off

The input from AUDIO INPUT 1 will be sent to the AUX Bus 1/2.

**RECORDING LEVEL**

**Recording Level:** 0.0

This is the default setting for resampling.

Sampling Setup

**Source Bus:** L/R

## Sampling only an external guitar sound while listening to phrases generated by the KARMA function

Here we’ll explain how to sample just an external audio source while you listen to phrases generated by the M3’s KARMA function in Program mode.

Sampling can be performed in a similar way in Combination and Sequencer modes as well as in Program mode.

**1. Press the MODE PROG switch to enter Program mode, and select the program that you want to use for monitoring.**

**2. Turn the KARMA function on (KARMA ON/OFF switch lit), play the keyboard, and verify that the drum phrase plays.**

Turn LATCH on. Press the LATCH switch to make it light.

Also adjust the tempo “♪” as desired.

**3. Press the KARMA ON/OFF switch to turn off the KARMA function.**

**4. Connect your guitar to the rear panel AUDIO INPUT 1 jack.**

Press the AUDIO INPUT MIC/LINE switch select the LINE position, and set the LEVEL knob at about the center.

The sound sent to AUX Bus 1/2 will be sampled. The sound of the internal sound generator sent to the L/R bus will not be sampled.

**Trigger:** Sampling START SW

Press the SAMPLING REC switch to enter record-standby mode. Then press the SAMPLING START/STOP switch to start sampling.

**Save to:** RAM

The sample will be recorded to RAM memory.

**Mode:** L-Mono

The sound of the internal L channels will be sampled in mono.

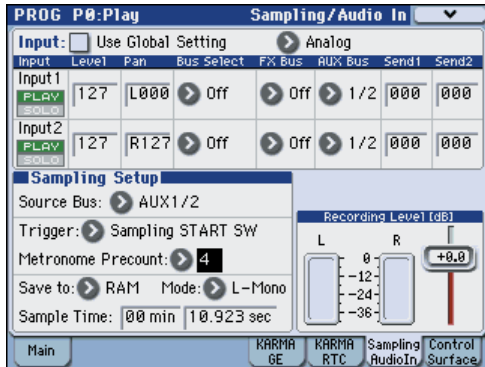

**10. Let's modify some of the settings.**

**Metronome Precount:** 4

When you press the SAMPLING REC switch to enter record-standby mode and then press the SAMPLING START/STOP switch to start sampling, a four-beat count will sound, and then recording will begin. (The metronome will not sound during recording.)

You may also wish to adjust the Input Pan.

**11. Play your guitar at the volume that you will be recording.**

If the display indicates "ADC OVERLOAD !" (ADC converter input overload), turn the rear panel LEVEL knob toward MIN to adjust the level appropriately.

The best audio quality will be obtained at the highest possible level that does not cause an overload; i.e., a level that is slightly below the point where "ADC OVERLOAD !" is displayed.

**12. Press the SAMPLING REC switch.**

Play your guitar, and the level meter will indicate the volume at which the guitar will be sampled.

Press the KARMA ON/OFF switch to turn it on, play the keyboard to start the drum phrase, and play your guitar while adjusting the final volume.

If the "CLIP !" indication appears, use the VALUE controller to lower the **Recording Level** slider (located in the right side of the display) below +0.0 to an appropriate level.

**13. When you have finished making adjustments, press the SAMPLING REC switch.**

Press the KARMA ON/OFF switch to turn off the KARMA function.

**14. Press the KARMA ON/OFF switch to turn it on, and then press the SAMPLING REC switch to enter record-ready mode.**

**15. Press the SAMPLING START/STOP switch to begin recording.**

**16. When you've finished recording, press the SAMPLING START/STOP switch to stop recording.**

**17. Press the KARMA ON/OFF switch to turn it off.**

**18. Listen to the sound that was sampled.**

Select the convert-destination program bank and number.

When you play the C2 key, you'll hear the sampled sound.

## Sampling a mix of the phrases generated by the KARMA function together with an external guitar sound

Here we'll explain how to sample a performance generated by the KARMA function along with the sound of an external guitar.

In this example, we will sample a phrase generated by the M3's KARMA function in Program mode together with the performance of a guitar connected to the AUDIO INPUT jack.

Sampling can be performed in a similar way in Combination and Sequencer modes as well as in Program mode.

1. **Press the MODE PROG switch to enter Program mode, and select the drum program that you want to resample.**
2. **Turn the KARMA function on (KARMA ON/OFF switch lit), play the keyboard, and verify that the drum phrase plays.**

Turn LATCH on. Press the LATCH switch to make it light.

Also adjust the tempo "♪" as desired.

3. **Press the KARMA ON/OFF switch to turn off the KARMA function.**
4. **Connect your guitar to the rear panel AUDIO INPUT 1 jack.**

Refer to step 4 of the procedure above. (See page 123)

5. **Access the P0: Play- Sampling/Audio In page.**
6. **Uncheck "Use Global Setting."**
7. **In this example, we'll make settings manually without using "Auto Sampling Setup."**

Since this sampling example is a combination of the two preceding examples, we'll need to make several changes to the settings created by **Auto Sampling Setup**.

Make the following settings.

Audio Input

**Use Global Setting:** Off

INPUT1

**Bus Select:** L/R

**Pan:** as desired

**Level:** 127

**AUX Bus:** Off

The input from AUDIO INPUT 1 will be sent to the L/R bus.

RECORDING LEVEL

**Recording Level:** 0.0

This is the default setting for resampling.

Sampling Setup

**Source Bus:** L/R

The sound sent to L/R bus will be sampled.

**Trigger:** Sampling START SW

Press the SAMPLING REC switch to enter record-standby mode. Then press the SAMPLING START/STOP switch to start sampling.

**Metronome Precount:** 4

There will be a four-beat countdown.

**Save to:** RAM

The sample will be recorded to RAM memory.

**Mode:** Stereo

The sound of the internal LR channels will be sampled in stereo.

8. **Adjust the volume of the guitar and the drum phrase that you'll be recording, and then sample the sound.**

Refer to steps 11–17 of the procedure above. (See page 124)

9. **Listen to the sound that was sampled.**

If you've been following along with the earlier examples, the convert-destination program bank and number are still specified. Select that program and play the C#2 note, and you'll hear the sampled sound.

If you're not using the Auto Sampling Setup **Convert to Program** option, audition the sound in Sampling mode.

In the Sampling P0: Recording- Recording page, use **Sample (Sample Select)** to assign the sample. To audition the sampled sound, play the key of the index you assigned.



## In-Track Sampling

In-Track Sampling creates note data at the appropriate timing when you sample an external audio source while playing back a song in the Sequencer mode. When you then play back the song, the sample will be triggered by this note data. In other words, this function plays back the sample at the same moment in the song at which you recorded it.

In this example, we'll show the sound of a guitar connected to the AUDIO INPUT 1 jack can be added to your song.

**1. Press the MODE SEQ switch to enter Sequencer mode.**

**2. Select the song to which you want to add the guitar sound.**

You can either create a song, or use Media mode to load a previously-created song.

**3. Connect your guitar to the rear panel AUDIO INPUT 1 jack. (See page 123)**

**4. Access the P0-1: Play/REC- Sampling/Audio In page.**

**5. The Input "Use Global Setting" off.**

**6. Choose the Auto Sampling Setup menu command.**

A dialog box will appear.

**7. Choose "In-Track Sampling."**



**8. Make the following settings for "In-Track Sampling."**

**Source Audio:** Analog

**Mono-L/Mono-R/Stereo:** Mono-L

If you're using analog input, make settings so that the sound from Input 1 is sampled to L-MONO.

**To:** as desired

The track you want to use for In-Track Sampling. MIDI note data to trigger the sample will be recorded in the track you selected.

**Program:** as desired

The convert-destination program number. When sampling is completed, a new multisample will be automatically created, converted to a program, and assigned as the program for the track.

**9. Press the OK button to execute the command.**

Preparations for In-Track Sampling are now completed.

Let's take a look at the settings that were made.

Audio Input  
INPUT1

Bus Select: Off

**Pan:** L000

**Level:** 127

**AUX Bus:** 1/2

The input from AUDIO INPUT 1 will be sent to AUX bus.

**RECORDING LEVEL**

**Recording Level:** 0.0

This is the default setting for sampling.

**Sampling Setup**

**Source Bus:** AUX 1/2

The sound sent to AUX 1/2 bus will be sampled.

**Trigger:** Sampling START SW

Press the SAMPLING REC switch to enter record-standby mode. Then press the SAMPLING START/STOP switch to start sampling.

**Save to:** RAM

The sample will be recorded to RAM memory.

**Mode:** L-Mono

The sound of the internal left channel will be sampled in mono.

**10. For this example, change the settings as follows.**

**Pan:** C64

**Trigger:** Threshold, **Threshold Level:** as desired

**Sample Time:** as desired

**11. Play your guitar at the volume that you will be recording.**

If the display indicates "ADC OVERLOAD !" (AD converter input overload), turn the rear panel LEVEL knob toward MIN to adjust the level appropriately.

For the best sound, adjust the level as high as possible without allowing the "ADC OVERLOAD !" indication to appear.

**12. Press the SAMPLING REC switch.**

When you play your guitar, the level meter will indicate the volume at which the guitar will be sampled.

If the display indicates "CLIP !," use the VALUE controllers to lower the **Recording Level** slider (in the right of the display) below +0.0 to an appropriate level.

**13. When you have finished making adjustments, press the SAMPLING REC switch.**

**14. Press the SAMPLING REC switch, and then the SAMPLING START/STOP switch to enter recording-standby mode.**

Press the LOCATE switch to reset the song playback location to the beginning of the song, and press the SEQUENCER START/STOP switch to play back.

Begin playing at the point where you want to record.

Sampling will begin when the **Threshold Level** volume is exceeded.

**15. At the point where you want to stop sampling, press the SEQUENCER START/STOP switch.**

Song playback and sampling will end.

Sampling will also stop if the specified **Sample Time** is reached.

**16. Press the LOCATE switch to return to the beginning of the song, and press the SEQUENCER START/STOP switch. Notice that the sampled audio is played back along with the song.**

For details on how the Compare function works for In-Track Sampling, please see “In-Track Sampling” on page 126.

## Resampling a song to create a WAVE file

Here we'll explain the procedure for resampling a song to create a stereo two-channel WAVE file on a USB storage device (such as a commercially available hard disk).

You can record a completed Song to a stereo WAVE file, and then burn that WAVE file to an audio CD using the USB CD-R/RW drive (commercially available). For details, please see “Creating audio CDs” on page 150.

1. Press the **MODE SEQ** switch to enter **Sequencer mode**.
2. Select the song from which you want to create a **WAVE file**.

Either create a song, or use Media mode to load a previously-created song.

- ⚠ A maximum of 80 minutes for either mono or stereo can be written to media in one sampling operation (mono: approximately 440 MB, stereo: approximately 879 MB).

3. Access the **Seq P0-1: Play/REC- Sampling/Audio In** page.
4. **Audio Input “Use Global Setting” off.**
5. Choose the **Auto Sampling Setup** menu command. A dialog box will appear.
6. Choose **“2ch Mix to Media.”**



7. Press the **OK** button to execute the command.

Preparations for WAVE resampling are now complete.

Analog, S/P DIF, (FireWire)

Input 1, 2

**Bus Select:** Off

**AUX Bus:** Off

Turn off all input from INPUT 1, 2 and S/P DIF L, R.

**RECORDING LEVEL**

**Recording Level:** 0.0

This is the default setting for resampling.

**Sampling Setup**

**Source Bus:** L/R

The sound sent to L/R bus will be sampled.

**Trigger:** Sequencer START SW

Press the **SAMPLING REC** switch and **START/STOP** switch to enter record-standby mode. Then press the **SEQUENCER START/STOP** switch to start recording.

**Save to:** MEDIA

The sample will be saved on the media you specified in **Select Directory**.

**Mode:** Stereo

The sound of the internal L/R channels will be sampled in stereo.

**8. Select the menu command Select Directory, and specify the destination to which the WAVE file will be written.**

Use **Media Select** and the Open and Up buttons to select the directory in which the WAVE file will be saved.

Press the text edit button to access the text edit dialog box, and input a filename (up to six characters).

Leave **Take No.** checked. The number at the right of **Take No.** will be input as the last two characters of the filename.

This number will increment each time you sample, ensuring that the filename will not be the same even if you sample repeatedly.

After you have made the settings, press the Done button to close the dialog box.

**9. Set Sample Time to the length that you want to sample.**

Set this to a length slightly greater than the length of the song.

**10. Set the recording level.**

- Press the SAMPLING REC switch.

*Note:* It will take between several seconds to nearly a minute from the moment you press the SAMPLING REC switch until the M3 enters standby mode (i.e., until the SAMPLING REC switch changes from blinking to lit). This time is required in order to allocate sufficient space on the media. You must never remove the media while in this state. Doing so may damage the media.

- Press the SEQUENCER START/STOP switch to play back the song, and adjust the sampling volume while you watch the level meters. The default setting is 0.0 dB. If the level is too low, use the VALUE controller to raise the level as high as possible without causing the "CLIP !" indicator to appear.
- When you finish making adjustments, press the SAMPLING REC switch.
- Press the SEQUENCER START/STOP switch to stop the song playback. Then press the LOCATE switch.

**11. Start sampling.**

- Press the SAMPLING REC switch and then the SAMPLING START/STOP switch to enter recording-standby mode.
- Press the SEQUENCER START/STOP switch to play back the song. Sampling will begin at the same time.

**12. When the song finishes playing back, press the SAMPLING START/STOP switch to stop sampling.**

**13. Use the menu command Select Directory to verify that the WAVE file was created. Select the file and press the SAMPLING START/STOP switch to listen to the sound that was sampled.**

# Settings for the entire M3 (Global mode)

## How Global mode is structured

In Global mode you can make overall settings that apply to the entire M3, such as master tuning, key transpose, effect global switch, global MIDI channel, and system clock.

In addition, you can create user drum kits, and scales, make settings for the damper pedal and assignable foot switches/pedals, and specify category names for programs, combinations and KARMA GE.

*Global mode page structure*

	Page	Main content
GLOBAL PARAMETERS	P0: Basic Setup	Basic overall settings, and audio input settings used when not in Sampling mode (for User Global Setting)
	P1: MIDI	MIDI settings for the M3. External Mode settings.
	P2: Controllers	Basic settings for the entire M3, and controller settings such as the pedals connected to the rear panel. CC# assignments for KARMA, X-Y, and Pad
	P3: Scales	Scale settings created by the user. You can specify 16 types of octave scale, and one full-range scale.
	P4: Category	Edit category names for programs and combinations.
DRUM KIT	P5: Drum Kit	Edit drum kits.

For details on how to access each mode and page, please see “Basic operations” on page 22.

⚠ The edits you perform in Global mode will be preserved until the power is turned off, but will not be preserved after the power is turned off unless you first save your settings. Two types of data are handled in Global mode: user drum kit settings (Global P5), and all other global settings (Global P0–4). Each of these can be written into their respective memory area. This data can also be saved to various types of media in Media mode. For details, please see “Writing Global settings, user Drum Kits” on page 141, “Saving to media (Media-Save)” on page 142.

⚠ The Compare function that lets you return to the state prior to your editing is not available in Global mode.

## Global settings

### Basic setup

In the Global P0: Basic Setup– Basic page you can make the following settings.

### Tuning to another instrument/ Transposing

**Master Tune** adjusts the overall pitch. Edit this setting when you are playing the M3 with other instruments, or when playing along with music on CD or tape. You can adjust the pitch in a range of  $\pm 50$  cents (one semitone = 100 cents). If this is at 0, middle A is tuned to 440 Hz.

**Key Transpose** shifts the pitch in semitone steps. Edit this setting when you want to transpose the sound of the entire M3. You can adjust the transposition in a range of  $\pm 1$  octave.

### Adjusting the way in which velocity or aftertouch will affect the volume or tone

You can adjust the way in which changes in velocity or aftertouch will affect the volume or tone. This lets you (for example) make the volume of the notes more consistent, even when they are played with varying dynamics.

Each curve has its own character, so you can select the curve that is appropriate for your own playing dynamics, playing style, and the effect that you wish to obtain (see “Velocity Curve” on page 356 of the Parameter Guide).

**Velocity Curve** selects the velocity curve, and **After Touch Curve** selects the aftertouch curve.

## Bypassing the effects

If the Effect Global SW “IFX 1–5 Off,” “MFX1&2 Off,” and “TFX Off” items are checked, the insert effects, master effect, will respectively be bypassed.

Insert effects, master effects, and total effect can be bypassed globally. This applies to the entire M3 regardless of the mode. For example, if you’ve connected the M3’s outputs to an external mixer and are using an external effect processor to apply reverb or chorus to the sound, you can turn off the M3’s master effects and total effect.

## Linking KARMA to Programs and Combinations

You can specify whether the KARMA settings written to a Program or Combination will also be selected when you select that program or combination, or whether the KARMA settings will not change when you switch the Program or Combination.

When the M3 is shipped from the factory, the former setting is selected. You can use the latter setting if you want to use the same KARMA settings to generate phrases and patterns while you select and try out different Programs and Combinations.

If the **Load KARMA Settings When Changing Program or Combination** boxes are selected, selecting a Program or Combination respectively will also select the KARMA settings that are written in that Program or Combination.

If you check **All KARMA/DT Off**, all KARMA functionality and the Drum Track function will be off. Even if the KARMA ON/OFF switch is on, the KARMA function will not operate.

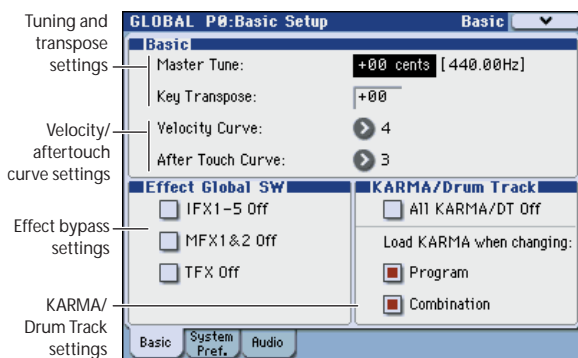

## Stopping the Drum Track function

If **All KARMA/DT Off** is checked, all KARMA functionality and the Drum Track function will be turned off. Even if the DRUM TRACK ON/OFF switch is on, the Drum Track function will not operate.

## System preference

In the Global P0: Basic Setup– System Preference page you can make the following settings.

## Settings when connecting multiple digital audio devices

If you’re connecting multiple digital audio devices via S/P DIF, set one device as the master and the remaining devices as slaves.

If you want the M3 to be the master, set **System Clock** to Internal. If you want the M3 to be a slave, set **System Clock** to S/P DIF.

## Recalling the last-selected mode and page at power-on

The state of M3 when the power is turned on will depend on the setting of **Power On Mode**.

If **Power On Mode** is set to Reset (factory setting), M3 will automatically select the Combination mode P0: Play.

If **Power On Mode** is set to Memorize, M3 will power on using the same mode and page that were selected when the power was turned off.

## Sounding a beep when you press the display

If **Beep Enable** is selected, a beep will sound when you press an object in the display. Uncheck this item if you don’t want a beep to sound.

## Protecting the memory

If one or more of the **Memory Protect** check boxes are checked, operations such as writing, loading, or song recording will be prohibited for the corresponding type of memory.

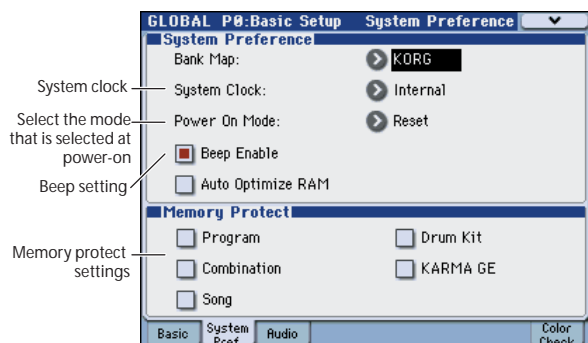



## Audio input settings

### Audio input settings used in common for Program, Combination, and Sequencer modes

In the Global P0: Basic Setup– Audio page you can make settings that will apply in modes other than Sampling mode; you can select the input source for analog/digital audio signals, and adjust the input level, bus, and master effect send levels.

To use these settings, check the **Use Global Setting** parameter in each mode.



## MIDI Basic/Routing

### MIDI-related settings for the entire M3

In the Global P1: MIDI– MIDI Basic page and the MIDI Routing page, you can make settings for the global MIDI channel, the local on/off setting, MIDI clock, MIDI routing, and MIDI filtering.

You can also use a menu command in this page to transmit MIDI exclusive data dumps. (See PG page 384)

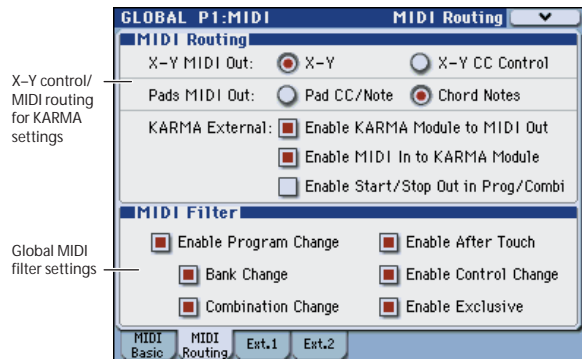
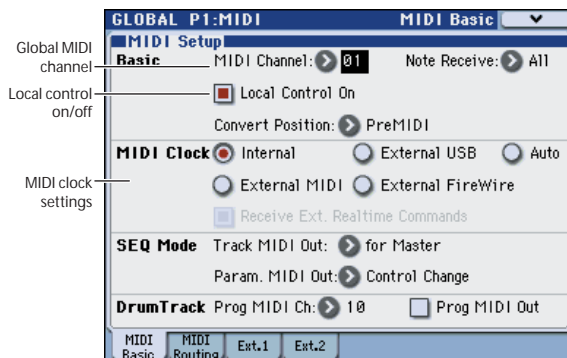

X-Y control/  
MIDI routing  
for KARMA  
settings

Global MIDI  
filter settings

## External control

The M3's external control capability lets you use the control surface switches 1–8, sliders 1–8, and pads 1–8 to control external MIDI devices. Each of these controllers can transmit a specified MIDI control change on the specified MIDI channel.

There are 128 sets of control assignments.

With the factory settings, the control sets contain preloaded data. For example, there are setups that let you control soft synthesizers such as the KORG Legacy Collection, and other setups that let you control the level and pan of a DAW (Digital Audio Workstation) program in realtime.

*Note:* See the “M3 External Setups” (PDF) for details on the control change (CC#) settings assigned by the preloaded external control templates and the application settings to which they correspond.

## Using external controls

*Note:* Before you continue, adjust your settings so that the M3 can send MIDI data to your computer application or MIDI device.

1. Press a **MODE PROG** switch (the LED will light).  
We've selected Program mode as an example here, but you are free to select Combination or Sequencer mode if you wish.
2. Press the **CONTROL ASSIGN EXTERNAL** switch (the LED will light).
3. Access the **Prog P0: Play– Control Surface** page.

This page shows and reflects the data of the control surface. It's a convenient place for you to adjust the sound, since you can view the parameter assignments and see the precise values.

*Note:* Control via the control surface is active regardless of the page shown in the display.



**4. Choose “Setup (Setup Select)”, and select the external control set that you want to use.**

The set list is shown in the lower portion of the page, showing the functions that are currently assigned to the switches and sliders.

**5. When you operate the control surface switches 1–8, sliders 1–8, and pads 1–8, MIDI control change (CC#) messages will be transmitted on the assigned MIDI channel.**

*Note:* The M3’s keyboard and other controllers will operate as usual.

**6. Use “Program Select” to switch programs.**

**7. Press the CONTROL ASSIGN EXTERNAL switch and operate the various controllers.**

You can use external control without losing the settings you’ve made.

Changing programs in Program mode or switching to Combination mode etc. will not affect the control set. This means you can select another sound on the M3 without changing the way you’re controlling an external MIDI device, or conversely you can change the way you’re controlling an external MIDI device without switching sounds on the M3.

## External control setups

You will use Global mode to create external control setups.

 The content that you edit in Global mode is preserved until you turn off the power, but will be lost when the power is turned off. To save your settings, execute **Write Global Setting** (or **Update Global Setup**).

**1. Press the MODE GLOBAL switch to enter Global mode.**

**2. Access the Global P1: MIDI– External Mode 1 page.**

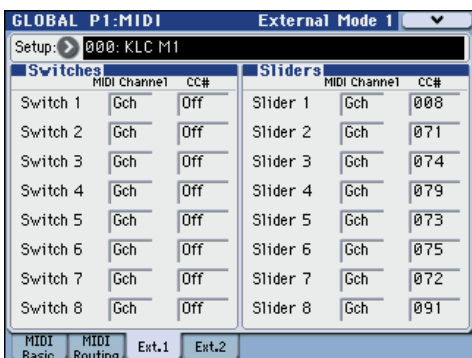

**3. Use “Setup (Setup Select)” to select the external control set that you want to edit.**

**4. In the External Mode 1 page you can make settings for switches 1–8 and sliders 1–8.**

**MIDI Channel** specifies the MIDI channel on which each switch or slider will transmit.

**CC#** specifies the MIDI control change that each slider or switch will transmit.

**5. Access the Global P1: MIDI– External Mode 2 page. Here you can make settings for pads 1–8.**

**MIDI Channel** specifies the MIDI channel on which each pad will transmit.

**Note/CC#** specifies the note or MIDI control change that each slider or switch will transmit.

**Fixed Velocity** specifies the velocity value that will be used if the front panel PAD MODE switch is set to FIXED VELOCITY (when the same velocity value will always be transmitted regardless of how strongly you strike the pads).

### Assigning a name

It’s a good idea to name any external control setups that you create so that you can remember its purpose.

Use the **Rename External Setup** utility to assign a name. For more details, please see “Editing names” on page 197.

## Pedal and other controller settings

In the Global P2: Controllers– Foot Controllers page you can make the following settings.

### Specifying the function of the Assignable Switch and Assignable Pedal

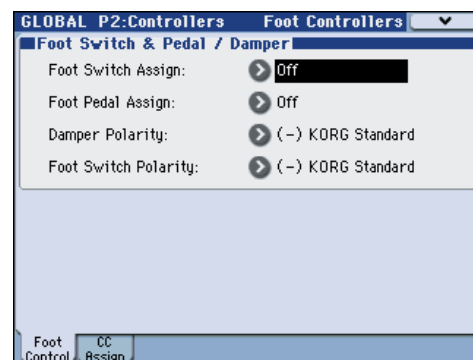

### Assignable Switch

**Foot Switch Assign** lets you assign a function to a footswitch, such as the optional Korg PS-1, connected to the rear-panel ASSIGNABLE SWITCH jack.

- This is set by “Foot Switch Assign.”

You can choose from the following functions:

- Alternate modulation source
- Effect dynamic modulation source

Switch portamento on/off  
 Control the sostenuto effect  
 Turn the soft pedal effect on/off  
 Turn the damper effect on/off  
 Select programs or combinations (up/down)  
 Value Inc/Dec  
 Start/stop the sequencer  
 Punch-in/out on the sequencer  
 Cue list repeat  
 Tap tempo  
 Control of KARMA function  
 Switch the drum track on/off  
 Switch X-Y mode or X-Y motion on/off  
 The functions of controllers such as the joystick or ribbon controller (See “Foot Switch Assign” on page 371 of the Parameter Guide)

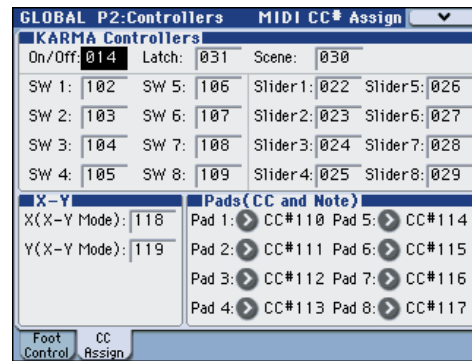

## Assignable Pedal

You can specify the function that will be performed by an assignable pedal (the optional XVP-10 Expression/Volume pedal or EXP-2 foot controller) connected to the ASSIGNABLE PEDAL jack.

- This is set by “Foot Pedal Assign.”  
 You can choose from the following functions.
  - Master volume
  - Alternate modulation source
  - Effect dynamic modulation source
  - Portamento pitch change speed
  - Volume (expression)
  - The pan following an insert effect
  - Pan
  - Volume
  - Send levels to the master effects
  - Duplicate the function of another controller, such as the joystick or ribbon (See “Foot Pedal Assign” on page 371 of the Parameter Guide)

*Note:* You can use this as a source for alternate modulation or effect dynamic modulation, and use it to control program parameters or effect parameters. In this case, set **Foot Switch Assign** to Foot SW (CC#82), and **Foot Pedal Assign** to Foot Pedal (CC#04).

## Assigning MIDI CC#s to KARMA, X-Y, and Pad controllers

In the Global P2: Controllers– MIDI CC# Assign page you can assign control change messages to the KARMA switches and sliders, pads 1–8, and the X-axis and Y-axis of X-Y control. Pads 1–8 can be assigned either control change messages or note numbers. You can assign control change messages or note numbers to pads 1–8.

Normally you will use the default settings. To restore the default settings, execute the **Reset Controller MIDI Assign** menu command and choose Default Setting.

## Creating user scales

### Creating an original scale, and assigning it to a Program

On the User Scale page, you can create your own original scales. These include sixteen different User Octave Scales, in which the pitch of each note of the octave is repeated for all octaves, and one User All Note Scale, in which the pitch of each of the 128 notes can be specified independently.

By adjusting the pitch of each key in the range of  $\pm 99$  cents, you can raise or lower it by approximately one semitone relative to the normal pitch.

The user scales you create here can be used by specifying the scale for a program, for each timbre of a combination, or for each track of a song.

You can choose these scales from the following pages.

Mode	Page
Program	P1– Key Zone/Scale: Scale
Combination	P2– Other T01–08, T09–16: Scale, Use Program's Scale
Sequencer	P3– Other T01–08, T09–16: Scale, Use Program's Scale

Here is how to set the scale type for each timbre in Sequencer mode.

- Create a user octave scale or a user all notes scale.  
 If you're creating a user octave scale, use **User Octave Scale Select** to select the scale you want to create.
- Select a key, and use the **VALUE** controllers to adjust the pitch. The range of  $\pm 99$  raises or lowers the pitch approximately one semitone above or below the standard pitch.

*Note:* You can also select a key by holding down the ENTER switch and playing the desired note on the keyboard.

*Note:* You can copy one of the preset scales and edit it to create an original scale. To do so, use the menu command **Copy Scale**.

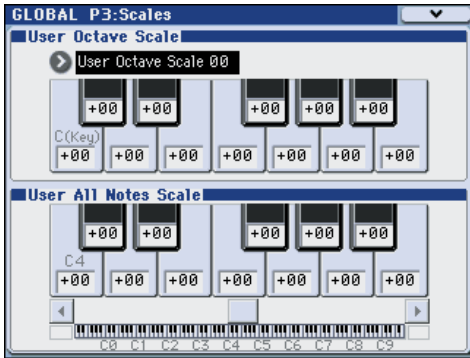

3. Press the MODE SEQ switch to enter Sequencer mode.
  4. Access the Seq P3: Track Param- Other T01-08 or T09-16 page.
  5. If you want the Track to use the scale saved with its individual Program, check the track's "Use Program's Scale" check box.
- Tracks that are not checked will use the scale specified by Scale Type.
6. Set "Type" to select the scale for the currently selected song.



## Setting Category Names

### Setting Category Names for Programs, Combinations, and KARMA GE

The Category Name pages let you assign names to the Program, Combination, and KARMA categories and sub-categories. (See "Global P4: Category" on page 374 of the Parameter Guide)

# Using Drum Kits

## Drum Kit Overview

### What's a Drum Kit?

A drum kit is a collection of drumsamples assigned to each key. Drum kits have the following features.

- A different sound will play for each note.
- A drumsample (one drum instrument) is assigned to each key. Drum samples are stored in the Rom bank, Ram bank, or in an EX \* bank.
- Samples you recorded on the M3 or loaded in Media mode can be selected from the RAM bank.
- On each note, you can use up to four Drumsamples, with velocity crossfades
- Each note has separate settings for the most important sound parameters, including volume, filter cutoff and resonance, envelope attack and decay, pitch, drive and low boost, and gain for each band of the Program EQ.  
For instance, you could combine high drive and low cutoff frequency to create a lo-fi effect on only a few sounds, while the rest of the sounds remained clear and pristine.
- Each note can be routed to different Insert Effects, or have separate FX Send amounts. For instance, you can send a snare sound through a dedicated compressor.

You can use Drum Kits only in Programs whose **Oscillator Mode** is set to **Drums**.

*Note:* The EX \* banks can be used if you've loaded optional EXB-USB-PCM series drumsamples.

### Drum Kit memory structure

The M3 has 153 Drum Kits, divided into Internal, User, and GM (General MIDI) groups as shown below. You can edit or write into any of the locations except for the GM bank, which cannot be erased.

*Drum Kit banks*

No. (Bank)	Contents
000(INT)...031(INT)	M3 preloaded drum kits
032(U-A)...047(U-A) 048(U-B)...63(U-B) 064(U-C)...79(U-C) 080(U-D)...95(U-D) 096(U-E)...111(U-E) 112(U-F)...127(U-F) 128(U-G)...143(U-G)	User drum kits
144(GM)...152(GM)	GM bank

The 9 Drum Kits in the GM bank are compatible with the GM2 sound map. The other Drum Kits may use different mappings, where appropriate.

## Drum Kit Programs and Oscillator Mode

The Program's **Oscillator Mode** setting, on the Prog P1: Basic/DT/Ctrls- Program Basic page, sets whether the Program is used to play Drum Kits or to play normal Multisamples (such as pianos, strings, etc.).

You'll see the results of this setting on the Prog P2: OSC/Pitch- OSC1 Basic page. If the **Oscillator Mode** is set to **Single** or **Double**, you can select up to four Multisamples for each Oscillator, with velocity switches or crossfades.

If the **Oscillator Mode** is set to **Drums**, you'll be able to select a single Drum Kit. There are still four levels of velocity switches and layers - but these are within the Drum Kit itself, and not stored or edited in the Program.



## Editing Drum Kits

### Before you start editing...

#### Drum Program selecting

Drum Kits are edited in Global mode. While you're in Global mode, you'll play the kit that you're editing as if you were playing it from within the Program, Combination, or Song which was selected before you entered Global mode.

So, before you enter Global mode, it's best to select a Program which is already set up for drums, with the appropriate EG settings, effects, and so on. Just use the Program Category select popup, and choose a drum Program. You'll probably want to start from Program mode, press the Category popup button to access the Category/Program Select menu, and choose a drum kit program from the Drums category.

#### OSC1/Basic Octave setting

In order for the note mappings to match the keyboard, the Oscillator's Octave setting needs to be +0 [8']. All Drum Kit Programs should have this setting already. If you're unsure, you can check this yourself:

1. Access the Prog P2: OSC/Pitch- OSC1 Basic page.
2. Check that the Oct (Octave) parameter (near the top of the page) is set to +0 [8'].

With a setting other than +0 [8'], the relationship between the keys and the Drum Kit sound map will be incorrect.

#### Make sure that Memory Protect is disabled

Before you start editing, go to the Global P0: Basic Setup- System Preference page, and look in the Memory Protect section. Make sure that **Drum Kit** is not checked—if so, you won't be able to make any edits.

#### Drum Kits may be used by more than one Program

When you edit a Drum Kit, all Programs that use that Drum Kit will be affected. To avoid changing the factory voicing, you may wish to copy Drum Kits to empty locations in the USER banks before editing.

#### Backing up a Drum Kit

Global mode does not have a Compare function that returns the edited result to the state prior to editing. Before you begin editing a user Drum Kit, it's a good idea to use **Copy Drum Kit** to copy that Drum Kit to a vacant number.

## Creating a Drum Kit

### Specifying the key to which you will assign a drumsample

1. Select the Program that you wish to use while editing the Drum Kit.

For details, please see "Drum Program selecting," above.

2. Press the MODE GLOBAL switch to enter Global mode.
3. Access the Global P5: Drum Kit- Sample Setup page.

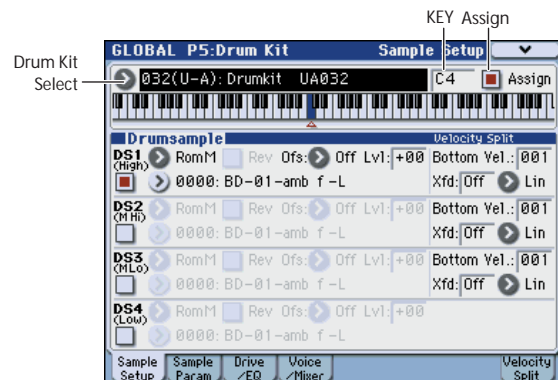

4. Use the Drum Kit parameter, at the top of the page, to select the Drum Kit that you wish to edit.

GM drum kits 144 (GM)–152 (GM) cannot be selected here. (It is not possible to edit or write a GM drum kit.) If you wish to modify the settings of one of the drum kits 144 (GM)–152 (GM), you can use "Copy Drum Kit" to copy it to 000 (INT)–143 (U-G), and then edit the copy.

5. Use the Key parameter to select the note that you wish to edit.

To select a key, you can use any of the standard VALUE controllers (the slider, dial, numeric keypad etc.). As a shortcut, you can also hold down the ENTER switch and play a note on the keyboard.

This Key selection applies to all five Drum Kit editing pages.

6. Use the Assign check box to specify whether the key will have its own settings, or use the same settings as the next higher note.

If **Assign** is checked, the key will have its own settings. This is the default.

If **Assign** is not checked, the key won't have its own settings. Instead, it will use the same settings as the next higher note—except that the drumsamples will be played at a lower pitch. The amount of pitch change depends on the **Pitch Slope** parameter, on the Prog P2: OSC/Pitch- OSC1 Pitch page.

Use this setting when you want only to change the pitch, such as with tom or cymbal sounds.

#### Creating a velocity crossfade

For this key, let's create a simple velocity crossfade between two stereo drumsamples.

1. On the left side of the page, make sure that DS1 and DS2 are turned On.

Just press the On/Off buttons to toggle them, if necessary.

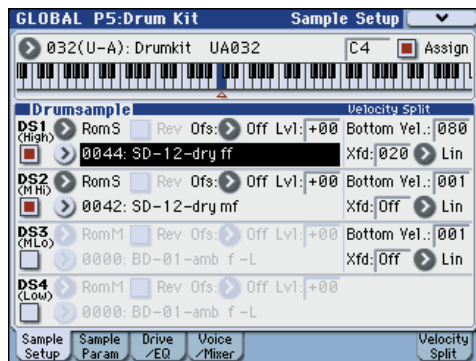

**2. Similarly, make sure that DS3 and DS4 are turned Off.**

When they are turned off, most of their parameters will be grayed out.

**3. Select RomS as the Bank for DS1 and DS2.**

There are three main types of Drumsample Banks: **Rom**, **Ram**, and **EX \***. For each type, you can also choose between looking at mono and stereo Drumsamples. For example in the case of Rom, RomM selects mono drumsamples, and RomS selects stereo drumsamples. Stereo drumsamples require twice as many voices as mono drumsamples. Note that stereo Drumsamples will require twice as many voices as mono Drumsamples.

**Rom** Drumsamples are the built-in “factory” sounds, and are always available. These are organized by category, such as bass drums, snares, hats, etc.

**Ram** Drumsamples include AKAI, AIFF, WAV or SoundFont 2.0 files loaded from media, and samples created in Sampling mode.

**EX \*** Drumsample banks are EX-USB-PCM expansion sets created especially for the M3. Each has its own unique number; for instance, the EX, and the EX-USB-PCM01 is EX1. Only the currently loaded EX \* banks will appear on this menu.

**4. Press the Drumsample popup for DS1.**

This brings up a list of Drumsamples, organized by category. Use the tabs at the left of the display to browse through the different categories.

For a list of the Drumsample names, please see the Voice Name List.

**5. Select a Drumsample by touching its name in the list.**

**6. Press the OK button to confirm your selection.**

**7. Do the same for DS2.**

Now that you’ve assigned Drumsamples to DS1 and DS2, let’s set up the velocity ranges and crossfades.

**8. Access the P5: Drum Kit– Velocity Split page.**

The following settings can also be made from the Sample Setup page, but the graphic in the right side of this page provides a visual indication of the settings.

**9. Set DS2’s Bottom Velocity to 001, and its Xfade Range to Off.**

**10. Set DS1’s Bottom Velocity to 80.**

Now, DS2 will sound when you play softly, at velocities of 79 or less—and DS1 will sound when you play harder, with velocities of 80 or more.

**11. Next, set DS1’s Xfade Range to 20, and its Curve to Linear.**

Notice that the graphic now shows the two ranges tapering into one another. Between 80 and 100, DS2 will fade out, and DS1 will fade in, creating a gradual velocity transition instead of a hard split.

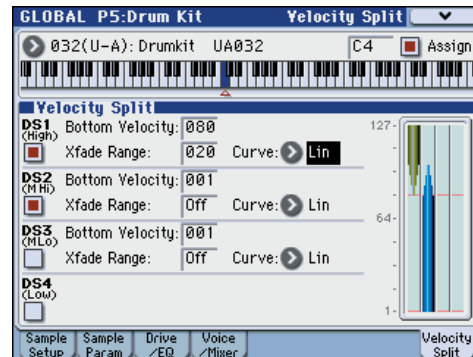

**Fine-tuning the sound of each sample**

**1. If you like, adjust the Levels for the two Drumsamples.**

This can be very useful in creating a smooth velocity split or crossfade.

**2. As necessary, specify the tuning, EG parameters, and filter.**

Access the P5: Drum Kit– Sample Parameter page.

Adjust **Tune**, **Attack (Amp EG Attack)**, **Decay (Amp EG Decay)**, **Cutoff** and **Resonance** for each drumsample.

**3. You can also edit the drive, boost, and EQ for each drumsample.**

Access the P5: Drum Kit– Drive/EQ page.

Adjust **Drive**, **Low Boost**, and **3 Band EQ Gain [dB]** for each drumsample.

For details, please see “5–2: Sample Parameters” on page 378 of the Parameter Guide.

**4. Repeat “Specifying the key to which you will assign a drumsample,” on page 136 to set up each key of the Drum Kit.**

**5. You can also copy settings from one key to another, using the Copy Key Setup menu command.**

**Using Exclusive Groups**

**1. Access the P5: Drum Kit– Voice/Mixer page.**

**2. Use the Exclusive Groups to make one drum sound cut off another drum sound - such as closed and open hi-hats.**

For example, let’s say that you’ve assigned an open hi-hat and a closed hi-hat to the same exclusive group:

- Play the open hi-hat sound.
- While it’s still ringing, play the closed hi-hat.
- The open hi-hat sound will be cut off—simulating the action of a physical hi-hat.

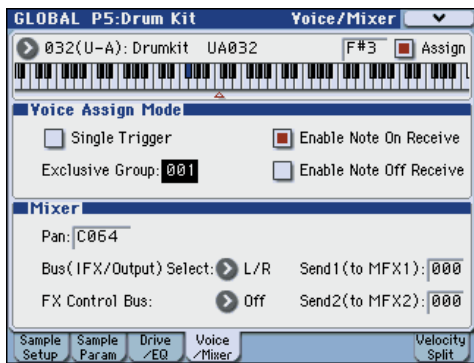

## Using Hold

The Program **Hold** parameter can be especially useful for drum programs, since it lets the samples ring out naturally regardless of how long you hold down the note. The way that this works depends on settings in both the Program and the Drum Kit, as described below.

To enable **Hold**:

1. Access the **Prog P1: Basic/DT/Ctrl- Key Zone/ Scale** page.
2. Under **Key Zone**, make sure that the **Hold** check-box is checked.

Once you've turned on **Hold** for the Program, the function is controlled on a note-by-note basis according to settings within the Drum Kit.

3. Access the **Global P5: Drum Kit- Voice/Mixer** page.
4. For each key, set the **Enable Note Off Receive** parameter as desired.

If this parameter is unchecked, the key will be held.

If it is checked, the key will not be held.

If you turn off **Hold** in the Program, no keys will be held - regardless of their **Enable Note Off Receive** setting.

## Controlling effects for each key

Drum Kits have their own, built-in mixers. For each key, you can control the Insert Effects bussing, Master Effects sends, and pan.

To use separate bus settings for each key:

1. Access the **Prog P8: IFX- Routing** page.
2. Make sure that the **Use DKit Setting** check-box is checked.

When **Use DKit Setting** is on, the Program will use the Bus Select and Effects Send settings for each key of the Drum Kit.

When **Use DKit Setting** is off, the Program will ignore the Drum Kit's Bus Select and Effects Send settings.

3. Access the **Global P5: Drum Kit- Voice/Mixer** page.
4. Use the **Bus (IFX/Output) Select** parameter to send drum sounds through their own Insert effects, or to the individual outputs.

If you like, you can send each note to its own Insert effect, or to the individual audio outputs, in addition to the main L/R outputs.

For example, you might send all snare sounds to **IFX1**, all kick sounds to **IFX2**, and the remaining sounds to **L/R**.

*Tip:* In most preloaded drumkits, the drum instruments have the same **Bus (IFX/Output) Select** settings according to their type, as follows.

Snares → IFX1

Kicks → IFX2

Other → IFX3

5. Use **Send1 (to MFX1)** and **Send2 (to MFX2)** to set the send levels to the master effects.

## Controlling pan for each key

To use separate pan settings for each key:

1. Access the **Prog P4: Amp/EQ- Amp1/Driver1** page.
2. Under **Pan**, make sure that the **Use DKit Setting** check-box is checked.

When **Use DKit Setting** is on, the Program will use the pan settings for each key of the Drum Kit.

3. Access the **Global P5: Drum Kit- Voice/Mixer** page.
4. Use "Pan" to specify the panning for each key.

## Saving Drum Kits

Once you've spent all this time editing, you'll want to save your work.

- ▲ The contents of your editing in Global mode are preserved as long as the power is on, but will be lost when you turn off the power. If you want to keep your edits, you must execute **Write Drum Kits** (or "Update Drum Kits"). This will save all drum kits.

# Loading & saving data, and creating CDs

## Saving data

### Types of data that can be saved

You can save the various types of data in the M3 by writing it to internal memory, by saving it to a USB storage device (commercially available hard disk, removable disk, CD-R/RW, etc.), or by sending it as a MIDI data dump.

### Writing to internal memory

The following types of data can be written into the internal memory.

- **Program**  
Programs 000–127 in banks INT-A...F, USER-A...G (INT-F is available only if the optional EXB-RADIUS is installed)
- **Combination**  
Combinations 000–127 in banks INT-A...G, USER-A...G
- **Global settings**  
(Global P0: Basic Setup–P4: Category)
- **User drum kits**  
000(INT)...143(U-G)
- **User Drum Track patterns**  
U000...U999  
(See page 185)
- **User template songs U00–U15**  
Song settings such as the song name and tempo, track settings (see PG page 192), KARMA, and effect settings can be saved (written) to internal memory. However, the musical data for song tracks and patterns are not saved to internal memory. Furthermore, settings that govern how the musical data is played back such as **Meter**, **Metronome**, **PLAY/MUTE**, **Track Play Loop** (including Start/End measure), and RPPR settings will not be saved either. Use the Sequencer mode menu command **Save Template Song** to write this data; for details, please see “Save Template Song (Save as User Template Song)” on page 272 of the Parameter Guide.
- **Effect presets**  
For each effect, you can write parameter settings into internal memory by using the menu command **Write FX Preset**.

 RAM Multisamples and Samples must be saved to and loaded from media; they cannot be written into internal memory.

This means that if you turn the power off and then on once again, but do not re-load the necessary RAM Multisamples or Samples, any data that uses such multisamples or samples will not sound as

intended. This can include Combinations, Programs, Drum Kits, and Multisamples.

 Data that you edit in Sequencer or Sampling mode can only be saved to media; it cannot be saved in internal memory.

### About preloaded data and preset data

“Preloaded data” refers to the data that is loaded in the M3 when it is shipped from the factory. You are free to rewrite this data, and with the exception of the demo songs, the data will be written to the location listed in “Writing to internal memory.” This data is stored in the M3’s system area.

You can reload this data into internal memory by using the Global mode menu command **Load Preload/Demo Data**.

Preset data is data that cannot be rewritten by the Write operation. This includes the following data.

- GM program banks G, g(1)–g(9), g(d)
- Template drum kits 144(GM)–152(GM)
- Preset template songs P00–P15
- Preset patterns P000–P522

### Saving to media, CDs, and USB media

The following data can be saved to various types of media.

- **.PCG file:**  
Programs, Combinations, Drum kits, Global settings, RADIUS formant motions (if the optional EXB-RADIUS is installed), and user Drum Track patterns (The data that was checked in the check boxes of the Save dialog box will be saved.)
- **.SNG file:**  
Song and cue list.
- **.KSC, .KMP, .KSF files:**  
Lists of sample and multisamples (.KSC file), multisamples (.KMP file), samples (.KSF file).
- **.KCD file:**  
These are track lists for audio CD tracks.
- **.EXL file:**  
System exclusive data from an external device that was saved on the M3 (This allows the M3 to be used as a data filer.)
- **.MID file:**  
Saves a Sequencer mode song in Standard MIDI File (SMF) format.
- **.WAV and .AIF files:**  
A sample you recorded can be exported (written) as a WAVE file or AIFF file.

## MIDI data dump

You can transmit the M3's data to an external MIDI data filer device, and save the data on that external device.

The following types of data can be transmitted as a MIDI data dump and saved on an external data filer or other device.

- Programs, combinations, drum kits, and global settings
- Song and cue list
- User drum kit patterns
- RADIUS formant motions (if the optional EXB-RADIUS is installed)

For details, please see "Dump:" on page 384 of the Parameter Guide.

## Writing to internal memory

### Writing a Program or Combination

The Program and Combination settings you've edited in the various editing pages can be saved to internal memory. This action is referred to as "writing a program" or "writing a Combination." If you want your edited data to be preserved after the power is turned off, you must write it.

There are two ways to write a Program or Combination.

- ⚠ Before you write data into memory, you must turn off the memory protect setting in Global mode. (See "Memory protect" on page 142)
- ⚠ A combination does not contain the actual program data for each timbre, but simply remembers the number of the program used by each timbre. If you edit a program that is used by a combination, or exchange it with a different program number, the sound of the combination will also change.

### Using the Write menu command

1. Verify that the program or combination you want to save is selected.
2. Select the menu command "Write Program" or "Write Combination."

The **Write Program** or **Write Combination** dialog box will appear.

*Note:* You can also access the same dialog box by holding down the ENTER switch and pressing the 0 switch. (See "Shortcuts" on page 200)



*This screenshot is for Program mode*

3. Check the program/combination name displayed in the upper line (the writing source).
4. If you wish to change the name of the program/combination, press the text edit button.

The text dialog box will appear. Enter the name of the program/combination. See "Editing names" on page 197.

After you have entered the name, press the OK button to return to the Write Program/Write Combination dialog box.

5. In "Category," specify the category of the Program/Combination.
6. Select a "Sub Category" as well.

For combinations, the category and sub-category you specify here can be selected in the following pages.

Prog P0: Play  
"Category"

Combi P0: Play- Program T01-08, 09-16  
"Category"

Seq P0-1: Play/REC- Program T01-08, 09-16  
"Category"

For Programs, the category/sub-category you specify here can be selected in the following pages.

Combi P0: Play- Program T01-08, 09-16  
"Category"

7. Use "To" to specify the bank and number of the writing destination program/combination.

Use the VALUE controllers or the BANK switches to make your selection.

8. To execute the Write operation, press the OK button. To cancel without executing press the Cancel button.

When you press the OK button, the display will ask "Are you sure?" When you press the OK button once again, the data will be written.

The ENTER switch corresponds to the OK button, and the EXIT switch corresponds to the Cancel button. You can execute these operations by pressing the appropriate switch.

### Using the (SEQUENCER) REC/WRITE switch to write

This method can only be used to write the selected program/combination number.

1. Press the SEQUENCER REC/WRITE switch.

The following **Update Program/Update Combination** dialog box will appear.



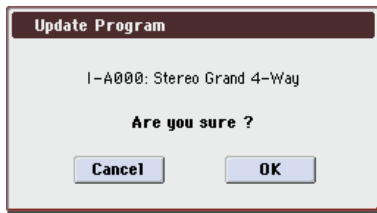

This screenshot is for Program mode

## 2. To write the data, press the OK button. To cancel without writing, press the Cancel button.

The ENTER switch corresponds to the OK button, and the EXIT switch corresponds to the Cancel button. You can execute these operations by pressing the appropriate switch.

## Writing while X-Y MODE is on

You can't perform operations in the display while X-Y MODE is on. If you need to write data while X-Y MODE is on, you must use the method described above in "Using the (SEQUENCER) REC/WRITE switch to write."

- Press the SEQUENCER REC/WRITE switch to access the dialog box, and then press the ENTER switch.

## About the Tone Adjust settings that are saved

There are three types of Tone Adjust parameters, as listed below. The way in which settings are written will depend on the type.

- **Absolute:** This type of Tone Adjust parameter controls a single program parameter. The Program parameter and the Tone Adjust parameter reflect each other exactly. If you edit one, the other parameter will reflect the identical change. This type of Tone Adjust parameter "absolutely" controls the program parameter itself.
- **Relative:** This type of Tone Adjust parameter controls two or more program parameters simultaneously. For example, "Filter/Amp EG Attack Time" controls a total of six program parameters. The value of a relative parameter indicates the amount of change that is applied to the value of each program parameter it's affecting. When a relative parameter is at zero (i.e., when its slider is in the center position), the program parameters it controls will function according to their original settings. Raising or lowering the value of a relative parameter will indirectly raise or lower the value of these program parameters.
- **Meta:** This type of Tone Adjust parameter affects other Tone Adjust parameters. It does not affect program parameters directly.

If you've adjusted an absolute or a relative Tone Adjust parameter, the result of your adjustment will be written as follows.

### Program mode:

- The settings of relative-type Tone Adjust parameters are automatically applied to the program parameters when you write the program. The Tone Adjust values will be reset to zero.

- The settings of absolute-type Tone Adjust parameters are written "as themselves" (i.e., as the settings of those Tone Adjust parameters).

### Combination mode:

- The settings of both relative-type and absolute-type Tone Adjust parameters are written and preserved as the Tone Adjust settings for each timbre.

For details, please see "Tone Adjust" on page 19, page 135 of the Parameter Guide.

## About the Program and Combination edit buffer

When you select a program in Prog P0: Play or a combination in Combi P0: Play, the program or combination data is called into the M3's edit buffer.

When you then use the various Program or Combination pages or each pages to edit the parameters, your changes will affect the data in the edit buffer.

If you wish to save this modified data into internal memory, you must perform the Write operation.

When you perform the Write operation, the data in the edit buffer is written to the specified program or combination number of the specified bank.

If you select another program or combination, without writing, the data of the newly selected program or combination will be called into the edit buffer, and your changes will be lost.

*Note:* When you press the COMPARE switch in Program mode, or Combination mode, the data from memory (i.e., the contents that were written into memory) will be temporarily called into the edit buffer. This allows you to compare the settings you are editing with the original un-edited settings.

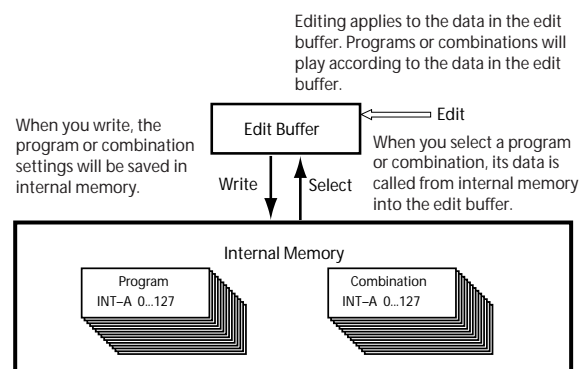

## Writing Global settings, user Drum Kits

The settings you edit in Global mode can be written into internal memory. This is done using the operations Write Global Setting, and Write User Drum Kits. If you wish to use these edited settings after you turn the power off, be sure to write the data first.

There are two ways to write global settings, user Drum Kits.

### Using a menu command to write

1. To write global settings (the various settings in Global P0–P4), press the menu command “Write Global Setting” in Global P0–P4.

Note: Alternatively, you can access the same dialog box by holding down the ENTER switch and pressing the 0 switch. (See “Shortcuts” on page 200)

The Write Global Setting dialog box will appear.



To write the Drum Kits (the settings of Global P0–P4), choose the menu command Write Drum Kits in Global P5.

The Write Drum Kits dialog box will appear.



2. To write the data, press the OK button. If you decide not to write, press the Cancel button.

When you press the OK button, the display will ask “Are you sure?” Press the OK button once again to write the data.

### Using the (SEQUENCER) REC/WRITE switch to write

1. In the following pages of Global mode, press the SEQUENCER REC/WRITE switch.

One of the following dialog boxes will appear according to the page.

P0–P4: Update Global Setting  
 P5: Update Drum Kits

2. To write the data, press the OK button. If you decide not to write, press the Cancel button.

### Memory in Global mode

When the power is turned on, the Global mode data is called from internal memory into the Global mode memory area. Then when you modify the parameters in Global mode, the data in the memory area will be modified. If you wish to save this modified data in internal memory, you must Write it.

When you write this data, the data in the memory area is written into the global settings.

If you turn off the power without writing, the modified data in the memory area will be lost.

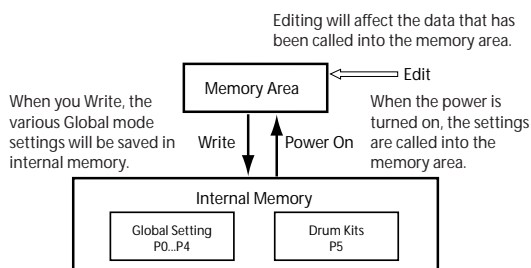

### Memory protect

To prevent Programs, Combinations, Songs, Drum Kits, and KARMA GE from being overwritten accidentally, the M3 provides a Memory Protect setting that prohibits writing to memory.

Before you save edited data or load data from media, use the following procedure to turn the memory protect off (uncheck the appropriate check box).

You must also turn memory protect off before loading the above data from media or via a MIDI data dump, or before recording in Sequencer mode.

1. Press the MODE GLOBAL switch to enter Global mode.
2. Access the Global P0: Basic Setup– Basic page.

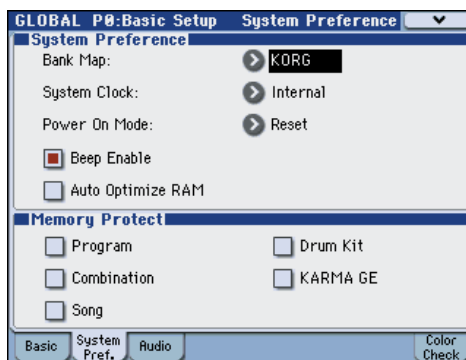

3. Press the “Memory Protect” check box for the type of data you wish to write to internal memory, so that the box is unchecked.

### Saving to media (Media–Save)

For details on the data that can be saved on storage media. (See “Types of data that can be saved” on page 139)

⚠ Song data in the M3’s Sequencer mode, as well as multisamples and samples cannot be written into internal memory. This data will disappear when the power is turned off. In order to keep this data, you must write it to the USB storage device (commercially available hard disk, removable disk). When you’ve come up with settings you like, it’s a good idea to save them, so that even if you subsequently edit those settings, you’ll always be able to reload the previous settings if desired.

### Types of media you can use

#### USB storage device

- **Hard disks**
- **Removable disks**  
 Hard disks and removable disks in MS-DOS format FAT16 or FAT32 are supported.

#### Capacity recognized:

FAT32: up to 2 terabytes = 2,000 Gigabytes (GB)  
 FAT16: up to 4 GB

- **CD-R/RW**  
 UDF format is supported. UDF format CD-R/RW discs can be written and read. (See “CD-R/RW

disks on the M3” on page 634)

Recording/playback of CD-DA (audio) data and reading of ISO9660 (level 1) format is also supported.

- **Floppy disks**

MS-DOS format 3.5 inch 2HD and 2DD floppy disks can be used. The formatted capacity of the floppy disks will be 1.44 MB (18 sectors/track) for 2HD, and 720 KB (9 sectors/track) for 2DD.

For details on connecting devices to the USB A connectors, please see page 33.

⚠ These types of media are not included. You will need to purchase them separately. (See page 223)

## Media setup

This section explains how to make the M3 recognize media so that data can be saved on it.

### Setup for using a USB storage device

1. Use a USB cable to connect the USB port of your USB storage device (commercially available hard disk, removable disk, CD-R/RW) to the USB A connector of the M3.

*Note:* The M3’s USB A connectors support hot-plugging; you can connect or disconnect the USB cable while the power is on. However in order to do so, your USB storage device must also support hot-plugging.

2. Turn on the power of the M3.
3. Turn on the power of your USB storage device, and use a USB cable to connect the USB port of your USB storage device to the USB A connector of the M3.

*Note:* The above step assumes that your USB device supports hot-plugging. If you are using a device that does not support hot-plugging, connect it with the power turned off. Then turn on the power.

4. While the M3 is accessing the USB device, do not connect another USB device or disconnect the connected device. Doing so may damage your data.
4. Press the MODE MEDIA switch to enter Media mode.
5. Press the Media Info tab, and then execute the menu command “Scan USB device.”
6. Use Media Select to select your media.

If you are using a removable disk, insert the media. After you exchange media in your USB device, press the display to make the M3 detect the media. When the media has been detected, information about the media will appear on the display.

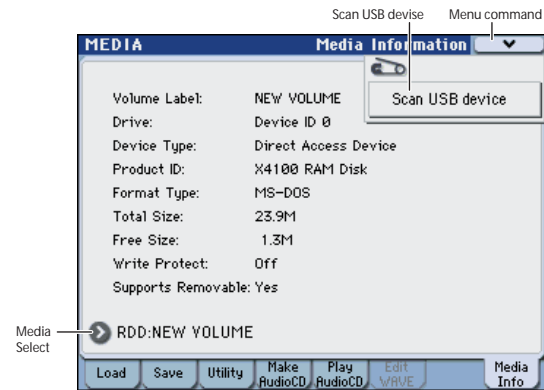

7. If the media needs to be formatted, execute the Format operation.

Media requiring formatting is indicated as Unformatted in **Media Select**. For details, please see “Formatting media” on page 148.

## How to save data

As an example here, we’ll execute **Save All** to save the .PCG, .SNG, .KSC, .KMP, and .KSF files.

“Save All” saves all internal memory Programs, Combinations, Drum Kits, Global settings, RADIAS Formant Motions (if the optional EXB-RADIAS is installed), and drum track user patterns to media as a .PCG file. It also saves songs and cue lists as a .SNG file, and multisamples and samples created in Sampling mode as a .KSC file.

This method is available only if the current directory is a DOS directory.

⚠ If you save this data to low-capacity media, you may need more than one media.

1. Prepare the media on which you want to save the data. (See “Media setup” on page 143)
2. Press the MODE MEDIA switch to enter Media mode.
3. Access the Media-Save page. Press the Save tab.
4. Press Media Select to select the save-destination drive.
5. If the media contains directories, select the directory in which you want to save the data.

Press the Open button to move to a lower level, or press the Up button to move to an upper level.

*Note:* If you are saving data on high-capacity media, we recommend that you create directories to organize the media into sections.

To create a new directory, move to the level at which you want to create the directory, and execute the Utility menu command **Create Directory**.

6. Press the menu button to access the menu, and press **Save All**.

A dialog box will appear. The contents, settings, and operations for the dialog box will depend on the type of data that you are saving.

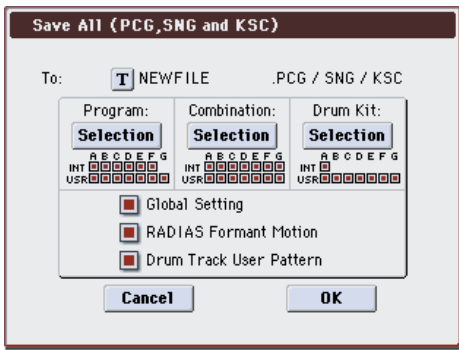

7. Press the text edit button and input a filename for the file you want to save. (See page 197)
8. Press each Selection button to access the dialog box, and use the check boxes to uncheck any items that you do not need to save.

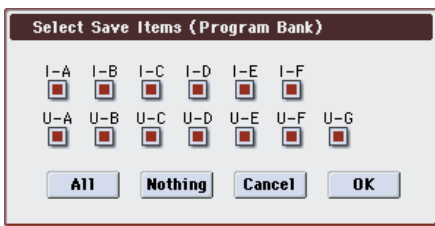

In order to accurately reproduce the data you created, we recommend that you check all of the boxes.

When you've finished making settings, press the OK button to close the dialog box.

**9. Press the OK button to execute the Save operation.**

- If the data fits on one volume of media  
The data will be saved on the specified media, and you will return to the Save page.
- If the data does not fit on one volume of media  
The "No space available on medium" dialog box will appear.

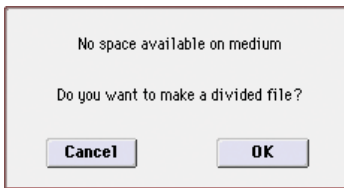

Press the OK button and the file will be divided and saved to multiple volumes of media. If you don't want to divide the file, press the Cancel button, and re-save it to larger-capacity media.

For details, please see "If the data being saved does not fit on one volume of media" on page 408 of the Parameter Guide.

**10. When saving ends and you return to the Save page, the display will show the file that was saved.**

The various types of data are saved as the following files.

- .PCG file
- .SNG file
- .KSC file
- .KMP file
- .KSF file

*Note:* A directory of the same name as the .KSC file will be created inside the directory containing the .KSC file,

and the multisamples (.KMP files) and samples (.KSF files) will be created inside this new directory.

## Cautions when saving

### If an identically named file exists on the media

If a file with the same name already exists on the media, you will be asked whether you want to overwrite. If you wish to overwrite, press the OK button. If you wish to save without overwriting, press the Cancel button, re-do the operation from step 6, and rename the data in step 7 before saving it.

### Please note when saving

- When using **Save All**, **Save PCG & SNG**, and **Save PCG** to save combinations, you should also remember to save the programs used by each timbre (or the drum kits, and RADIAS formant motions used by the programs) at the same time. Similarly when saving programs, you should also remember to save the drum kits, user Drum Track patterns and RADIAS formant motions used by the programs.

- If your programs or drum kits use multisamples and samples that were created in on M3, we recommend that you use **Save All** to save the data.

When you use **Save PCG** or **Save Sampling Data** to individually save a program or drum kit, or a multi-sample or sample that you created, we recommend that you save them under the same filename in the same directory. When you use "Load PCG" to load a .PCG file, the identically-named .KSC file will also be loaded so that the correct multisamples/samples will correspond automatically.

### Time required when saving data

- The length of time required will depend on the amount of data.

## Using the M3 as a data filer

The M3 can receive MIDI System Exclusive data sent by an external device, and save this data to media. (This is sometimes referred to as "Data Filer" functionality.) For details, please see "Save Exclusive" on page 411 of the Parameter Guide.

# Loading data

## Data that can be loaded

### Loading from media

You can load the following data from media.

- **.PCG file:**  
Programs, Combinations, Drum Kits, Global settings, RADIUS Formant Motions (if the optional EXB-RADIUS is installed), and user Drum Track patterns
- **.SNG file:**  
Song and cue list.
- **.KMP file:**  
Korg Multisample Parameter file (KORG format)
- **.KSF file:**  
Korg Sample File (KORG format)
- **.KSC file:**  
Korg SScript file (KORG format)
- **.AIF file:** AIFF file
- **.WAV file:** WAVE file
- **.SF2 file:** Sound Font file
- **.AKAI** format Program/Sample file
- **.KCD file:**  
Audio CD track list
- **.MID file:**  
Standard MIDI file (SMF) format
- **.EXL file:**  
MIDI exclusive data

### Loading the preloaded data and demo songs to restore the factory settings

You can load the preloaded data and demo songs back into the M3's internal memory. For the procedure, please see "Loading the preloaded data" on page 201.

- **Preload data:**  
Programs, Combinations, Drum Kits, Global settings, RADIUS Formant Motions (if the optional EXB-RADIUS is installed)
- **Demo song data**

## Loading data from media (Media-Load)

### Loading all Programs, Combinations, and Drum Kits

Here we'll explain how to load all data from a .PCG file containing Programs, Combinations, Drum kits, Global settings, and Drum Track patterns in a single operation.

- ▲ When loading Programs, Combinations, Songs, or Drum Kits, you must make sure that the Global mode memory protect setting is unchecked. (See "Memory protect" on page 142)

*Note:* Please see page 142 for details on the media from which you can load data.

1. **Make sure that the media is ready for you to load data.** (See "Media setup" on page 143)
2. **Access the Media- Load page.** Press the Load tab.
3. **Press the .PCG file containing the program and combination data you want to load, so that the file is highlighted.**
  - Press **Media Select** to select the media.
  - If there are directories, press the Open button to move to a lower level, or press the Up button to move back to the higher level.

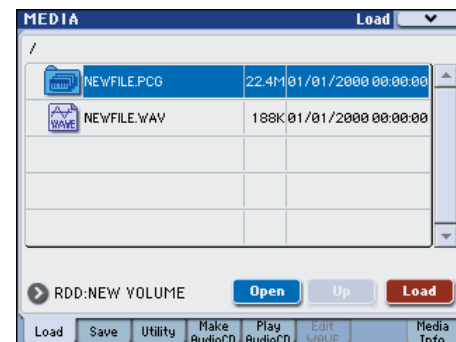

4. **Press the Load button. Alternatively, choose the menu command "Load Selected."**

A dialog box will appear.

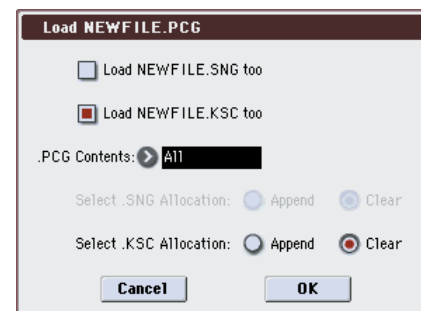

5. **If you also want to load programs that use user multisamples, check the "Load \*\*\*\*\*.KSC too" check box.**



When you execute the load operation, the .KSC file will be loaded along with the .PCG file.

Then use “Select .KSC Allocation” to specify where the Multisamples and Samples will be loaded.

Append will load the data into locations starting with the vacant number following the Multisamples or Samples already loaded in RAM, without leaving any gaps.

Clear will erase all Multisamples and Samples already loaded in RAM, and will then load the data in the same configuration as when it was saved.

**6. Set “.PCG Contents” to All.**

When you execute the load operation, all data in the .PCG file will be loaded.

*Note:* You can load individual banks of Programs and Combinations. For details, please see “1) Load .PCG” on page 399 of the Parameter Guide.

**7. Press the OK button. All data from the .PCG file will be loaded into the M3.**

 Never remove the media while data is being loaded.

**Loading individual banks from a .PCG file**

The M3 lets you load Programs, Combinations, Drum kits, user Drum Kit patterns, RADIAS Formant Motions (if the optional EXB-RADIAS is installed) individually or by individual banks. This is a convenient way to rearrange Combinations in the order in which you will use them during a live performance.

 Be aware that if you change the order of Programs, the sounds played by Combinations may also be affected.

As an example here, we will explain how a combination saved in bank INT-A can be loaded into USER-A000.

**1. Move to the “Bank INT-A” directory, and select the Combination that you want to load. (.PCG file/Combinations/Bank INT-A/)**

The procedure is as follows.

- Perform steps 1–3 under “Loading all Programs, Combinations, and Drum Kits” on page 145. Select the .PCG file containing the data you want to load (it will be highlighted), and press the Open button.
- Press “Combinations” to highlight it, and press the Open button.
- Press “Bank INT-A” to highlight it, and press the Open button.
- Press the scroll bar to find the Combination you want to load, and highlight it in the display.

Alternatively, you could select any file, since the desired file can be selected later from the dialog box.



*Note:* When you press the keyboard of the M3, the selected combination will sound. However, the internal programs will be used as the program of each timbre.

**2. Press the Load button. Alternatively, choose the menu command “Load Selected.”**

A dialog box will appear.

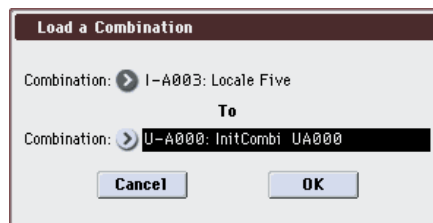

**3. Use the “Combination” (upper line) to select the load-source combination, and use “(To) Combination” (lower line) to specify the destination combination. For this example, select U-A000.**

You can press the popup button and select from a menu, or use the BANK SELECT switches and numeric keys to make a selection.

**4. Press the OK button to execute loading; the loaded combination will be assigned to USER-A000.**

**Loading songs for use in Sequencer mode (.SNG)**

As an example here, we will explain how to load a song. We’ll assume that this song uses edited programs and programs that use multisamples you sampled. In such cases, it is best to load “all data.”

**1. Perform steps 1–3 under “Loading all Programs, Combinations, and Drum Kits” on page 145. Select the .SNG file containing the data you want to load (it will be highlighted).**

**2. Press the Load button. Alternatively, choose the menu command Load Selected.**

A dialog box will appear.

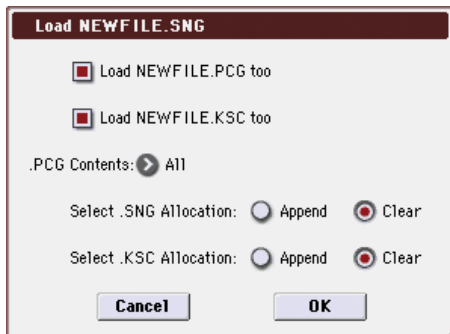

*Note:* The contents and settings of the dialog box will differ depending on the type of file that you are loading.

### 3. Check the “Load \*\*\*\*\*.PCG too” check box.

When you execute loading, the .PCG file will be loaded along with the .SNG file.

Check the “Load \*\*\*\*\*.KSC too” check box.

When you execute loading, the .KSC file will be loaded along with the .SNG file.

Use “.PCG Contents” to specify the data that you want to load.

If you want to load all the data in the .PCG file, select All.

Use “Select .SNG Allocation” to specify the destination to which the song data will be loaded.

“Append” will load the song into the song number that follows the song(s) currently existing in internal memory, without leaving a vacant number.

“Clear” will erase all songs from internal memory, and load the songs into the numbers from which they were saved.

Use “Select .KSC Allocation” to specify where the multisamples and samples will be loaded.

“Append” will load the data into the next available vacant numbers following the multisamples and samples that are already in sample memory (RAM).

“Clear” will erase all multisamples and samples from sample memory (RAM), and load the data in the same configuration with which it was saved.

### 4. Press the OK button to execute loading.

 Never remove the media while data is being loaded.

## Loading M3 system update data

You can update the M3’s system by downloading the most recent version of the system file from the Korg website (<http://www.korg.com>) to your computer, and loading it into the M3. For details on the procedure, refer to the Korg website and to “Update System Software” on page 384 of the Parameter Guide.

Use the Global mode command **Update System Software** to load the system update data.

## Media utility

### File copying, deleting, and formatting (Media– Utility)

Here we'll explain how to format media and how to set the date and time that are written into the file when you save data. For other media utility functions, please see "0–3: Utility Menu Command" on page 412 of the Parameter Guide.

#### Formatting media

Newly purchased media or media that has been used by another device cannot be used "as is;" you must format the media before you can use it with the M3.

*Note:* When creating audio CDs, you don't need to format the CD-R/RW media.

⚠ When you format, all data saved on that media will be erased. If you had used a computer etc. to set up that drive so that it can be used as multiple drives (partitions), this data will also be erased. Be sure to double-check before you format.

⚠ After formatting, it is not possible to press the COMPARE switch to return to the previous state.

1. Make sure that the media you want to format is inserted. (See "Media setup" on page 143)
2. Access the Media– Utility page. Press the Utility tab.
3. Press Media Select, and choose the drive that you want to format.
4. Press the menu button to access the menu, and press "Format" to open the dialog box.

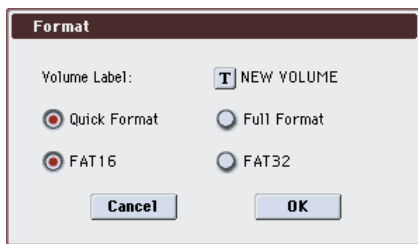

5. In "Volume Label," use the text edit button to access the text edit dialog box, and specify the volume label.

The previously-specified volume label will be displayed. If no volume label had been specified for the media, or if a non-DOS media was inserted, this will indicate "NEW VOLUME."

#### 6. Specify the initialization format.

**Quick Format:** Normally you should use Quick Format to initialize the media.

Select this if the media has already been physically formatted, or if you want to format media that has been UDF-formatted by the M3. Since only the system area of the media need be formatted, this will require less time.

**Full Format:** Select this when formatting media that has not been physically formatted, or media (CD-RW) that has not been UDF-formatted.

*Note:* Normally, it is not necessary to perform a Full Format on media that has been physically formatted at 512 bytes/block. Execute the Quick Format for such media.

*Note:* You will normally select Full Format for CD-RW media etc. that has not been UDF-formatted. If an error message of "Media not formatted" appears, execute Full Format.

Depending on the capacity of the media, executing Full Format may require a substantial length of time.

#### 7. Specify the file system.

Use FAT16 to format media of 4 GB or less (such as flash media), and use FAT32 to format larger media (theoretically, up to 2 Terabytes).

*Note:* CompactFlash cards and Micro Drives of 4 Gbytes or less will be formatted as FAT16.

#### 8. Press the OK button to format, or press the Cancel button if you decide to cancel.

When you press the OK button, a message will ask you for confirmation. Press the OK button once again to execute the Format operation.

⚠ You must format a CD-R/RW disc if you want to use it for packet writing, or if it has previously been used by another device.

You do not need to format a CD-R/RW disc that you will use to create an audio CD.

⚠ You must use the M3 to format the media. The M3 will not correctly recognize media that has been formatted by another device.

### Setting the date and time

M3 has an internal calendar, which is used to record the date and time when you save data. You can set the date and time by using the Media Utility page's **Set Date/Time** menu command.

You will need make these settings after you purchase the M3, and after you replace the calendar backup battery.

1. Press the MODE MEDIA switch to enter Media mode.
2. Access the Media– Utility page. Press the Utility tab.
3. Open the menu, and select the Set Date/Time command.

The following dialog box will appear.

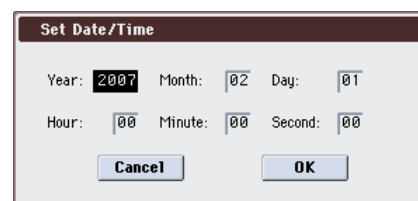

4. Use the VALUE controllers to set the correct year, month, day, hour, minute, and second.

**5. Press the OK button.**

 If the calendar backup battery runs low, a message of “The clock battery voltage is low.” will appear on the display. If the calendar backup battery runs down completely, the calendar will be initialized, and the date and time will not be recorded correctly.

*Note:* You can replace the calendar backup battery by yourself. For details, please see “Specifications and options” on page 224.

## Creating audio CDs

### Creating and playing audio CDs (Media– Make Audio CD, Play Audio CD)

You can use Sequencer mode to create WAVE files by resampling your songs (see page 127), and place these WAVE files in the desired order to create an audio CD.

*Note:* You'll need a commercially available USB CD-R/RW drive and media.

### Connecting your USB CD-R/RW drive and USB storage device

1. Using a USB cable, connect the USB storage device containing your WAVE files to the M3's USB A connector.

Using another USB cable, connect your CD-R/RW drive to the M3's other USB A connector.

*Note:* The M3's USB A connectors support hot-plugging; you can connect or disconnect the USB cable while the power is on. However in order to do so, your USB storage device must also support hot-plugging.

2. Turn on the power of the M3.
3. Turn on the power of your USB storage device, and use a USB cable to connect the USB port of your USB storage device to the USB A connector of the M3.

*Note:* The above step assumes that your USB device supports hot-plugging. If you are using a device that does not support hot-plugging, connect it with the power turned off.

4. While the M3 is accessing the USB device, do not connect another USB device or disconnect the connected device. Doing so may damage your data.
4. Press the MODE MEDIA switch to enter Media mode.
5. Press the Media Info tab, and then execute the menu command "Scan USB device."

If you are using a removable disk, insert the media. After you exchange media in your USB device, press the display to make the M3 detect the media. When the media has been detected, information about the media will appear on the display.

4. Make sure that the USB storage device containing your WAVE files and the media in the USB CD-R/RW have been detected.
4. When writing data to CD-R/RW media, the media containing the WAVE files must have free space equal in size to the WAVE files you are writing. Before you execute this operation, make sure that the drive containing the WAVE files contains enough free space.

### Creating audio CDs

#### Part 1: 2ch Mix to Media

If you're starting with Songs you've created in Sequencer mode, you'll first need to bounce the Songs to WAVE files on the USB storage device (commercially available hard disk, etc.).

1. In Sequencer mode, select the first song that you want to burn to the CD.
2. In the 0-7: Sampling/Audio In page, sample the song to create a WAVE file. For details on creating a WAVE file, refer to "Resampling a song to create a WAVE file."
3. Repeat the steps above for all of the Songs that you'd like to burn to the CD, and then proceed to Part 2 below.

#### Part 2: Making the CD

1. Access the Media– Make Audio CD page.

Press the Make Audio CD tab.

In the default state, the WAVE File area will show only "====End====."

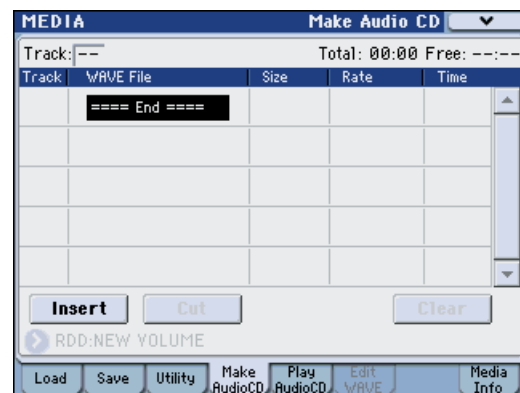

2. To the track list, add the WAVE files that you want to write to the CD.

Select "====End====" (it will be highlighted), and press the Insert button.

The Insert Track dialog box will appear.





Use media select and the Open and Up buttons to access the directory that contains the WAVE file, and select the WAVE file that you want to add to the list. If you want to audition the file, you can press the SAMPLING START/STOP switch to play back the sample.

- ⚠ If you have selected a WAVE file with a sampling frequency other than 44.1 kHz or 48 kHz, it will not be possible to press the Insert button.
- ⚠ WAVE files at a sampling frequency of 48 kHz will be converted to 44.1 kHz when they are written to an audio CD (when you execute **Write to CD**).

To add the file, press the Insert button.

You can continue adding files until you press the Exit button. The files will be added to the track list in the order in which you selected them. If you want to add all the WAVE files in the directory, press the Insert All button.

When you have finished adding files to the list, press the Exit button to close the dialog box.

Notice that the WAVE files have been added to the track list.

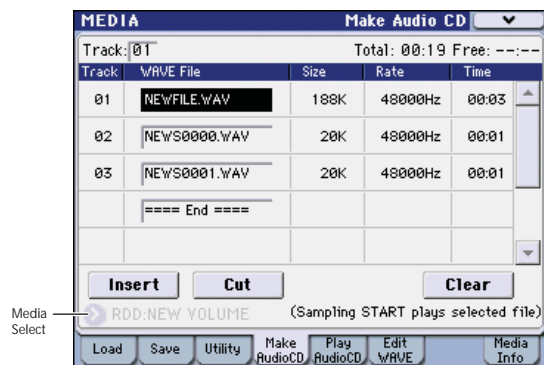

If you select a WAVE file in this page whose sampling frequency of 44.1 kHz or 48 kHz, you can also use the Play button to play the sample.

To add other WAVE files to the track list, press the Insert button once again.

If you want to add another track, select the WAVE file that follows the track you want to add. If you want to add the track to the end of the track list, select "====End====." Then press the Insert button.

To delete a WAVE file from the track list, select the WAVE file that you want to delete, and press the Cut button. Subsequent tracks will be moved forward in the list.

*Note:* For more details on other editing operations, please see "0-4c: Media Select, Command buttons" on page 394 of the Parameter Guide, and "Swap Track" on page 415 of the Parameter Guide.

### 3. Insert a blank CD-R or CD-RW media into the drive.

In the Make Audio CD page, use **Media Select** to select the internal CD-R/RW drive or an external USB CD-R/RW drive (commercially available). The CD-R/RW drive is shown as "CDD: Blank Disc."

- ⚠ An audio CD cannot be created on a disc that contains data other than audio (e.g., files). In this case, it will not be possible to select the menu commands **Write to CD** or **Finalize Audio CD**.

*Note:* Even when the recommended CD-R/RW media is used, some audio CD players may be unable to play back the disc. Also, since some audio CD players are unable to play back CD-RW media, we recommend that you use CD-R media.

### 4. Select the menu command "Write to CD" to access the dialog box, and specify how the CD will be written.

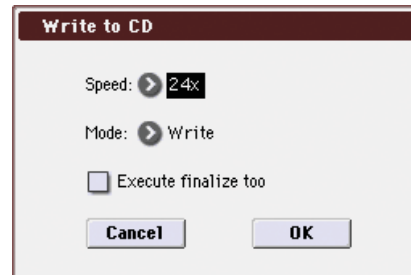

Use **Speed** to set the writing speed. This will indicate the speeds supported by the CD-R/RW drive you are using. Here you should set **Speed** to the lowest speed that can be selected.

- ⚠ Be aware that if you use a faster writing speed in a slower system, writing errors will occur.

Use **Mode** to specify the writing method.

*Note:* Depending on the drive you are using, it may not be possible to write at the specified speed. We recommend that the first time you write, you select **Test** to perform a writing test in order to determine the speed capabilities of your drive. **Test** will not write data to the CD-R/RW media, but will perform all other processing just as when data is actually written. If an error occurs, the display will indicate "Error in writing to medium."

Press the OK button to execute the writing test.

After verifying that data can be written correctly at the specified speed, select **Write**.

"Execute finalize too" specifies whether Finalization will be executed after the audio tracks have been written to the CD-R/RW media. If finalization has been executed, the disc can be played back on a CD player, but it will no longer be possible to add more tracks.

*Note:* If you only want to execute finalization, execute "Finalize Audio CD."

### 5. When you are ready to write to the CD-R/RW media, or to execute a writing test, press the OK button. To cancel without executing, press the Cancel button.

- ⚠ When you press the OK button, the "Obey Copyright Rules" dialog box will appear. Carefully read "COPYRIGHT WARNING" on page iii, and if you consent to the terms, press the OK button to begin burning the CD. If you do not consent to the terms, press the Cancel button to cancel the operation.

- ⚠ In order to avoid causing errors, do not subject the drive to physical shock or vibration while CD-R/RW media is being written.

## Auditioning an audio CD you've finalized

Here's how you can use a CD-R/RW drive connected to the USB A connector to play back an audio CD that you've finalized.

⚠ If your CD drive does not have an audio output jack, headphone jack, or S/P DIF OUT jack, you won't be able to monitor the sound.

1. **Connect the audio output jack (or headphone jack) of your USB CD-R/RW drive to the M3's AUDIO INPUT 1, 2 jacks.**

Alternatively, you can monitor the sound by connecting the S/P DIF OUT jack of your CD-R/RW drive to the M3's S/P DIF IN jack.

2. **Press the Play Audio CD tab to go to the Play Audio CD page.**

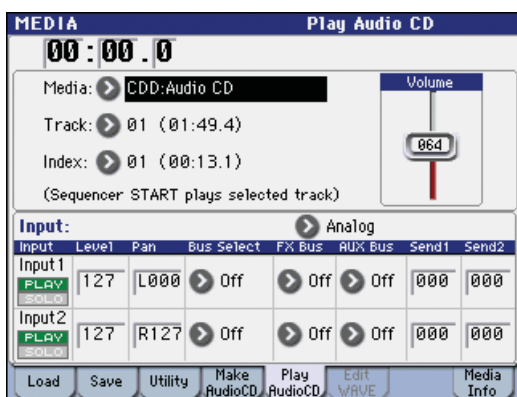

In **Media Select**, select your CD-R/RW drive.

**Media Select** will indicate Audio CD.

To allow monitoring, set the Input as follows.

**INPUT1: Bus Select L/R, FX Bus Off, AUX Bus Off, Send1/Send2 000, Pan L000, Level 127**

**INPUT2: Bus Select L/R, FX Bus Off, AUX Bus Off, Send1/Send2 000, Pan R127, Level 127**

**Volume:** as desired

Use **Track** to select the track, and press the **SEQUENCER START/STOP** switch to begin playback.

## Saving Track Lists

The track list will be lost when the power is turned off. If you want to keep this data, you must save it.

1. **In the Save page, select the directory in which you want to save the track list.**
2. **Select the menu command "Save Audio CD Track List" to open the dialog box.**
3. **Press the OK button to save the data, or press the Cancel button to cancel without saving.**

## Viewing information about media – Media Info

This displays information about the media selected in "Media Select."

## Mounting USB storage devices

Use the Media Info menu command **Scan USB device** to mount a device connected via USB A. For details, please see "Scan USB device" on page 419 of the Parameter Guide.

# Using Effects

## An overview of the M3's effects

For effects processing, the M3 provides five insert effects, two master effects, and one total effect, together with a mixer section that controls the routing of these effects. All of these are stereo in/out.

Specific parameters of these effects can also be controlled in real time from the M3's controllers or via MIDI messages using Dynamic Modulation (Dmod), by MIDI/Tempo Sync, or by using a common LFO to apply synchronized change to differing modulation effects.

## Effect types

You can choose from 170 different full-digital effects. The effects are categorized as follows.

*Classification of 170 effects*

Effect type	Contents
Dynamics: 000...005	Effects which control volume, such as compressors, limiter, and gates
EQ/Filter: 006...017	Effects which control frequency content, such as EQ, multi-mode filter, exciter, and wah
Overdrive/ Amp/Mic: 018...025	Overdrive and amp modeling effects such as guitar/bass amps and mics
Chorus/ Flanger/ Phaser: 026...039	Pitch and phase modulation effects such as chorus and flanger
Modulation/ Pitch Shift: 040...054	Other modulation effects such as tremolo and rotary speaker, and pitch shifters
Delay: 055...069	Delays
Reverb/ER: 070...076	Reverb and early reflections
Mono-Mono Serial: 077...108	Mono & Mono chain effects that internally connect two mono effects in series
Mono//Mono Parallel: 109...153	Mono & Mono parallel effects that allow two mono effects to be applied to L and R independently
Double Size: 154...170	Double size effects

## Effect I/O

### Insert effects

Insert Effects (IFX 1–5) are stereo-in/stereo-out. If you select Dry (unprocessed) for the **Wet/Dry** parameter, the stereo input signal will be output in stereo without being processed by the effect. If you select Wet (effect applied), the processed signal will be output in one of the following ways:

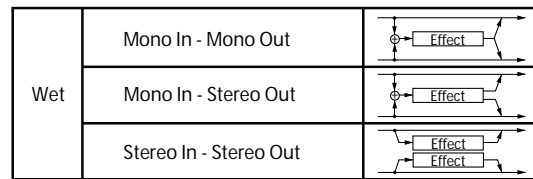

### Master Effects

The I/Os of Master Effects MFX1 and MFX2 are stereo-in/stereo-out. **Send1** and **Send2** determine the send level to the Master Effects.

Master effects will not output the Dry (unprocessed) signal specified in **Wet/Dry**. Only the Wet (processed) signal will be output. The output signals from the Master Effects are routed to the L/R bus with the output level specified by **Return1** and **Return2**. These output signals are mixed with the output signals from the bus specified by **Bus Select** (P8– Routing page in each mode) L/R, or with the output signals from the bus specified by **Bus Select** (P8– Insert FX Setup page in each mode) L/R, then routed to the total effect.

Selecting “000: No Effect” will mute the output. The processed signal will be output in one of the following ways, according to the type of effects.

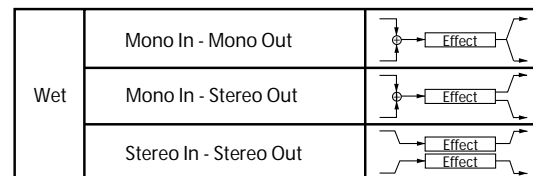

### Total Effect

The total effect TFX is stereo-in/stereo-out. The Dry (unprocessed) side of the **Wet/Dry** parameter sends the stereo input sound directly to the stereo output. The way in which the Wet (processed) side is output depends on the type of effect, as follows.

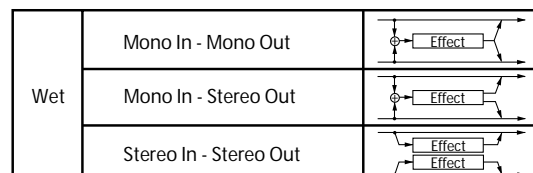

*Note:* The Parameter Guide includes block diagrams for each individual effect, which include the effect's input/output structure. (See PG page 438)

## Effects in each mode

### Program mode

For programs of EDS, you can use insert effects to process the final sound in the same way that you use the Filter, Driver, Amplifier, and EQ (equalizer) to process the sound from the oscillators (OSC 1 & 2). Then the master effects are used to create overall ambience such as reverb, and use the total effect to make final adjustments. All of these settings can be made independently for each program.

### Combination and Sequencer modes

In Combination and Sequencer modes, you can use the track EQ and insert effects to process the program sound of each timbre/track. Then you can use the master effects to create overall ambience, and use the total effect to make final adjustments.

In Combination mode you can make these settings for each combination, and in Sequencer mode you can make them for each song.

In Sequencer mode, you can switch between effects or modify the effect parameters and record these changes, so that effects will switch automatically or effect parameters will be modified automatically as the song plays back.

### Sampling mode

In Sampling mode, external audio sources from AUDIO INPUT 1, 2, and S/P DIF IN jacks by insert effects, master effects, and total effect, and then

sampled. Use the P0: Recording– Audio In/Setup page to make audio input settings for Sampling mode. These settings apply only to Sampling mode.

Samples that you've assigned as a multisample can also be processed by the insert effects, master effects, and total effect, and then resampled.

### Audio Input

You can also input audio sources from AUDIO INPUT 1, 2, and S/P DIF IN jacks in modes other than Sampling mode (i.e., in Program, Combination, and Sequencer modes).

You can apply the insert effects, master effects, and total effect to external audio sources from these jacks and sample them, or use the M3 as a 4-in (AUDIO INPUT 1, 2, S/P DIF IN L, R) 6-out effect processor.

You can also use an external mic input to control a vocoder effect (156: Vocoder), and modulate the internal sounds. For examples, please see "Example: Vocoder (Program)" on page 424 of the Parameter Guide and "156: Vocoder" on page 515 of the Parameter Guide.

Use the P0: Play– Sampling/Audio In page of each mode to make audio input settings. Alternatively, you can check **Use Global Setting** and make these settings in the Global mode P0: Basic Setup– Audio page. Normally you will leave **Use Global Setting** checked. Uncheck this if you want programs and combinations to use their own settings. For example when writing the program as a vocoder effect program.

*Note:* If the optional EXB-FW is installed, you'll be able to use FireWire input and output. This will give you a total of 6-in and 6-out.

Program mode

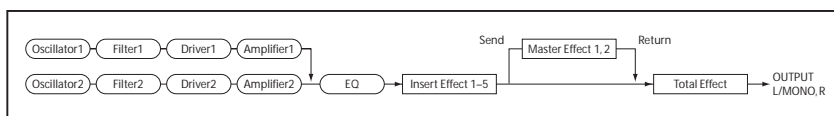

Combination and Sequencer modes

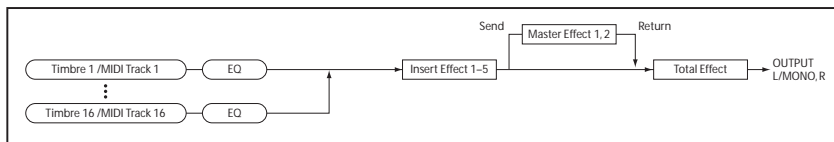

Sampling mode

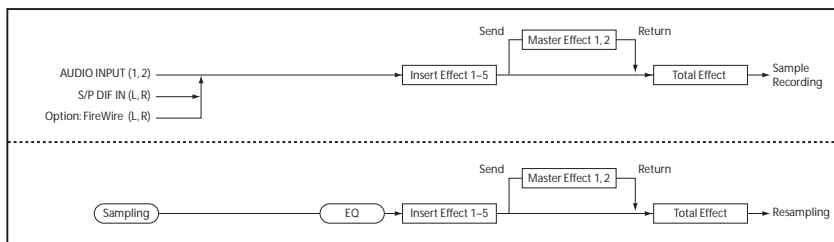

Audio Input

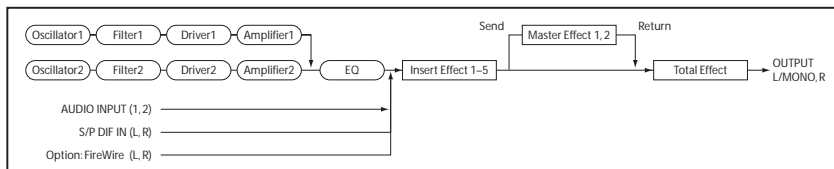

# Routing effect settings

The insert effects, master effects, and total effect have the same structure in all modes, but the routing settings will determine how the oscillators of a program or the timbres of a combination or track of a song will be sent to each insert effect, master effect or total effect. In the pages that follow, we will explain how you can make routing settings and effect settings in each mode.

## Program Effects settings

### Routing

1. Access the Prog P8: IFX– Routing page.

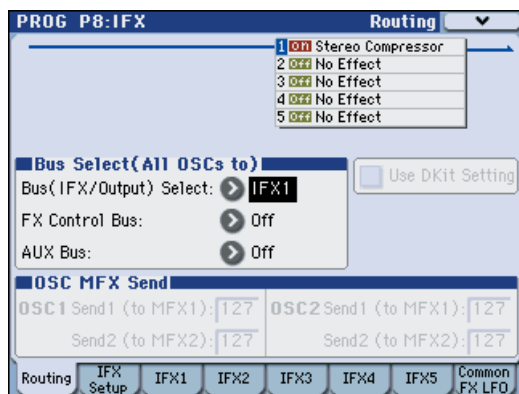

2. Use **Bus (IFX/Output) Select** to specify the bus to which the oscillator output will be sent. If you want the oscillator output to be input to insert effect 1, choose **IFX1**.

**L/R:** The output will not be sent to the total effect. After passing through the total effect, the sound will be sent to AUDIO OUTPUT (MAIN) L/MONO and R.

**IFX1–5:** The output will be sent to insert effect IFX 1–5.

**1–4, 1/2–3/4:** The output will be sent to AUDIO OUTPUT (INDIVIDUAL) 1–4. It will not be sent to the insert effects, the master effects, or the total effect.

**Off:** The output will not be sent to AUDIO OUTPUT (MAIN) L/MONO, R, or to (INDIVIDUAL) 1–4. Choose this if you want the signal to be series-connected to the master effects at the send levels specified by **Send 1 (to MFX1)** and **Send 2 (to MFX2)**.

3. **OSC MFX Send** specifies the send level from each oscillator to the master effects.

This can be set only when **Bus (IFX/Output) Select** is either L/R or Off.

If **Bus (IFX/Output) Select** is set to IFX1–5, the send level to the master effects is set by **Send1** and **Send2** (Insert FX Setup page) after the signal passes through the insert effects.

4. **“FX Control Bus”** sends the oscillator 1 and 2 output to the FX Control bus. Use this if you want the audio input to the effect to be controlled by a different sound.

You can use the two FX Control buses to control effects freely. (See “FX Control Buses” on page 423 of the Parameter Guide)

5. **AUX Bus** sends the oscillator 1 and 2 output to the AUX buses.

In the P0: Play– Sampling/Audio In page, you can set the Sampling Setup **Source Bus** to a AUX bus, and sample the signal being sent to the AUX bus. Normally you will turn this Off, since you will usually set **Source Bus** to L/R when sampling the output of oscillator 1 and 2.

### Insert effects

6. Access the Prog P8: IFX– Insert FX Setup page.

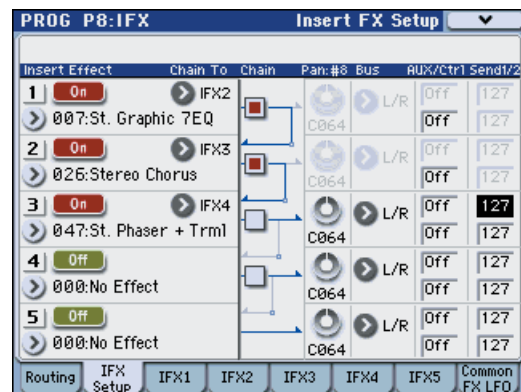

7. Choose the effect type that you want to use for each insert effect IFX1–5.

When you press the popup button, all effects will be displayed, organized into ten categories. Use the pages located at the left and right to select a category, and select an effect from that category on the display.

You can use the **Copy Insert Effect** menu command to copy effect settings from another program etc. Also, you can use **Swap Insert Effect** to exchange (for example) IFX1 and IFX5.

8. Press the **On/Off** button to turn on the insert effect.

Each time you press the button, the insert effect will be switched on/off. When Off, the result will be the same as when 000: No Effect is selected. The input sound will be output without change.

9. **Make Chain settings.**

If the **Chain** check box is checked, the insert effect will be connected in series. Since the output of the oscillator is being sent to IFX1 in step 2, making settings as shown in the diagram step 6 would connect all five insertion effects IFX1 → IFX2 → IFX3 in series, so that these effects would be inserted into the output of the oscillator.

10. **Make settings for Pan: #8, “Bus (Bus Select),” “Send 1,” “Send 2,” “AUX Bus” and “Ctrl Bus” for the sound after it has passed through the insert effects.**

If you’ve specified a chain, the settings that follow the last IFX in the chain will be valid (except for **Ctrl Bus**).

**Pan:** Sets the pan of the IFX output.

**Bus (Bus Select):** Specifies the output destination. Normally you will set this to L/R. If you wish to send the sound that has passed through the insert effects to



AUDIO OUTPUT (INDIVIDUAL) 1–8, select 1–4, 1/2, or 3/4.

**Send 1, Send 2:** Sets the send levels to the master effects. For this example, set this to 127.

**Ctrl Bus:** The FX Control Buses lets you create effects “sidechains.” Sidechains let you control an effect with one audio signal (the sidechain), while the effect processes a completely different audio signal. This is convenient for use with vocoders, compressors and limiters, gates, etc. For details, please see “FX Control Buses” on page 423 of the Parameter Guide.

**AUX Bus:** The sound processed by the insert effect will be sent to the AUX bus. In the P0: Play– Sampling/ Audio In page, you can set the Sampling Setup **Source Bus** to a AUX bus, and sample the signal that is sent to the AUX bus. Use this if you want to sample only the sound of an audio input source being processed by an insert effect (and not sample the sound of the oscillator output). Alternatively, the direct sound from the audio inputs can be mixed with the sound processed by an insert effect, sent to a AUX bus, and sampled.

**11. Access the P8: IFX– IFX page, and edit the parameters of the insert effect you selected.**

Press the IFX 1–5 tabs and edit the parameters.

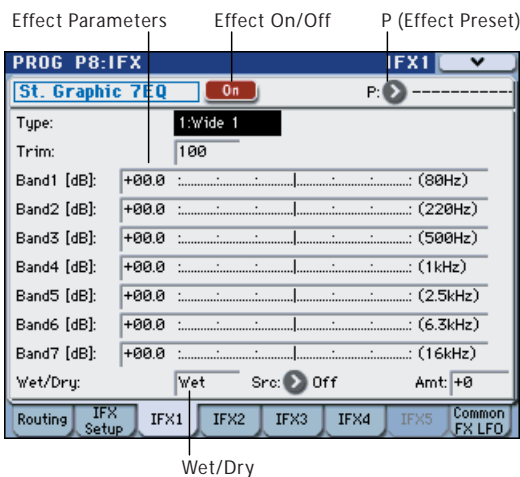

**Effect 1 On/Off:** Turns the insert effect on/off. This is linked with the on/off setting in the Insert FX Setup page.

**P (Effect Preset):** Selects an effect preset. The M3’s internal memory contains “effect presets” which are parameter settings for each effect from 001: Stereo Compressor through 170: Early Reflections.

Effect parameters you edit are saved as part of each program, but effect presets allow you to save favorite parameter settings for each effect. If you’ve come up with an effect setting you like, use the menu command **Write FX Preset** to save it as a preset so that you can easily recall it in a different program or mode.

For details on the individual effects, please see:

- “Dynamics (Dynamic)” on page 441 of the Parameter Guide
- “EQ and Filters (EQ/Filter)” on page 445 of the Parameter Guide
- “Overdrive, Amp models, and Mic models (OD Amp Mic)” on page 453 of the Parameter Guide
- “Chorus, Flanger, and Phaser (Cho/Fln Phaser)” on page 458 of the Parameter Guide

- “Modulation and Pitch Shift (Mod./P.Shift)” on page 465 of the Parameter Guide
- “Delay” on page 476 of the Parameter Guide
- “Reverb and Early Reflections (Reverb ER)” on page 486 of the Parameter Guide
- “Mono-Mono Serial (Mono-Mono)” on page 488 of the Parameter Guide
- “Mono/Mono Parallel (Mono//Mono)” on page 504 of the Parameter Guide
- “Double Size” on page 514 of the Parameter Guide

**Double-size effects**

Double-size effects (154: St.Mltband Limiter – 170: Early Reflections) use twice as much space as other effects.

You can use double-size effects for insert effects IFX1–IFX4 and master effect MFX1. However, the effect of the number that follows it will be unavailable. For example if you’ve selected a double-size effect for IFX1, you won’t be able to use IFX2. If you’ve selected a double-size effect for MFX1, you won’t be able to use MFX2.

*An example of when a double-size effect is selected for IFX1 and IFX4*

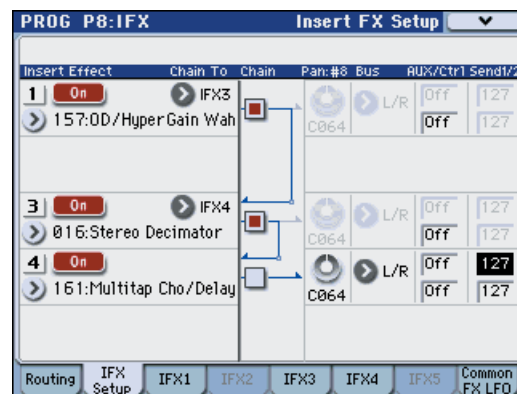

**Master effects**

**12. The input levels to the master effects are set by the “Send 1, 2” levels (step 3 or 10). If “Send 1, 2” are zero, the master effects will not apply. “Send 1” corresponds to MFX1, and “Send 2” corresponds to MFX2.**

**13. Access the Prog P9: MFX/TFX– Routing page.**

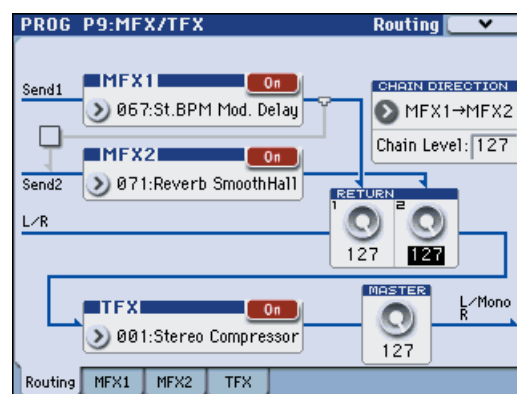

**14. In MFX1 and MFX2, select the type of each master effect.**

The procedure is the same as when selecting an insertion effect (see step 7).

*Note:* You can select a double-size effect only for MFX1. (See “Double-size effects” on page 156)

**15. Press the On/Off button to turn on the master effect.**

Each time you press the button, the master effect will be switched on/off. When Off, the output of the master effect will be muted.

**16. Use “Return 1” and “Return 2” to adjust the output levels of the master effects.**

*Note:* For each effect, the Wet value of the Wet/Dry parameter is the output level at the effect. The return value is multiplied with this (“Return” = 127 will be x1.0) to determine the actual output level of the master effect.

**17. Select the MFX1 and MFX2 pages, and set the parameters for each selected effect.**

For details on the “Program Effects settings” step 11.

## Total Effect

**18. If you use “Bus (IFX/Output) Select” to choose L/R as the oscillator output, or if you set the post-IFX Bus Select to L/R, the signal will be input to the total effect.**

The output from the master effects is input to the total effect via the “Return 1” and “Return 2” settings of the Prog P9: MFX/TFX– Routing page.

After being processed through the total effect, the signal is output from the AUDIO OUTPUT (MAIN) L/MONO and R outputs.

**19. Access the Prog P9: MFX/TFX– Routing page.**

**20. Choose the desired total effect for TFX. The procedure is the same as when selecting an insert effect. (See step 7)**

You can’t use a double-size effect as the total effect. (See “Double-size effects” on page 156 of the Parameter Guide)

**21. Press the On/Off button to turn the total effect on.**

The total effect will be switched on/off each time you press the button. If this is Off, the result will be the same as if 000: No Effect is selected. The input sound will be output without change.

**22. Access the TFX page, and edit the parameters of each effect to adjust the final sound as desired.**

For details on the “Program Effects settings” step 11.

## Using effects in Combinations and Songs

In Combination, and Sequencer modes, you can specify the routing of each timbre/track to the insert effects, master effects and total effect. These settings are made in the same way in each of these modes. We will be using the example of Combination mode in our explanation here.

## Routing

**1. Access the Combi P8-1: IFX– Routing1 T01-08 page.**

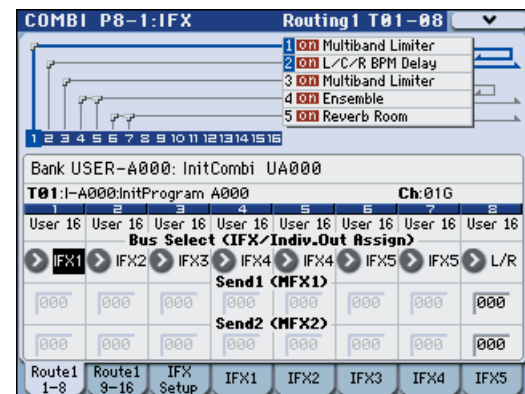

**2. Use “Bus Select (IFX/Indiv.Out Assign)” to specify the bus to which each timbre will be output. Choose IFX1 if you want to send the output of a timbre to insert effect 1.**

The routing, insert effects, and chain settings are shown graphically in the upper part of the page. In this example, T01 (timbre 1) uses IFX1 and 2. T02 uses IFX2, T03 uses IFX3 and 4, T02 and T05 use IFX4, and T06 and T07 use IFX5.

**3. Use Send1 and Send2 to specify the send level of each timbre to the master effects.**

This can be set only if Bus Select (IFX/Indiv.Out Assign) is set to L/R or Off.

*Note:* The actual send level is determined by multiplying this by the Send 1 or Send 2 settings for oscillators 1 and 2 within the program selected by the timbre. If the program parameter Send 1 or Send 2 is set to 0, the resulting level will still be 0 even if you raise this send level.

If Bus Select (IFX/Indiv.Out Assign) is set to IFX1–5, the send levels to the master effects are set by Send1 and Send2 (Insert FX Setup page) following the insert effects.

**4. Access the Combi P8-2: IFX– Routing2 page.**

Bus Select (IFX/Indiv. Out Assign) is the same as in the Routing 1 page. You can set it from either page.

FX Control Bus sends the output of the timbre to an FX Control bus. Use this when you want the audio input to an effect to be controlled by another sound. There are two FX Control buses, which gives you a great deal of freedom for controlling effects freely. (See “FX Control Buses” on page 423 of the Parameter Guide)

AUX Bus sends the output of the timbre to a AUX bus. In the P0: Play– Sampling/Audio In page, you can set

the Sampling Setup **Source Bus** to a AUX bus, and sample the signal that is sent to the AUX bus. Use this if you want to sample only the sound of a specific timbre.

## Insert effects

### 5. Access the Combi P8-1: IFX- Insert FX Setup page.

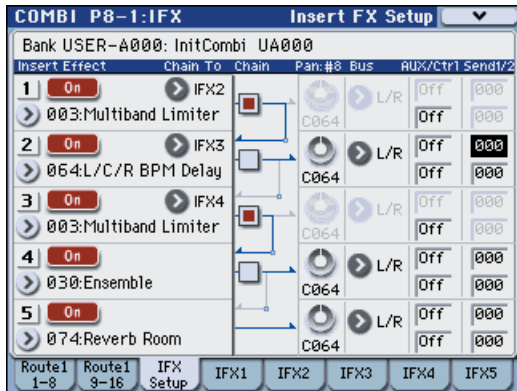

### 6. Select an insert effect in IFX1-5 and edit the settings.

### 7. Access the IFX1-5 pages to edit the individual effect parameters.

These settings can be made in the same way as in “Program Effects settings” on page 155.

**MIDI** You can use MIDI to control dynamic modulation (Dmod) for each effect, the post-IFX pan (CC#8), and Send 1 and Send 2.

An asterisk “\*” is shown at the right of Ch01-Ch16 for the channel number of tracks routed to IFX. If you’ve routed multiple tracks that have differing MIDI channel settings, this specifies the channel on which they will be controlled.

## Master effects and Total effect

These settings can be made in the same way as on page 156.

**MIDI** You can control these effects via MIDI on the “Ctrl Ch.” The specified MIDI channel will control dynamic modulation (Dmod) for the Master and Total Effect.

## Effect settings in Sampling mode

In Sampling mode you can sample from the AUDIO INPUT 1, 2 or S/P DIF IN jacks while applying an effect to the external audio input source. It’s also possible to apply effects to a multisample and resample the result.

## Routing

### Routing of an external input

#### 1. Access the Sampling P0: Recording- Audio In/ Setup page.

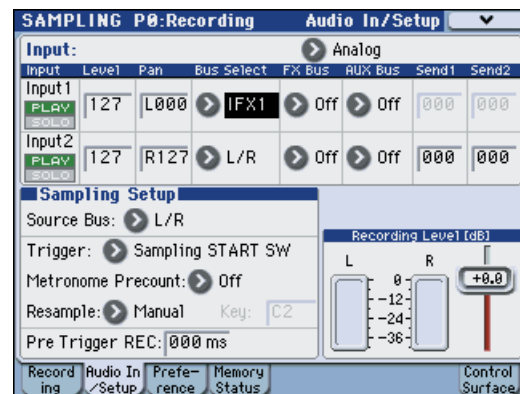

#### 2. In “Input,” select the input source.

#### 3. Use Bus Select to specify the bus to which each audio input will be sent.

For example if you want the output of the device connected to AUDIO INPUT 1 to be routed to insert effect 1, set **Input** to Analog, and set the INPUT 1 **Bus Select** to IFX1.

#### 4. Use Send1 and Send2 to specify the send level of each timbre to the master effects.

This can be set only if **Bus Select** is set to L/R or Off.

If **Bus Select** is set to IFX1-5, the send levels to the master effects are set by **Send1** and **Send2** (Insert FX Setup page) following the insert effects.

#### 5. Use Pan to set the panning of the audio input.

If you’re inputting a stereo audio source, you will normally set the inputs to L000 and R127 respectively.

#### 6. Use Level to adjust the level of the audio input.

Normally you will leave this at 127.

#### 7. FX Control Bus sends the output of the timbre to an FX Control bus.

The FX Control Buses lets you create effects “sidechains.” Sidechains let you control an effect with one audio signal (the sidechain), while the effect processes a completely different audio signal. This is convenient for use with vocoders, compressors and limiters, gates, etc. For details, please see “FX Control Buses” on page 423 of the Parameter Guide.

#### 8. AUX Bus sends the audio input to a AUX bus.

By selecting a AUX bus as the **Source Bus**, you can sample the signal that’s being sent to the AUX bus.

Normally when sampling in this mode, you will turn this Off, since the **Source Bus** will be set to L and R.

### Multisample (sample) routing

If you want to apply an effect to a multisample (sample) and resample it, use the P8: IFX- Routing page **Bus (IFX/Output) Select** setting to specify the bus.

1. Access the Sampling P8: IFX- Routing page.

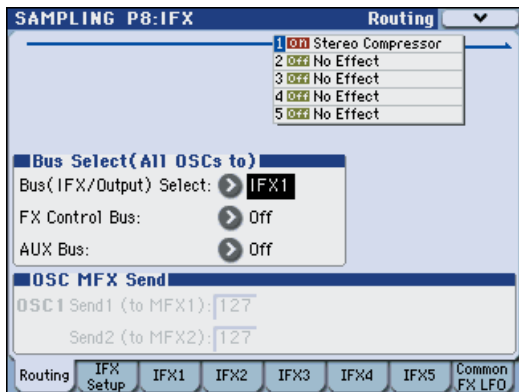

2. Use “Bus (IFX/Output) Select” to specify the bus to which the multisample output will be routed. For example if you want the multisample output to be routed to insert effect 1, choose IFX1.

*Note:* When you sample, the **Bus (IFX/Output) Select** setting will automatically be set to L/R. This setting is made automatically to prevent the IFX from being applied twice when you play back the sample that was sampled using IFX. (In the same way, the MFX1, 2, and TFX On/Off settings will automatically be turned off.) Be aware of this when you sample again.

### Insert effects

1. Access the P8: IFX- Insert FX Setup page.

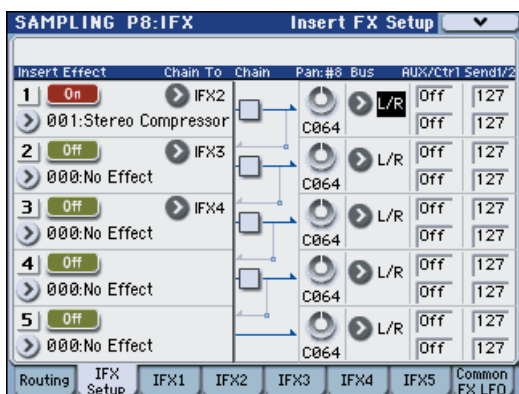

2. Select an insert effect in IFX1-5 and edit the settings.
3. Access the IFX1-5 pages to edit the individual effect parameters.

These settings can be made in the same way as in “Program Effects settings” on page 155.

### Master effects and Total effect

These settings can be made in the same way as in “Program Effects settings” on page 155.

## Effect settings for the audio inputs

You can use effects on the audio input when in Program, Combination, and Sequencer modes, just as you can in Sampling mode.

You can apply insert effects, master effects, and the total effect while sampling, or you can use the M3 as a four-in (AUDIO INPUT 1, 2, S/P DIF L, R) six-out effect processor. You can also use the M3 as a vocoder effect (156:Vocoder) that uses an external mic input to control the internal sounds. For examples of this, see page 424 and “156: Vocoder” on page 515 of the Parameter Guide.

Make these settings in the Global mode P0: Basic Setup- Audio page. The Global mode settings will apply in Program, Combination, and Sequencer modes if **Use Global Setting** is checked. For example if you want to use a certain program (in Program mode) for the vocoder effect, you would uncheck **Use Global Setting** and make input settings individually for that program. The settings in Media mode are the same as the settings in Global mode.

### Routing

1. Access the Global P0: Basic Setup- Audio page.

*Note:* You must move to Global mode from the mode (other than Sampling mode) in which you want to input the external audio signals. If you move from Sampling mode to Global mode, the Audio Input settings of Sampling mode will be maintained, and you won't be able to view the settings of this page.

These settings are not used in Sampling mode. Audio input settings for Sampling mode are made in the Sampling P0: Recording- Audio In/Setup page.

⚠ When applying effects to the signals from the AUDIO INPUT 1, 2 and S/P DIF IN jacks, oscillation may occur depending on the effect type and parameter settings. If so, adjust the input level, output level, and effect parameters. In particular, use caution when using high-gain effects.

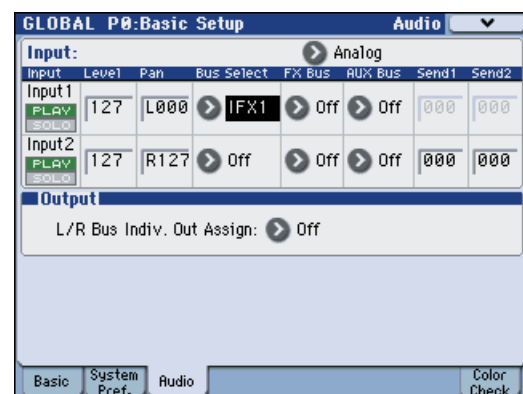

2. Use “Input” to select the input source, and set “Bus Select,” “Send 1,” and “Send 2” appropriately.

For details, please see “Routing of an external input” on page 158.

## Avoiding extraneous noise

⚠ If audio cables are connected to AUDIO INPUTS 1–2, any noise carried by the cables will enter into the M3 mixer structure. Similarly, the S/P DIF input may carry noise from external devices. This may include hiss, hum, and other audio noise.

To avoid noise from unused audio inputs, either:

- Set the input's **Level** to 0
- or
- Set all of the bus assignments to Off, including **Bus Select (IFX/Indiv. Out Assign)**, **AUX Bus**, and **FX Control Bus**

If no audio cables are connected to AUDIO INPUTS 1–2, the input signals are forced to zero, preventing any additional noise.

⚠ If you want to save the edited settings in the M3, you must write them. Use the Global mode menu command **Write Global Setting** to do this.

3. If you want to use the **Global mode Input settings in the other modes**, check the “**Use Global Setting**” option.

If you want to make independent settings for Programs, Combinations, and Songs, uncheck this setting.

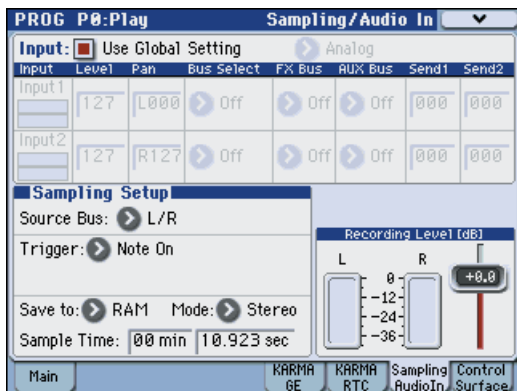



# Dynamic modulation, MIDI/Tempo Sync, and Common FX LFO

## Dynamic modulation (Dmod)

Dynamic modulation (Dmod) lets you use MIDI messages or the M3's controllers to modulate specific effect parameters in real-time.

For details, please see "Dynamic modulation (Dmod) and Tempo Synchronization" on page 422 of the Parameter Guide.

### Dmod Example

As an example, let's set up dynamic modulation to control an effect parameter in realtime.

1. As described in the procedure for "Program Effects settings" on page 155, set IFX1 to 064: L/C/R BPM Delay. Verify that you're hearing a delay effect.

2. Access the Prog P8: IFX- IFX1 page.

Using Dmod to change the delay level via the Joystick

3. Set Input Level Dmod to +100.

4. Set Source to JS+Y: #01.

The delay sound will disappear.

The input level to the effect can be controlled by the joystick. As you move the joystick away from yourself, the delay sound will gradually increase.

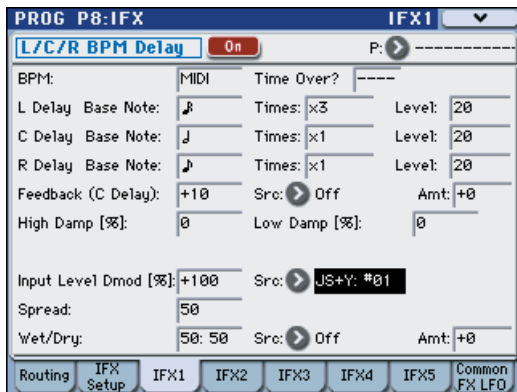

Using Dmod to change the feedback level via SW1

5. In the P1: Basic/DT/Ctrl- Controllers Setup page, set the SW1 function to SW1 Mod.CC#80, and the Mode to Toggle.

6. Choose P8. Set the Feedback Src to SW1: #80, and set Amt to +30.

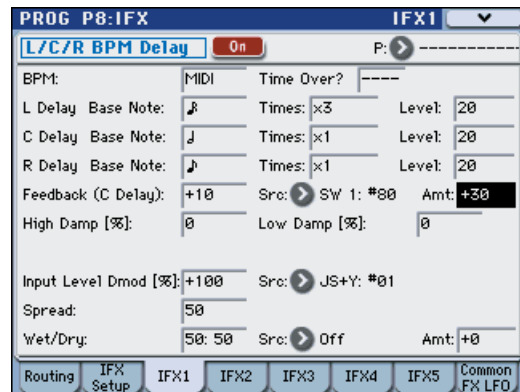

When you move the joystick away from yourself and press the SW1 switch, the feedback level will increase, and the delay sound will continue for a longer time. The Amt setting specifies the feedback level that will be in effect when the SW1 switch is pressed. If Amt is set to -10, pressing the SW1 switch will reduce the feedback level to 0.

## MIDI/Tempo Sync

MIDI/Tempo Sync lets you synchronize effects LFOs and delay times to the system tempo. For details, please see "Tempo Synchronization" on page 422 of the Parameter Guide.

Using the MIDI/Tempo Sync function to synchronize the delay time to KARMA tempo changes.

1. Set up the effects as described under "Dmod Example" on page 161.
2. Set BPM to MIDI.
3. For L, C, and R, set the Delay Base Note and Times as desired.

For this example, set Delay Base Note to ♩ and Times to x1 so that the effect will be easily understandable. The delay time will repeat at an interval of a 8th note.

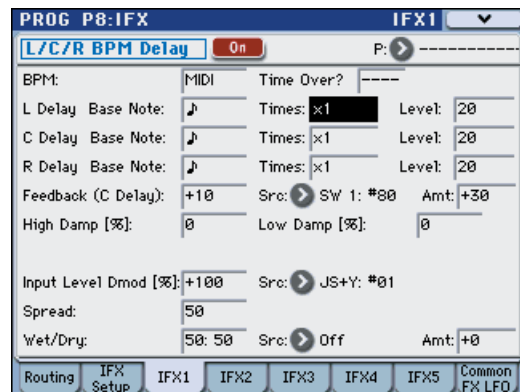



4. Rotate the TEMPO knob, and the delay time will change.

When you (push the joystick away from yourself and) press the SW switch, the feedback level will rise, and the delays will become longer.

**5. When you turn on the KARMA ON/OFF switch, KARMA will begin playing.**

Select any desired KARMA GE. When you rotate the TEMPO knob, the delay time will change in synchronization with the changing tempo of the KARMA.

 Depending on the specific delay effect, you may hear a noise if you change the tempo while the delay is sounding. This is because the delay sound becomes discontinuous, and is not a malfunction.

 For some effects, you can synchronize the LFO frequency to the tempo. Set the effect parameters **MIDI Sync** to On, and **BPM** to MIDI. For details, please see “Tempo Synchronization” on page 422 of the Parameter Guide.

## Common FX LFO

Two Common FX LFOs are available for modulation effects, such as choruses, filters, phasers, etc. In the P8–Common FX LFO page of Program, Combination, Sequencer, or Sampling modes, you can specify the reset conditions and speed of Common FX LFO 1 and 2.

Normally, the LFOs of two or more modulation-type effects used simultaneously will not have synchronized phase even if you set them to the identical Frequency, since the LFOs are being generated independently.

However if you select Common 1 or Common 2 for the **LFO Type** parameter of a modulation-type effect, the effect will use not its own individual LFO but the Common LFO you specify here. This allows you to use a single Common FX LFO to simultaneously control two or more modulation-type effects such as flanger, phaser, or auto-pan with the same phase. Since you can make independent settings for LFO waveform and phase offset for each effect, you are free to create complex combinations of effects.

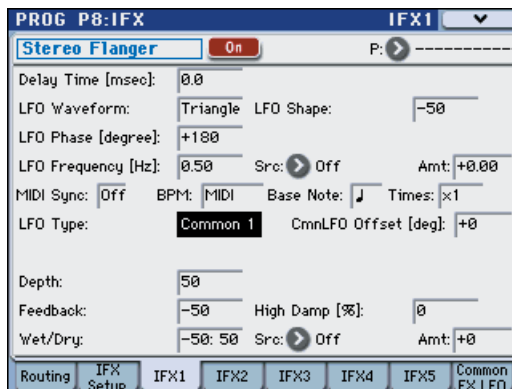
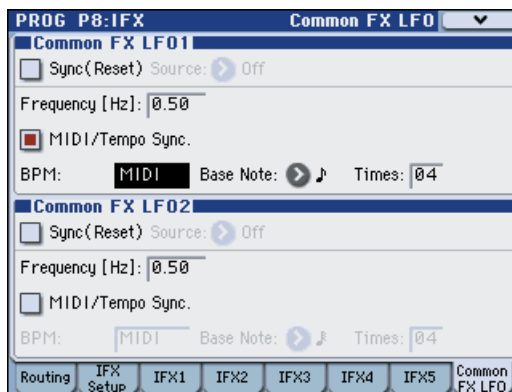
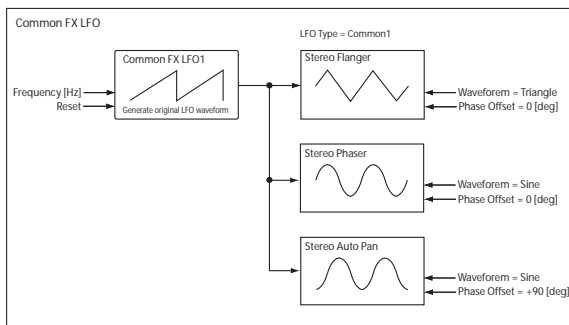

# Using KARMA

## Overview

### What is KARMA?

KARMA stands for Kay Algorithmic Realtime Music Architecture, named after its inventor, Stephen Kay. The KARMA function generates MIDI data, using many different algorithms seamlessly integrated to provide a powerful “music generation engine.” Based on the notes and chords you play, KARMA generates phrases and patterns in real-time, generating not just notes but MIDI control data as well. The KARMA architecture allows the various algorithms to be reconfigured and varied in realtime, as you play them. For example, you can create the dynamic tempo changes that occur within a harp glissando, the synchronized changes in volume and tone that occur as part of a brass phrase, the randomness within a drum phrase, the crescendo and diminuendo of a fill-in, changes in phrase or tone of a techno groove, complex interweaving phrases that would be impossible to play on a keyboard, guitar strumming and finger-picking simulations with natural-sounding changes, and backing grooves that follow your keyboard playing in realtime – all under your control. KARMA lets you produce phrases and patterns at a far more musical and flexible level than conventional arpeggiators or pattern playback functions. On the M3, the KARMA function is designed to work in close conjunction with the numerous other functions, giving you unbelievable performance power on stage or in the studio.

### The structure of the KARMA function

The KARMA function consists of the following major parts.

#### KARMA modules

A KARMA module uses a GE to generate phrases or patterns.

In Program mode, only one KARMA module (A) is used.

In Combination or Sequencer modes, four KARMA modules (A, B, C, D) can be used. For example, each module might be used to generate phrases and patterns for a separate sound, such as drums, bass, guitar, and piano.

**MIDI** In Program mode, the KARMA module transmits and receives all MIDI data on the Global MIDI channel specified by **MIDI Channel**.

In Combination and Sequencer modes, the MIDI data from each KARMA module is transmitted and received on the **In (Input Channel)** and **Out (Output Channel)** specified for each module.

#### GE (Generated Effect)

The phrases and patterns produced by a KARMA module are generated by the GE.

Note data from the keyboard will affect how note data will be developed; and how rhythm, chord structure, and velocity etc. will be controlled to generate a phrase or pattern. MIDI control changes and pitch bend data can also be generated in synchronization with the phrase or pattern. As a capability unique to the M3, the KARMA function can generate MIDI exclusive messages to control wave sequencing, which switches between multisamples etc. of a program in realtime. This lets you create phrases and patterns in which the tone color and note pitches change independently.

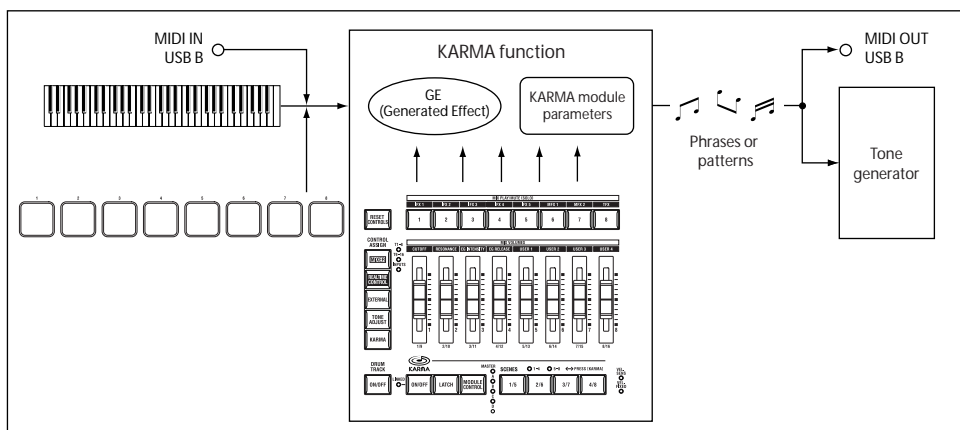

The M3 provides a large number of GEs that can be used for a variety of instruments, performance techniques, and musical styles.

**GE RTP – Real Time Parameters**

A GE consists of over two hundred internal parameters.

In each GE, up to 32 of these internal parameters are pre-selected as the most suitable parameters for use in

controlling the phrase or pattern. These parameters are called the “GE realtime parameters.”

You can control the phrase or pattern by editing these parameters, or by assigning them to the KARMA sliders or KARMA switches and operating these during your performance.

KARMA - Program mode

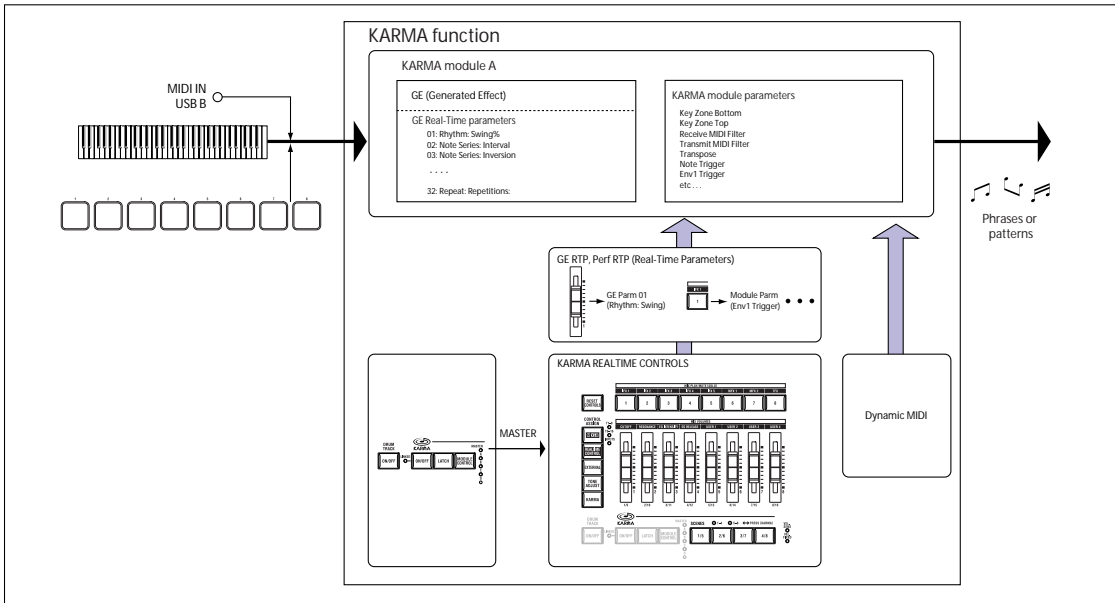

KARMA - Combination/ Sequencer mode

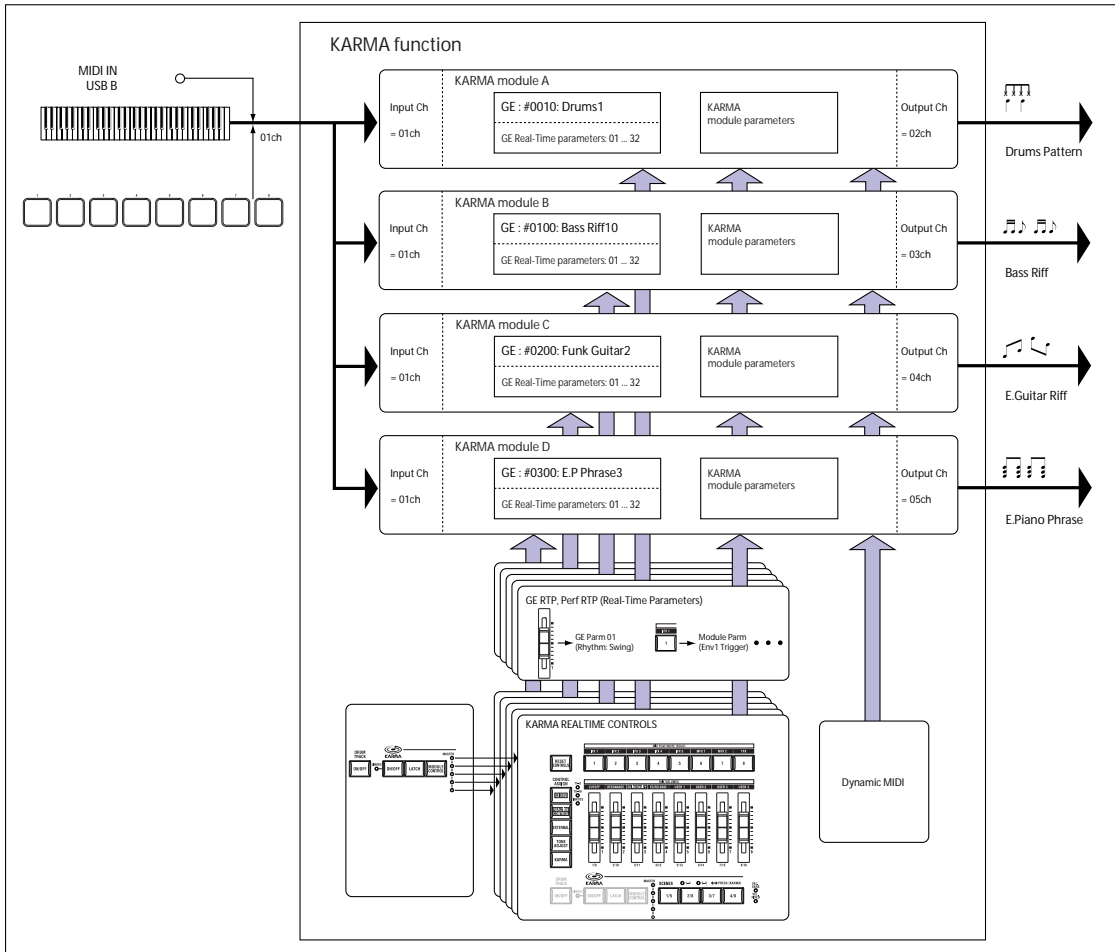

### \* RTC Model

All of the preset GEs have an internally-specified RTC Model. The RTC Model is a certain standardization of the more than two hundred internal parameters of the GE, based on the type and purpose of that GE.

GEs for which the same RTC Model has been specified will (by default) have the same parameters assigned as their GE realtime parameters. This means that even if you're switching through various GEs that have the same RTC Model, you will be able to control them in a uniform manner and make valid comparisons between them, since their default state will be the same. Of course, you are free to edit the GE realtime parameters.

In the pre-loaded programs and combinations, the KARMA sliders and KARMA switches are assigned in a uniform manner depending on the RTC Model for the GE used by each module. For example if a KARMA module used by a program or combination uses a GE of the Drum/Percussion category, the KARMA sliders and KARMA switches will be assigned so that Slider 1 controls the swing and Slider 2 controls the pattern variation. Of course, you are also free to edit the KARMA sliders and KARMA switches assignments.

Each GE is assigned one of the following RTC Models.

- DP1 - Drum/Perc
- BL1 - Bass/Lead
- DM1 - Drum Melodic
- GV1 - Gated Vel/Pattern
- GC1 - Gated CCs
- CL1 - Comp/Lead
- WS1 - WaveSeq 1
- WS2 - WaveSeq 2
- EG1 - Dual Env Gen
- LF1 - Dual LFOs
- MR1 - Melodic Repeat
- MB1 - Mel Rpt/Bend
- RB1 - Real-Time Bend
- Custom - a few GEs may require special RTC setups, outside of the normal RTC Models. In this case, the assignment of RTC Controls is left up to the sound designer of the specific Program or Combination.

An example is 2028: VJS Motion. If you load this GE, it clears all RTC Model assignments (when the GE Load Options are set to the default setting). With such GEs, it's generally best to copy the Module from an existing Program, so that you have an example of how to map the controls.

### \* Auto RTC Setup

This is a convenient function that automatically makes KARMA sliders and KARMA switches assignments according to the RTC Model setting of a GE. Use the Load GE Options dialog box to make these settings automatically. Here you can choose whether you want KARMA controller assignments to be made automatically when you use the GE Select parameter to select a GE. If you've chosen **Auto RTC Setup** in this dialog box, the assignments will be made automatically each time you change the GE. This means that regardless of the type of GE that's selected,

you will immediately be able to use the standard KARMA CONTROL assignments. (See PG page 4)

### KARMA module parameters

These are the parameters that control the phrases and patterns generated by a KARMA module.

You can set these parameters independently for each KARMA module. These parameters include the GE selection, MIDI input/output channel, key zone, MIDI filtering, and triggering.

### GE RTP (GE Real-Time Parameters) Perf RTP (Perf Real-Time Parameters)

These are the parameters that you can control via the KARMA sliders or KARMA switches.

If GE realtime parameters (GE RTP) and KARMA module parameters (Perf RTP) are assigned to the KARMA sliders and KARMA switches, you'll be able to control them in realtime to modify the phrase or pattern while you play.

### Dynamic MIDI

Dynamic MIDI is a function that uses the M3's controllers or MIDI control messages to control specific functions of the KARMA function.

For example, this enables you to use the joystick to play strummed guitar chords, use a foot switch to control the Run/Mute status of a KARMA module, or use the damper pedal to latch a KARMA module. You'll be able to control them in realtime while you play.



## KARMA CONTROLS

These are front panel controls used to control the KARMA function. The settings of these controls can be saved independently for each Program, Combination, and Song (see page 140, and page 142).

### ON/OFF switch

This switches the KARMA function on/off.

### LATCH switch

If this is on, the phrase or pattern will continue playing even after you remove your hand from the keyboard or pads 1–8.

### MODULE CONTROL switch

In Combination or Sequencer mode, this selects the module that will be controlled by the KARMA sliders 1–8, KARMA switch (SWITCHES) 1–8, and KARMA SCENE 1–8 switches.

**MASTER:** Choose this setting if you want to control modules A, B, C, and D simultaneously. For example, this lets you use KARMA slider 1 to control the GE realtime parameter Swing for all modules A, B, C, and D.

**A, B, C, D:** Choose one of these settings if you want to control the corresponding module individually.

*Note:* In Program mode only MASTER can be selected, and module A will be controlled.

### KARMA Slider 1–8 (SLIDERS 1–8) KARMA Switch 1–8 (SWITCHES 1–8)

When CONTROL ASSIGN is set to KARMA, these control the KARMA module(s) selected by MODULE CONTROL.

By operating these controls, you can adjust GE realtime parameters and KARMA module parameters to freely vary the phrases or patterns generated by the KARMA module. (Use “P7: KARMA–GE RTP page, Perf RTP” to specify the parameter that each control will affect.)

### KARMA SCENE 1–8

These switches let you store the settings of sliders 1–8 and KARMA switches 1–8 as eight different “scenes” (KARMA SCENE 1–8). In Combination or Sequencer modes, scenes can store separate settings for each

module, and you can use the MODULE CONTROL switch and the Scene Matrix function to control this.

For details, please see “7–1–7a: Module Control Scene Matrix” on page 165 of the Parameter Guide.

### PAD MODE switch

This selects either VEL. SENS (velocity sensitive) in which the force at which you strike a pad will affect the loudness of the sound, or VEL. FIXED (velocity fixed) in which the fixed velocity value you specify in the Pads 1–4/5–8 Setup page will always be used.

### CHORD ASSIGN switch

Use this to assign individual notes or multiple notes such as chords to each pad 1–8 (See page 44).

### Pads 1–8

Pads 1–8 are velocity-sensitive pads that respond to the force with which you press them. When you press a pad, the assign note or chord (up to eight notes with a velocity setting) will play. You can use the pads in many ways, such as using them to play drum sounds, to trigger sampled sounds, or as chord pads to trigger the KARMA function.

In the pre-loaded programs and combinations, the pads are assigned effective chords. You can use the CHORD ASSIGN switch to easily assign your own chords.

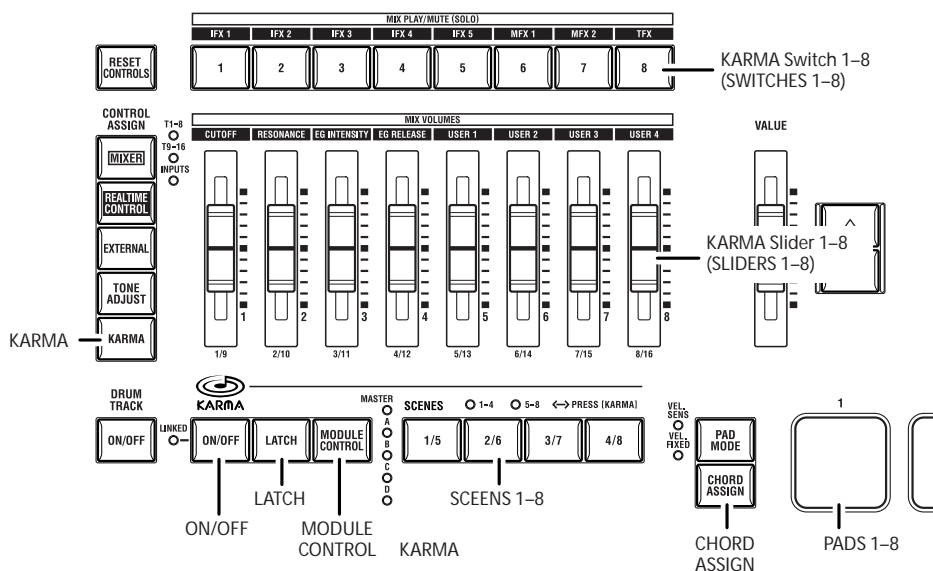

# Performing with KARMA

Based on your keyboard playing or on the note data received from MIDI IN, USB B, the KARMA function automatically generates a diverse variety of phrases or patterns, such as guitar or keyboard backing riffs, bass phrases, or drum patterns. You can use the KARMA sliders and the KARMA switches to freely modify these phrases or patterns.

The M3 contains pre-loaded programs and combinations that take full advantage of the KARMA function, covering a wide range of instruments, playing techniques, and musical genres. In these programs and combinations, the parameters most useful for controlling the KARMA function have been assigned to the KARMA sliders and KARMA switches.

## Performing with KARMA in Program mode

In Program mode you can use one KARMA module to generate a phrase or pattern appropriate for the sound of the program.

### Selecting a Program and switching KARMA on/off

1. Press the MODE PROG switch to enter Program mode, and select the desired program. (See “Selecting Programs” on page 37)



As you step through the programs, you'll find some programs for which the KARMA ON/OFF switch LED is lit.

Press a key or a pad 1–8, and the KARMA function will begin playing.

In other programs as well, you can press the ON/OFF switch (the LED will light) to turn the KARMA function on.

*Note:* If the Drum Track function is on (when **Trigger Mode** is set to Wait KBD Trig), the drum track will start playing simultaneously.

### Adjusting the performance tempo

1. You can use the TEMPO knob or the TAP TEMPO switch to adjust the performance tempo.

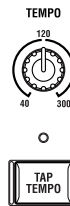

This will change the “♩=” value located in the upper right of the display. You can adjust the tempo in a range of 40.00–300.00. The LED located above the TAP TEMPO switch will blink at intervals of a quarter note (♩).

As an alternative to using the TEMPO knob or the TAP TEMPO switch, you can choose “♩=” in the display, use numeric keys 0–9 to enter the tempo, and then press the ENTER switch. You can also use the VALUE controller to set the tempo. The LED will blink at the tempo you specify.

*Note:* The setting of the TEMPO knob is also saved when you write a program.

- ⚠ If the Global P1: MIDI- MIDI Basic page MIDI Clock parameter is set to External MIDI, External USB, or set to Auto and MIDI Clock messages are being received, the display will indicate “♩=” EXT, and the M3 will be synchronized to an external MIDI device. In this case, you won't be able to change the tempo by operating the M3.

### Checking note-on/off and key zone

The screenshot shown below is a realtime display of the note data received from the keyboard, pads 1–8, MIDI IN, or USB B, and the note on/off data generated by the KARMA module, together with the name of the chord that was detected.

1. Access the Prog P0: Play- KARMA RTC page.

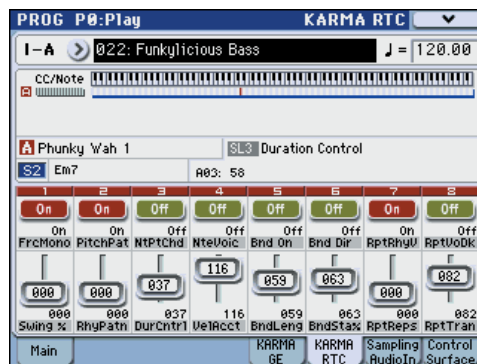

When you play the keyboard or strike a pad 1–8, the name of the chord detected by the KARMA module will appear in the “Chord” field of KARMA Module Info.

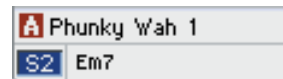

The CC/Notes area shows the key zone of the KARMA module, and the state of the control data and note on/off data generated by the KARMA module. (See “Specifying the keyboard zone for the KARMA function” on page 172)



KARMA

## Using the KARMA controllers

*Note:* The state of the KARMA controllers is saved when you write the program.

### KARMA function on/off: ON/OFF switch

The KARMA function will turn on/off each time you press the ON/OFF switch. If it is on, the switch LED will light. When you play the keyboard or pads 1–8, the GE selected for the KARMA module will start generating a phrase or pattern.

### Using the pads: pads 1–8

When you press a pad 1–8, the assigned chord (up to eight notes with a velocity setting) will play, and the KARMA function will start generating a phrase or pattern. Effective chords are already assigned for the pre-loaded programs. You can play the pads together with the keyboard.

For details on how to assign chords to the pads, please see “Drum & Chord Pads” on page 44.

### Making the performance continue after you remove your hand from the keyboard or pads 1–8: LATCH switch

You can make the KARMA function continue playing even after you remove your hand from the keyboard or pads 1–8.

LED lit: Latch is on. The performance will continue even after you remove your hand from the keyboard or pads 1–8.

LED dark: Latch is off. The performance will stop when you remove your hand from the keyboard or pads 1–8.

### Modifying the phrase or pattern generated by the KARMA module: KARMA sliders 1–8, KARMA switches 1–8, KARMA SCENE 1–8 switches

Parameters useful for controlling the phrase or pattern are already assigned to the KARMA sliders 1–8 and KARMA switches 1–8, and KARMA SCENE 1–8 switches. You can operate these controllers to create a wide range of changes in the phrase or pattern that’s playing.

#### 1. Access the Prog P0: Play– KARMA RTC page.

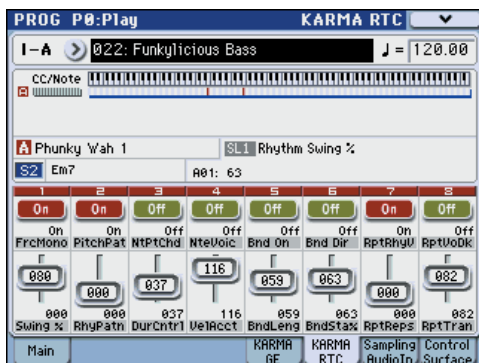

The lower part of the display shows the names of the sliders and switches that are assigned in this program. In the pre-loaded programs, the KARMA sliders and KARMA switches have already been assigned.

#### 2. Press the CONTROL ASSIGN KARMA switch.

Sliders 1–8 and switches 1–8 of the control surface will operate as KARMA sliders and KARMA switches.

#### 3. Operate the front panel sliders 1–8 and switches 1–8.

The pattern or phrase will change accordingly.

You can also turn the switches on/off by pressing them in the display. You can operate the sliders by selecting them and then using the VALUE controller to adjust the value.

The type or value of the parameter being controlled by the sliders and switches is shown in the KARMA Module Info “KARMA Value” field. This lets you see how the parameters are being affected by your slider or switch operations.

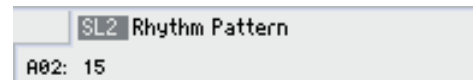

The saved value is shown at the lower right of each slider or switch.

#### 4. Use the front panel KARMA SCENE 1/5–4/8 switches to choose a scene.

While the CONTROL ASSIGN KARMA switch is on, pressing the KARMA switch once again will make the 1–4 or 5–8 LED blink to indicate the next candidates for selection. When you then press a 1/5–4/8 switch, the corresponding KARMA scene will be selected.

When you switch scenes, the sliders and switches will change to the settings saved in the selected scene.

*Note:* If you press the CONTROL ASSIGN KARMA switch while either the 1–4 or 5–8 LED is still blinking, the LED will stop blinking and the previous scene group (1–4, 5–8) will still be selected.

Each of the eight scenes contains the values of sliders 1–8 and switches 1–8. By pressing one of the KARMA SCENE 1/5–4/8 switches (and the CONTROL ASSIGN KARMA switch) to choose a scene, you can instantly recall settings for the eight sliders and eight switches.

Even if you switch scenes, the changes you make using sliders 1–8 and switches 1–8 are remembered until you select another program. When you write a program, your slider and switch settings are saved in the respective scene 1–8.

### Restoring the state of the sliders and switches

You can use the following methods to restore modified settings to their prior state. For details, see the corresponding reference page.

- Press the COMPARE switch to revert the settings of the entire program. (See “COMPARE switch” on page 23)
- Use the RESET CONTROLS switch to reset the settings. You can reset the following units of settings.
  - An individual slider or switch, one scene, one module control, or all. (See “Resetting controls to their saved values” on page 43)
  - (See “Resetting controller values” on page 199)

⚠ If you use the RESET CONTROLS switch to reset the settings, there’s no way to return to the state prior to this reset.



*Note:* If the KARMA SCENES switch is blinking, this indicates that the KARMA display and KARMA slider settings of that scene have been edited from their saved state.

### Selecting a GE (Generated Effect)

When the KARMA function is on, the KARMA module uses a GE to generate phrases or patterns. The M3 provides a wide range of GEs that you can use for a variety of instruments, playing techniques, and musical styles (See “The structure of the KARMA function” on page 163).

For each of the pre-loaded programs, a GE that’s appropriate for the sound of the program is already selected. If you switch to a different GE, the generated phrase or pattern will change dramatically.

#### 1. Access the Prog P0: Play– KARMA GE page.

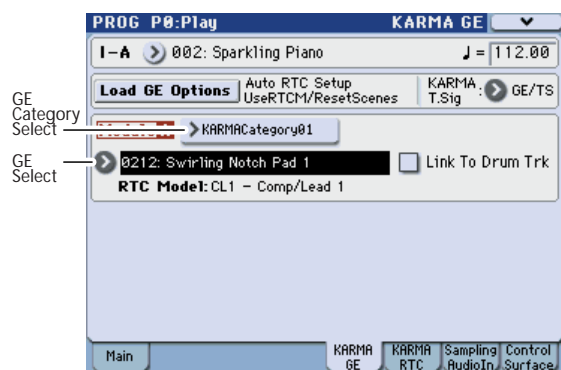

#### 2. In the display, press the “GE Category Select” popup button to access the “GE Select” menu.

#### 3. Select a category from the left and right tabs, and select a GE from the menu.

The selected GE will be highlighted and will become active.

If you now play the keyboard, this GE will generate a phrase or pattern.

While this menu is displayed, you can select and play these GEs without pressing the OK button.

#### 4. If you are satisfied with the program you selected, press the OK button to close the menu.

Alternatively, you can select a GE by choosing “GE Select” in the display, and operating the VALUE slider or VALUE dial. Alternatively, you can press the “GE Select” popup button, and select a GE from the “GE Select” menu.

#### 5. Use “Tempo” to set the tempo of the pattern or phrase generated by the GE.

Use **KARMA T.Sig** to specify the time signature of the GE phrase or pattern. If you set this to GE/TS, the time signature specified by the GE will be used. With any other setting, the time signature will be changed temporarily.

### Editing KARMA module parameters

For details on editing the parameters of a KARMA module, please see “KARMA function settings” on page 172.

## Performing with the KARMA function in Combination mode

In Combination mode, up to four KARMA modules can be operating simultaneously. You can use the four KARMA modules together with the sixteen timbre programs in a wide variety of ways, for example by using them to independently play phrases and patterns for separate programs such as drums, bass, guitar, and strings.

### Selecting a combination and turning the KARMA function on/off

1. Press the **MODE COMBI** switch to enter Combination mode, and select the desired combination. (See “Selecting Combinations” on page 65)

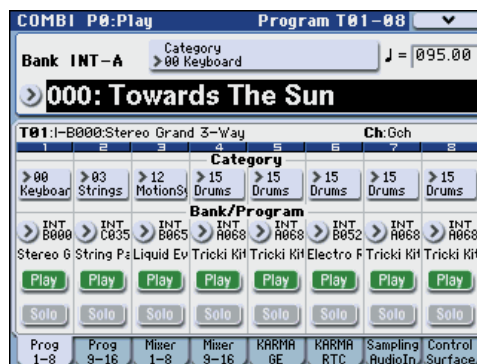

As you step through the combinations, you will notice that the KARMA ON/OFF switch LED is lit for some combinations.

With these combinations, the KARMA function will begin playing when you play the keyboard or pads 1–8.

*Note:* If the Drum Track function is on (when **Trigger Mode** is set to Wait KBD Trig), the drum track will start playing simultaneously.

Even for other combinations, you can press the KARMA ON/OFF switch (the LED will light) to turn on the KARMA function.

### Adjusting the performance tempo

In the same way as for a program, you can use the **TEMPO** knob or the **TAP TEMPO** switch to adjust the performance tempo. Changing the tempo will affect the tempo of all KARMA modules that are operating. (See page 167)

 You can’t adjust the performance tempo of each KARMA module individually.



## Checking note-on/off and key zone

The screenshot shown below is a realtime display of the note data received from the keyboard, pads 1–8, and MIDI IN or USB B, and the note on/off data generated by KARMA modules A, B, C, and D, together with the name of the chord that was detected.

### 1. Access the Combi P0: Play– KARMA RTC page.

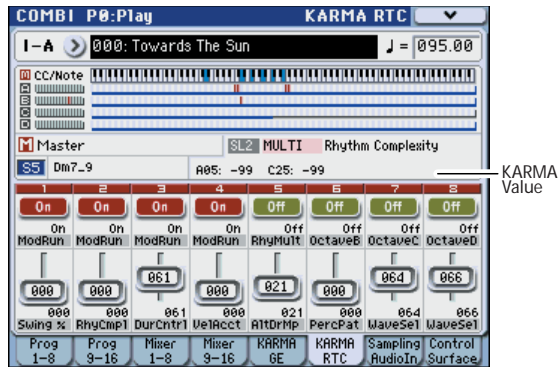

When you play the keyboard or strike a pad 1–8, the name of the chord detected by each KARMA module will appear in the “Chord” field of KARMA Module Info.

The displayed chord name is the chord that is detected by the module selected by the front panel MODULE CONTROL switch. The way in which chords are detected will depend on the settings of the KARMA module.

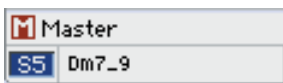

The CC/Notes area shows the status of the control data and note-on/off data generated by KARMA modules A, B, C, and D, and the key zone settings of the KARMA modules.

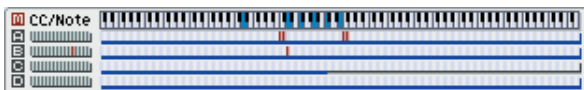

*Note:* Chord detection is affected by the KARMA module’s key zone settings (see “7–1–1b: GE Setup” on page 161 of the Parameter Guide), **Transpose** (see “7–2–1a: Module Parameter-Control” on page 169 of the Parameter Guide), and Dynamic MIDI **Destination** (Combi 7–4–2) Chord Scan and Smart Scan. (See PG page 604)

## Using the KARMA controllers

You can operate the KARMA controllers to control the phrase or pattern generated by each KARMA module. In Combination mode, you can choose the KARMA module that you want to control.

*Note:* The state of the KARMA controllers is saved when you write the combination.

### 1. Access the Combi P0: Play– KARMA RTC page.

The lower part of the display shows the names of the sliders and switches that are assigned in this combination.

In the pre-loaded combinations, the KARMA sliders and KARMA switches have already been assigned.

### 2. Press the CONTROL ASSIGN KARMA switch.

Sliders 1–8 and switches 1–8 of the control surface will operate as KARMA sliders and KARMA switches.

### 3. Use the front panel MODULE CONTROL switch to select the module that you want to control.

If you select MASTER, you will be controlling all four KARMA modules simultaneously.

If you select A–D, you will be controlling the corresponding KARMA module.

### 4. Operate the front panel KARMA sliders 1–8 and KARMA switches 1–8.

The sliders and switches will control the pattern or phrase generated by the KARMA module selected by the MODULE CONTROL switch. If you’ve selected MASTER, you’ll be able to control the module on/off status and vary the patterns and phrases generated by all of the KARMA modules.

You can also operate the sliders and switches in the display or using the VALUE controller, just as in Program mode.

The KARMA module and the type or value of the parameter being controlled by the sliders and switches is shown in the KARMA Module Info “KARMA Value” field. This lets you see the KARMA module and parameters that are being affected by your slider or switch operations.

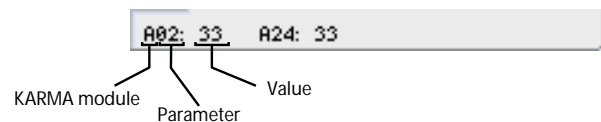

### 5. Use the front panel KARMA SCENE 1/5–4/8 switches to choose a scene.

When you press the CONTROL ASSIGN KARMA switch, the 1–4 or 5–8 LED will light to indicate the candidates for the next selection. Then when you press the 1/5–4/8 switch, the corresponding KARMA scene will be selected.

When you switch scenes, the scene will change for the KARMA module selected by the MODULE CONTROL switch.

If Module Control is set to MASTER, each KARMA module will change to the scene that is saved as the master setting.

Each of the eight scenes contains the values of KARMA sliders and KARMA switches. By pressing one of the KARMA SCENE 1/5–4/8 switches (and the CONTROL ASSIGN KARMA switch) to choose a scene, you can instantly recall settings for the eight sliders and eight switches.

Even if you switch scenes, the changes you make using KARMA sliders 1–8 and KARMA switches 1–8 are remembered until you select another combination. When you write a combination, your slider and switch settings are saved in the respective scene 1–8.

## Name display for the KARMA sliders 1–8 and KARMA switches 1–8

Just as in the equivalent page of Program mode, the Combi P0: Play– KARMA RTC page displays the sliders and switches assigned to the combination, and their names.

In the combination, the name shown in square brackets [ ] is the category of the program selected for the



timbre being controlled by the KARMA sliders 1–8 and KARMA switches. This tells you the timbre whose phrase is being controlled by the KARMA sliders 1–8 and KARMA switches.

If multiple timbres are being controlled simultaneously, this will indicate **MULTI**.

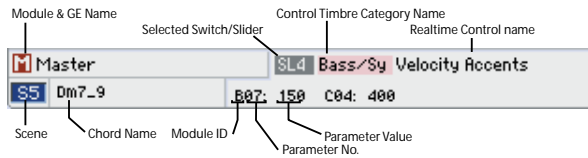

### KARMA module “Run” and “Solo” settings

In Combination mode, up to four KARMA modules can be operating simultaneously.

If the KARMA function is off, all KARMA modules will be stopped. If the KARMA function is on, the KARMA module(s) you specify here will operate.

1. Access the Combi P7-1: KARMA1- GE Setup A page.

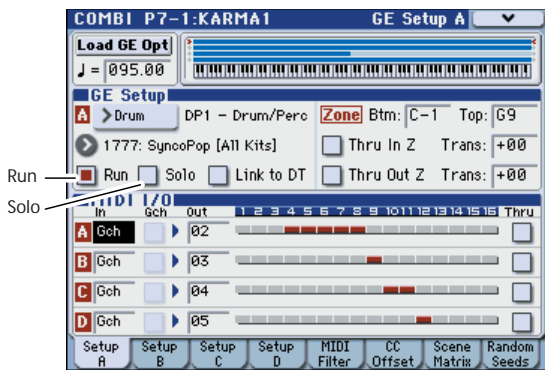

2. Use “Run” and “Solo” to specify whether KARMA module A will sound when KARMA is on.

KARMA modules whose **Run** setting is On (checked) will operate.

If you turn **Solo** On (checked), only that KARMA module will sound. This is useful when you are selecting a GE, or when you want to audition the phrase that a module is generating.

Modules whose **Solo** is On (checked) will sound even if **Run** is Off (unchecked).

*Note:* If **Run** is not shown in the display, it has been assigned as a performance realtime parameter. Use a KARMA switch etc. to control the **Run** parameter. (See “Perf RTP (Perf Real-Time Parameters)” on page 179)

The **Solo** setting is cleared when you switch to another combination. It is not saved when you write the combination.

3. Use the Combi P7-1: KARMA1- GE Setup B, C, and D pages to set the “Run” and “Solo” settings for KARMA modules B, C, and D.

### KARMA module MIDI I/O channel settings

The MIDI input/output channel setting for each KARMA module and the MIDI channel setting of each timbre together determine how the KARMA modules will play the timbres.

Use the Combi P7-1: KARMA1- GE Setup A, B, C, and D pages to set the MIDI I/O. If a KARMA module’s MIDI output channel matches the MIDI channel of a timbre, the phrase or pattern generated by that KARMA module (if it’s operating) will play that timbre. For details on making these settings, please see “KARMA function settings in Combination mode” on page 176. See “7-1-1c: MIDI I/O” on page 162 of the Parameter Guide.

### GE (Generated Effect) selection

Just as for a program, you can use the “GE Select” field to select the GE used by each module. (See “KARMA function settings in Combination mode” on page 176)

When you’ve selected a GE, use **Tempo** to specify the tempo of the GE’s phrase or pattern.

Use **KARMA T.Sig** to specify the time signature of the pattern or phrase generated by the GE. If you select GE/TS the time signature specified by the GE for each module will be used; with any other setting, the time signature of all GEs will change temporarily.

### KARMA module parameter settings

For details on editing KARMA module parameters, please see “KARMA function settings in Combination mode” on page 176.

## KARMA function settings

This section explains how to make settings for the KARMA function in each mode. For details on how to perform using the KARMA function, please see “Performing with KARMA” on page 167.

### KARMA function settings in Program mode

In Program mode you can use only one KARMA module (module A). KARMA function settings for a program are made in the various pages of Prog P7: KARMA. Here we will explain how to use the major parameters, such as selecting a GE. For other parameters, please see “PROG P7: KARMA” on page 77 of the Parameter Guide.

#### Switching the KARMA function on/off

Each time you press the KARMA ON/OFF switch, the KARMA function will be turned on or off. When on, the switch LED will be lit.

The on/off status is saved when you write the program.

#### Selecting a GE

Here’s how to select the GE used by the KARMA module.

##### 1. Access the Prog P7-1: KARMA1- GE Setup page.

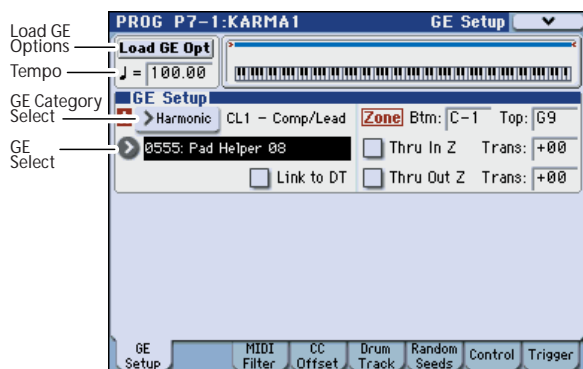

##### 2. Press “Load GE Opt” (Load GE Options) to access the dialog box, turn Auto RTC Setup on, and check the User RTC Model and Reset Scenes options.

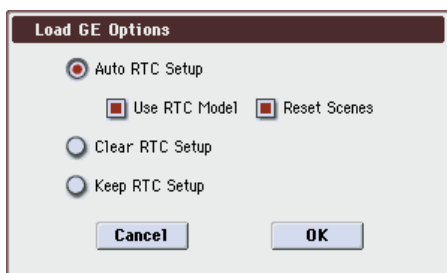

“Load GE Options” specifies whether the settings of the KARMA sliders and KARMA switches settings will be automatically set, initialized, or maintained when you select a GE.

In this example, we’ve opted to automatically set the slider and switch functions to the standard settings for the RTC Model of the selected GE, so that you’ll be able to control the phrase or pattern immediately.

##### 3. Use “GE Select” to select the GE used by the KARMA module.

Use **Tempo** to set the tempo of the pattern or phrase generated by the GE.

The M3 provides numerous preset GEs that can be used for a wide range of instruments, playing techniques, and musical styles.

“GE Category Select” shows the category of the GE that’s selected for the KARMA module. All GEs are organized by category. You can press “GE Category Select” to open the Category/GE Select page, and choose a GE by category and sub-category (see “GE Category Select” on page 5 of the Parameter Guide).

#### Copying KARMA function settings from another program

You can use the **Copy KARMA Module** menu command to copy the KARMA function settings (EG selection, KARMA module parameter settings, etc.) from another program.

##### 1. Press the menu button to open the menu, and choose “Copy KARMA Module.”

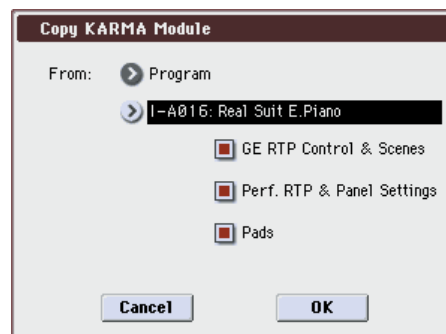

##### 2. Specify the copy-source mode, bank, and number.

If you want to copy the GE realtime parameter settings and scene settings from the copy-source program, choose the “GE RTP Control & Scenes” option (checked).

If you want to copy performance realtime parameters settings and front panel settings from the copy-source program, choose the “Perf. RTP & Panel Settings” option (checked).

If you to copy the pad settings from the copy-source program, choose the “Pads” option (checked).

##### 3. Press OK to execute the copy, or press Cancel if you decide to cancel.

#### Specifying the keyboard zone for the KARMA function

Here’s how to specify the zone of keys that will trigger the KARMA function. For example you might make settings so that the keys at the bottom of the keyboard will trigger phrases, and keys above this range can be played normally.

1. Access the Prog P7-1: KARMA1- GE Setup page. (See the diagram in step 1 of “Selecting a GE”)
2. Use the Key Zones “Btm” (Bottom) and “Top” to specify the key zone.

Keys you press and note data received from MIDI IN, USB B that falls within this range will be sent to the KARMA module.

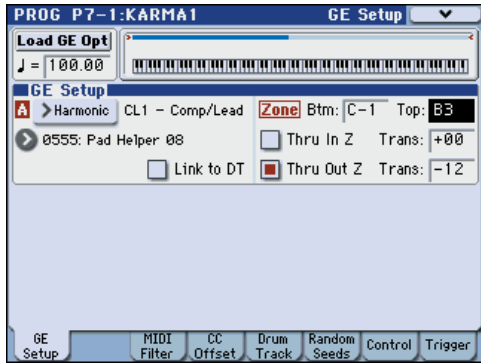

In the example shown above, the notes from C-1 through B3 are being input to the KARMA module. When you play B3 or a lower note, the KARMA function will generate a phrase or pattern.

3. If “Thru In Z (Zone)” and “Thru Out Z (Zone)” are on (checked), the notes you play on the keyboard will play in addition to the phrase or pattern generated by the KARMA function.

These two fields are the settings for inside and outside the key zone.

You can use “Trans (Transpose In Zone)” and “Trans (Transpose Out Zone)” to transpose the notes played on the keyboard in semitone steps.

In the example shown above, the B3 and lower keys will control only the phrase or pattern generated by the KARMA function, and the C4 and higher keys will be used for manual playing on the keyboard. Use “Trans (Transpose Out Zone)” to adjust the pitch of the manually-played region.

### KARMA module MIDI filtering

1. Access the Prog P7-1: KARMA1- MIDI Filter page.

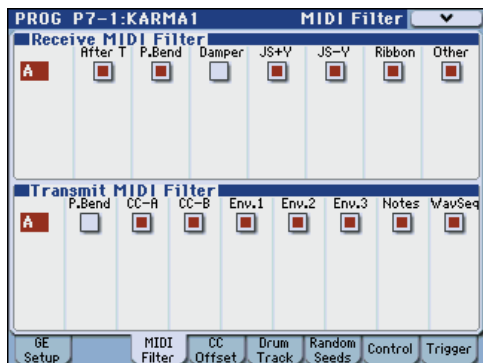

#### Receive MIDI Filter

This specifies whether filtering will be applied to the MIDI control data received by the KARMA module. If an item is on (checked), the corresponding data will be received.

When the KARMA function is on, MIDI control data received by the KARMA module is sent directly to the tone generator. If this setting is off (unchecked), that data will not be sent to the tone generator.

In the example shown above, damper pedal messages are enabled when the KARMA function is off, and disabled when it is on.

#### Transmit MIDI filter

This specifies whether filtering will be applied to the MIDI control data generated by the GE selected for the KARMA module. If an item is on (checked), transmission is enabled.

Normally you will leave these items on. If you don't want to use the pitch bend or other control change data generated by the selected GE, turn these items off (unchecked).

In the example shown above, pitch bend data generated by the GE will not be transmitted.

### KARMA module CC offset

1. Access the Prog P7-1: KARMA1- CC Offset page.

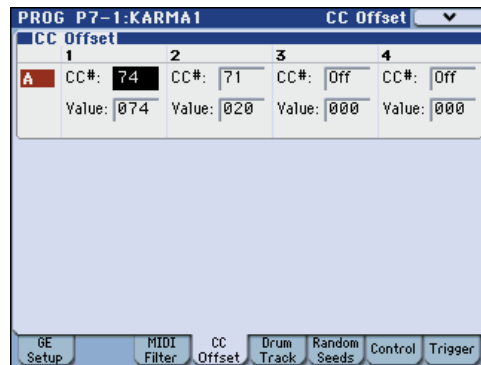

#### CC Offset

Use this if you want to control the effects or the sound of the program while the KARMA function is on. For example, you might use this to decrease the brightness of the sound or raise the resonance of the sound in conjunction with the phrase that's being generated. Alternatively, you might use this to control effects, for example by turning on a delay effect in conjunction with a generated phrase.

Use “CC Number” to specify the MIDI control change number. Choose one of the CC numbers in the 70's which control the sound, or an AMS or Dmod source (see “7-1-4a: CC Offset” on page 80 of the Parameter Guide).

In the example shown in the preceding page, CC#74 and CC#71 are controlling filter cutoff and resonance level.

### KARMA module parameters

In the Prog P7-1: KARMA1- Control and Trigger pages you can edit KARMA module parameters.

Here we will describe how to edit the most frequently-used parameters. For details on the other parameters, please see “7-1-7: Control” on page 84 of the Parameter Guide.

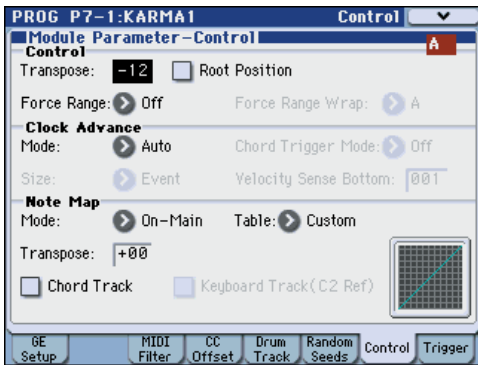

**Control – Transpose**

This lets you transpose the note data being input to the KARMA module in semitone steps. This will control the pitch of the phrase or pattern generated by the KARMA module. For example if you want to lower a bass phrase by one octave, set this to -12.

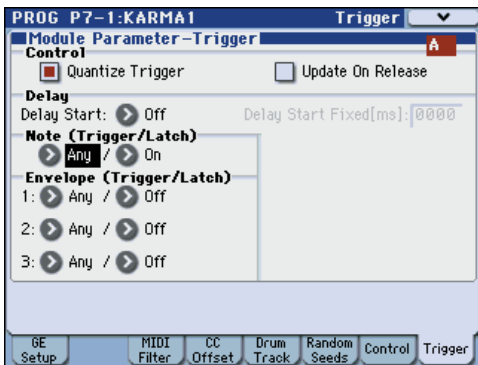

**Control – Quantize Trigger**

This quantizes the timing of the triggering produced by the note data. (See “Synchronizing the KARMA function” on page 182)

**Off (unchecked):** Triggering will occur the moment you play the key.

**On (checked):** Trigger timing will be quantized to 16th note intervals relative to the base tempo.

**Note – Trigger**

This specifies the triggering conditions for the phrase or pattern generated by the GE. Try these out and see how they differ.

**Any:** Triggering will occur each time you play a key, and the phrase or pattern will play from the beginning.

**AKR:** Triggering will occur only the first time you play a key after having released all notes on the keyboard.

**1st:** Triggering will occur only at the first note you play after turning on the KARMA function.

**Dyn:** Playing the keyboard will not cause triggering. Triggering will occur when you operate the controller specified by Dynamic MIDI.

**GE Real-Time Parameters**

Here you can edit the GE realtime parameters that are selected by the KARMA module. You can also assign GE realtime parameters to the KARMA sliders and KARMA switches so that you can use them to control the phrase or pattern in realtime while you perform.

*Note:* If you use the Auto RTC Setup function of “Load GE Options,” the standard KARMA sliders and KARMA switches assignments for the RTC Model of that GE will automatically be made when you select a GE. (See “Selecting a GE” on page 172)

**1. Access the Prog P7-2: KARMA2- GE RTP page.**

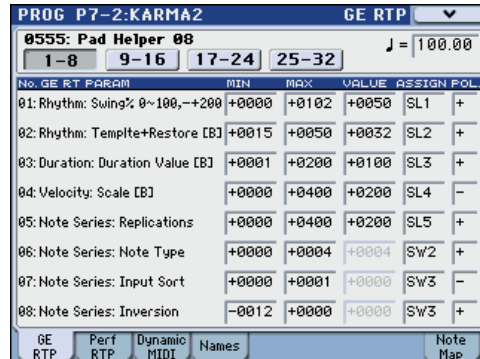

Use “GE RTC Select” to switch the set of GE realtime parameters you want to see.



These buttons display GE realtime parameters 1-8, 9-16, 17-24, or 25-32.

The number and type of GE realtime parameters you can edit here will differ depending on the selected GE. (There will be a maximum of 32.) In each GE, the parameters most useful for controlling the phrase or pattern are provided as presets.

*Note: RTC Model:* Every GE contains an internal setting that indicates its RTC Model. Based on the type or purpose of the GE, the RTC Model provides a certain degree of standardization to the over 200 internal parameters of the GE. By default, GEs that have the same RTC Model will be preset with the same GE realtime parameters.

**2. Use “VALUE,” “MIN,” and “MAX” to specify the value, minimum value, and maximum value of each GE realtime parameter.**

When you select a GE, the default parameter values that are preset for that GE will be assigned.

The values you assign here are controlled as follows by the KARMA CONTROLS you specify in the “ASSIGN” field.

SL 1-8	000-064-127 =MIN-VALUE-MAX
SLs1 1-8	000-063 = MIN, 064-127 = MAX
SW 1-8	Off = MIN, On = MAX
Dyna 1-8	Depending on Dynamic MIDI setting

**3. Use “ASSIGN” to assign each GE realtime parameter to the desired controller.**

**4. Use “POL. (POLARITY)” to specify the polarity of control.**

+: Control the parameter as shown in the table above.

-: The relationship of MIN and MAX will be inverted. For example as you move a slider from 000 to 127, the value will be controlled from the MAX value to the MIN value.



## Perf RTP (Perf Real-Time Parameters)

Here's how KARMA parameters such as KARMA key zone and KARMA module parameters (i.e., KARMA parameters other than GE realtime parameters) can be assigned to controllers.

If you've assigned these parameters to KARMA CONTROLS, you'll be able to control them in realtime while you perform (see "Control Surface sliders, & switches" on page 42, and "7-2-2b: Perf RTP 1-2, 3-4, 5-6, 7-8 (Perf Real-Time Parameters)" on page 91 of the Parameter Guide).

### 1. Access the Prog P7-2: KARMA2- Perf RTP page.

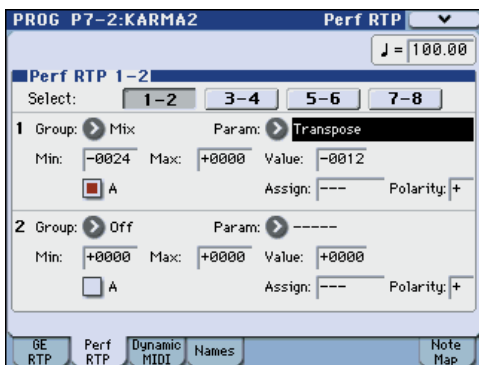

Use "Perf RTP Select" to switch the performance realtime parameter display.



As an example, let's use a KARMA slider to control the KARMA module parameter **Transpose**.

### 2. Use "Group" and "Parameter" to select the parameter you want to control.

For this example, set **Group**: Mix, and **Param** (Parameter): Transpose. Turn **A** on (checked) so that the slider will control KARMA module A.

### 3. Specify the range and value that you want to control.

The setting of the parameter will be assigned by default (-12 in this example), as described under "7-1-7a: Module Parameter-Control" on page 84 of the Parameter Guide.

For this example, set **Min**, **Max**, and **Value** to -24, +0, and -12 respectively.

### 4. Use Assign to assign the desired controller.

For this example, we'll assign SL (Slider 1).

### 5. Use Polarity to specify the polarity of control.

For this example, specify "+".

When you set CONTROL ASSIGN to KARMA and operate slider 1, the Transpose setting will change in semitone steps over a range of -24 to +0, with -12 as the center value.

*Note:* If you set **Param** (Parameter): to Transpose Octave, the change will occur in steps of one octave over a range of -24 to +0, with -12 as the center value.

If you select Transpose Octave/5th, the change will occur in alternating steps of an octave or a fifth, over a range of -24 to +0 with -12 as the center value. For example if this parameter is at the Min setting and a C3 note is sounding, moving slider 1 from 000 toward 127 will cause a pitch change of C3 → G3 → C4 → G4 → C5.

## Dynamic MIDI setting

Dynamic MIDI lets you use an M3 controller or a MIDI control message to control a specific parameter of the KARMA function. You can specify up to eight controllers (Source) and what they will do (Destination). For details, please see "Dynamic MIDI Sources & Destinations" on page 601 of the Parameter Guide.

### Naming the KARMA RTC sliders 1-8 and switches 1-8

#### 1. Access the Prog P7-2: KARMA2-Names page.



Here you can select names for the KARMA sliders and KARMA switches. You can save these settings independently for each program. The M3 provides suitable preset names for the KARMA sliders and KARMA switches.

*Note:*

#### Auto Assign RTC Name

An appropriate name for each KARMA sliders and KARMA switches will be determined based on the GE RTP or Perf RTP being controlled, and will be assigned automatically. (See "Auto Assign RTC Name" on page 117 of the Parameter Guide)

### Linking KARMA settings to Program changes

KARMA settings can be saved individually for each Program. Normally, when you select a new Program, its KARMA settings will be loaded as well. In some cases, however, you may wish to try out different Programs while keeping the KARMA settings the same.

The Global Basic page **Load KARMA when changing** (Global 0-1c) parameters let you select between these two behaviors. There are separate settings for Programs, Combinations, and Songs. To set this up:

#### 1. Go to the Global Basic page.

#### 2. Under "Load KARMA setting when changing", set the "Programs" check-box as desired.

Check the box to load the individual Programs' KARMA settings.

Un-check the box to keep KARMA settings the same, even when changing Programs.

For details, please see "Load KARMA when changing:" on page 357 of the Parameter Guide.



## KARMA function settings in Combination mode

In Combination mode (and Sequencer mode) you can use four KARMA modules (modules A, B, C, and D). In a combination, you can use the four KARMA modules and the sixteen timbre programs in a variety of ways; for example, separate phrases or patterns can play programs such as drums, bass, guitar, and strings. KARMA function settings for a combination are made in the various pages of Combi P7-1: KARMA1 and 7-2: KARMA2. Here we will explain the procedure for setting the major parameters, such as “Run” and “Solo” settings, the selection of a GE, and MIDI I/O settings. For other parameters, please see “Editing the parameters of each KARMA module” on page 178, and “7-1-1b: GE Setup” on page 161 of the Parameter Guide.

### Switching the KARMA function on/off

Each time you press the KARMA ON/OFF switch, the KARMA function will be turned on or off. When on, the switch LED will be lit.

The on/off status is saved when you write the combination.

When the KARMA function is off, all KARMA modules A, B, C, and D will be off. When the KARMA function is on, the KARMA modules will operate as specified by their “Run” and “Solo” settings.

### “Run” and “Solo” settings

1. Access the Combi P7-1: KARMA1- GE Setup A-D page.

*Note:* You can make these settings in the Combi P0: Play- KARMA GE page.

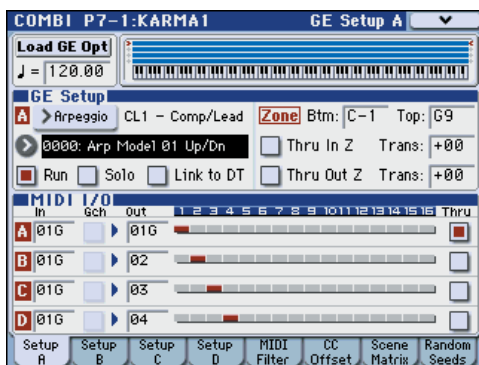

2. Use “Run” and “Solo” to select the module(s) that will operate when the KARMA function is on.

For details, please see “0-5b: GE Select” on page 125 of the Parameter Guide.

*Note:* For the preloaded combinations, when the MODULE CONTROL switch is set to MASTER, KARMA switches 1, 2, 3, and 4 will switch “Run” on/off for modules A, B, C, and D.

### Selecting a GE

Here’s how to select the GE used by each KARMA module. (See “KARMA function settings in Program mode” on page 172)

1. Access the Combi P7-1: KARMA1- GE Setup A-D page.

*Note:* You can make these settings in the Combi P0: Play- KARMA GE page.

2. Press “Load GE Opt (Load GE Options)” to access the dialog box, turn Auto RTC Setup on, and check the User RTC Model and Reset Scenes options.

“Load GE Options” specifies whether the settings of the KARMA sliders and KARMA switches will be automatically set, initialized, or maintained when you select a GE.

For this example, we’ll choose to set the slider and switch functions for KARMA modules A, B, C, and D to the standard settings for the RTC Model of the selected GE, so that you’ll be able to control the phrase or pattern immediately.

3. Use “GE Select” to select the GE used by the KARMA module.

### MIDI I/O channel settings

You can specify the MIDI input and output channels for each of the four KARMA modules used by a combination.

The MIDI input/output channel setting for each KARMA module and the MIDI channel setting for each timbre will determine the routing that specifies how the KARMA modules play the timbres. These are the most important settings when using multiple KARMA modules in a combination.

1. Access the Combi P7-1: KARMA1- GE Setup A-D page.
2. Specify the In (Input Channel) and Out (Output Channel) of each KARMA module.

**In (Input Channel):** For a combination, you will normally set this to Gch so that your keyboard playing will control the KARMA module.

**Out (Output Channel):** Set this to the MIDI channel of the timbre(s) that should be played by this KARMA module.

**Gch (Gch Also):** This option is available if Input Channel is set to other than Gch. If you select (check) this option, a module that would normally be triggered only by the Input Channel will also be triggered by the Gch. (Gch, see PG page 363)

**Thru (Timbre Thru):** If this option is on (checked), timbres differing from the global MIDI channel will sound when the KARMA function is off.

### Setting example 1:

This example shows how the “Gch (Gch Also)” option works.

1. Set MIDI Channel for the following timbres as follows.

Timbre 1: G ch  
 Timbre 2: 2 ch  
 Timbre 3: 3 ch  
 Timbre 4: 4 ch  
 Timbre 5: 5 ch

**2. Set the MIDI channels for the pads as follows.**

- Pad 1: MIDI channel = 2 ch
- Pad 2: MIDI channel = 3 ch
- Pad 3: MIDI channel = 4 ch
- Pad 4: MIDI channel = 5 ch

**3. For each KARMA module, set In (Input Channel) and Out (Output Channel) as follows.**

- KARMA module A: “Input Ch” = 2 ch, “Out Ch” = 2 ch
- KARMA module B: “Input Ch” = 3 ch, “Out Ch” = 3 ch
- KARMA module C: “Input Ch” = 4 ch, “Out Ch” = 4 ch
- KARMA module D: “Input Ch” = 5 ch, “Out Ch” = 5 ch

**4. Turn the KARMA function off.**

When you play the keyboard, timbre 1 will sound.  
When you press pads 1–4, timbres 2–5 will sound.

**5. Turn the KARMA function on.**

When you play the keyboard, timbre 1 will sound.  
When you press pads 1–4, KARMA modules A–D will each trigger a different GE which will play phrases or patterns on timbres 2–5.

**6. For KARMA module A, turn “Gch (Gch Also)” on (checked).**

**7. Turn off the KARMA function.**

When you play the keyboard, timbre 1 will sound.  
When you press pads 1–4, timbres 2–5 will sound.

**8. Turn on the KARMA function.**

When you play the keyboard, timbre 1 will sound. KARMA module A for which you turned “Gch (Gch Also)” on (checked) will trigger its GE and play a phrase or pattern on timbre 2.

When you press pads 1–4, KARMA modules A–D will trigger their respective GEs and play phrases or patterns on timbres 2–5.

**Setting example 2:**

This example shows how the “Thru (Timbre Thru)” option works.

Select a piano program for timbre 1, a bass program for timbre 2, and a drum program for timbre 3.

We’ll play timbre 1 manually from the keyboard. KARMA module A will be used to play a bass phrase on timbre 2, and KARMA module B to play a drum phrase on KARMA module B. (Make sure that the global MIDI channel is 01.)

**1. Set the MIDI Channel (see page 73) for timbres 1, 2, and 3.**

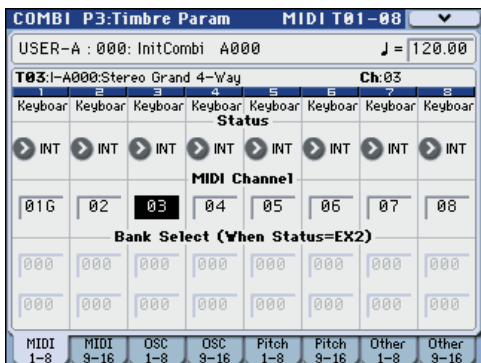

For this example, set timbre 1 to 01, timbre 2 to 02, and timbre 3 to 03. Since each timbre is set to a separate channel, the KARMA module set to the corresponding channel will play only that timbre.

**2. Set the In (Input Channel) and Out (Output Channel) of each KARMA module as follows.**

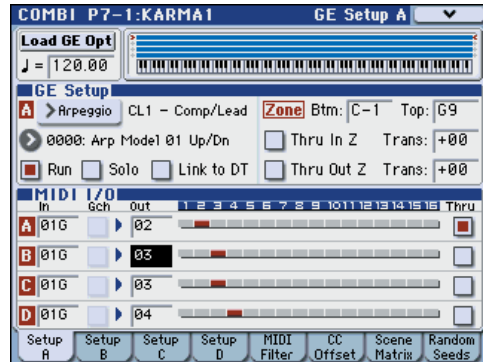

KARMA module A: “Input Ch” = G ch, “Out Ch” = 02  
KARMA module B: “Input Ch” = G ch, “Out Ch” = 03

The timbres played by the KARMA modules are shown in red, as specified by the timbre’s MIDI channel setting and the KARMA module’s Out Channel setting.



**3. For KARMA modules A and B, turn “Run” on (checked), and set “GE Select” to GE. (See “Run” and “Solo” settings on page 176.)**

KARMA module A: select a bass phrase as the GE  
KARMA module B: select a drum phrase as the GE

When the KARMA function is on, your playing on the keyboard will sound a piano on timbre 1, and will simultaneously be sent to KARMA modules A and B.

The bass phrase generated by module A is sent on MIDI channel 02 to play timbre 2.

The drum phrase generated by module B is sent on MIDI channel 03 to play timbre 3.

**4. Use “Thru (Timbre Thru)” to specify what will sound when the KARMA function is off.**

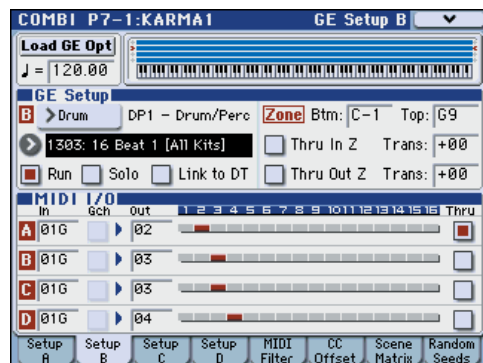

When the KARMA function is off, playing the keyboard will normally sound only the timbres that match the global MIDI channel (Ch 01).

In this example, this will be the piano sound produced by timbre 1 (Ch 01).

If “Thru (Timbre Thru)” is on (checked), you’ll be able to play timbres that differ from the global channel when the KARMA function is off.

For KARMA module A, turn “Thru (Timbre Thru)” on (checked). When the KARMA function is off, playing the keyboard will sound the piano of timbre 1 (Ch 01) as well as the bass of timbre 2 (Ch 02).

### Editing the parameters of each KARMA module

You can specify the keyboard zone in which each KARMA module operates, make MIDI filter settings, and edit KARMA module parameters. Just as for a program, these parameters can be specified independently for each KARMA module.

### GE Real-Time Parameters

Here’s how to edit the parameters of the GE selected for each KARMA module.

1. Access the Combi P7-3: KARMA3- GE RTP M-A page.

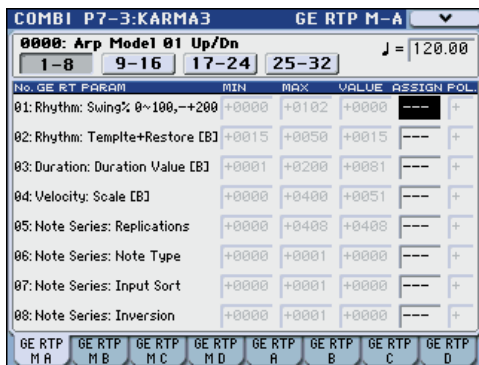

2. Set “MIN,” “MAX,” “VALUE,” “ASSIGN,” and “POL. (POLARITY).”

In the Master tabs, specifying “ASSIGN” lets you edit the “MIN,” “MAX,” “VALUE,” and “POL. (POLARITY)” settings.

3. Use the Combi P7-3: KARMA3- GE RTP M-B, C, and D pages to set the remaining Master B, C, and D.

These settings are valid when “Module Control” is set to Master.

Master lets you control any parameters of modules A, B, C, or D. You can also use a single controller to simultaneously control multiple parameters in different modules; for example, you might use Slider 1 to control the “Rhythm: Swing%” parameter of modules A, B, C, and D.

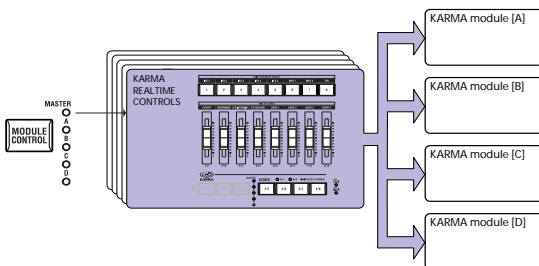

4. Press the GE RTP A tab to select Module A.
5. Set “MIN,” “MAX,” “VALUE,” “ASSIGN,” and “POL. (POLARITY).”

6. Make settings in the same way for Module B, C, and D.

The “ASSIGN” settings for module A, B, C, and D are used when MODULE CONTROL is set to A, B, C, or D respectively.

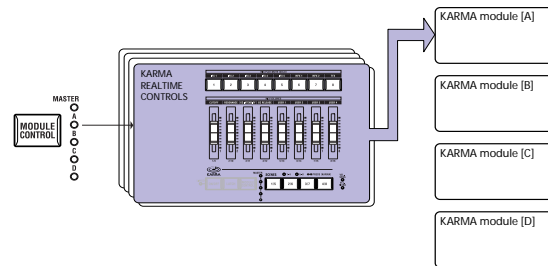

- With the appropriate “ASSIGN” settings, a GE realtime parameter of (for example) module A can be controlled independently by Master and Module A. For example you can make settings so that the Swing parameter of a drum GE on module A is controlled in MASTER by slider 1 over a range of 0–50%, and in MODULE A by slider 1 over a range of 50–100%.

Master: 0–50%  
Module A: 50–100%

In this case, if you switch MODULE CONTROL between MASTER and A while using slider 1 to control the parameter, the parameter will operate in its last-controlled state. If you set Swing to 0% in MASTER, and then switch to module A, Swing will remain at 0% as long as you don’t move slider 1. However Swing will change once you move slider 1 to control the parameter in the range of 50–100%.

1. Set MODULE CONTROL to MASTER, and set slider 1 to the minimum position. → “Swing” operates at 0%.
2. Change MODULE CONTROL to A. → “Swing” operates at 0%.
3. Move slider 1 to the maximum position. → “Swing” operates at 100%.

The internal settings are automatically controlled so that the phrase being generated does not change abruptly. In the above example when you use MASTER to set “Swing” to 0% and then switch to module A, the displayed indication is 50–100% but the parameter is actually operating at a value of 0%. In this way, you need to be aware that the displayed indication may not match the actual result.

## Perf RTP (Perf Real-Time Parameters)

In the same way as for a program, KARMA function parameters other than GE realtime parameters (e.g., KARMA module parameters) can also be assigned to controllers.

These settings are valid when MODULE CONTROL is set to MASTER.

### 1. Access the Combi P7-4: KARMA4- Perf RTP page.

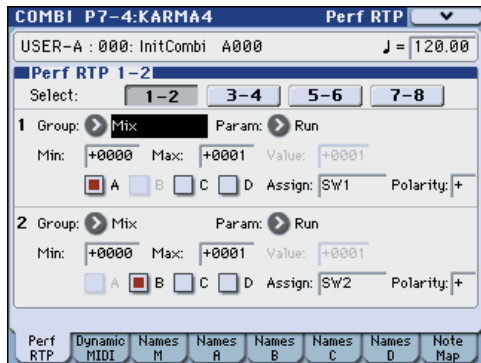

In the same way as for a program, set **Group**, **Parameter**, **Min**, **Max**, **Value**, **Assign**, and **Polarity**. In a combination, you can use the four KARMA modules A, B, C, and D.

Turn on (check) the A, B, C, and/or D boxes to select the module(s) you want to control.

In the above example, KARMA switches 1, 2, 3, and 4 are controlling the Run/Mute setting of modules A, B, C, and D respectively.

## Dynamic MIDI settings

You can make these settings in the same way as for a program. For details, please see “Dynamic MIDI Sources & Destinations” on page 601 of the Parameter Guide.

### Naming the KARMA sliders 1-8 and KARMA switches 1-8 for MASTER and module A-D

In the same way as for a program, you can select names for the KARMA sliders and KARMA switches. These settings are saved as part of the combination.

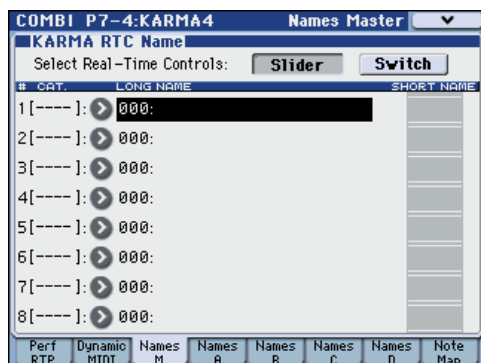

In a combination, the area in square brackets [ ] automatically shows a portion of the category name of the program selected for each timbre controlled by the KARMA sliders and KARMA switches. This lets you know the timbre whose phrase is being controlled by each KARMA slider and KARMA switches.

If more than one timbre is being controlled, the area in square brackets will indicate “MULTI.”

Auto Assign RTC Name (See “Auto Assign RTC Name” on page 117 of the Parameter Guide)

## Specifying the random seeds

For each GE realtime parameter group, you can specify whether the random seed (used to generate random values) will be shared between the four KARMA modules.

### 1. Access the Combi P7-1: KARMA1- Random Seeds page.

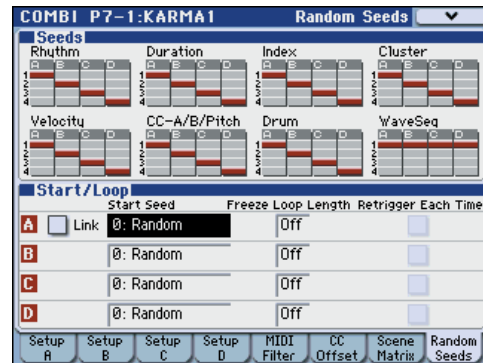

Normally, you will set the four modules to use separate random seeds as shown above; **A: 1**, **B: 2**, **C: 3**, and **D: 4**. If you have selected the same GE for two or more KARMA modules and want them to play in unison using the identical random values, you must select the same random seed for each of these modules. For details, please see “7-1-8: Random Seeds” on page 167 of the Parameter Guide.

## Linking KARMA settings to Combination changes

KARMA settings can be saved individually for each Combination. Normally, when you select a new Combination, its KARMA settings will be loaded as well. In some cases, however, you may wish to try out different Combinations while keeping the KARMA settings the same.

The Global Basic page **Load KARMA when changing** parameters let you select between these two behaviors. There are separate settings for Programs, Combinations, and Songs. To set this up:

1. Go to the Global Basic page.
2. Under “Load KARMA setting when changing”, set the “Combinations” check-box as desired.

Check the box to load the individual Combinations’ KARMA settings.

Un-check the box to keep KARMA settings the same, even when changing Combinations.

For details, please see “Load KARMA when changing:” on page 357 of the Parameter Guide.



## KARMA function settings in Sequencer mode

In Sequencer mode you can use four KARMA modules (modules A, B, C, and D). As in a combination, you can use the KARMA modules to generate independent phrases or patterns that play (for example) drum, bass, guitar, and strings programs, or you can combine the four KARMA modules and the sixteen track programs in a wide variety of ways.

The structure of the KARMA-related parameters is the same as in Combination mode. (See “KARMA function settings in Combination mode” on page 176)

In Sequencer mode, you can use the KARMA function while realtime-recording song tracks or patterns.

The note-on/off data and MIDI control data generated by a KARMA module can be recorded as events in a track or pattern. At this time, you can use the KARMA sliders and KARMA switches to control the phrase in realtime while you record it.

You can also copy the settings from a combination, and use multi-track recording to realtime-record your keyboard performance.

 Data from the internal sequencer is not input to the KARMA module, and therefore you cannot use note data from the internal sequencer to trigger a KARMA module so that it generates phrases etc.

Here we'll explain how to use the Auto Song Setup function to get started with realtime recording. We will also describe the procedure for realtime recording (single-track recording) using the KARMA function, and for realtime recording (multi-track recording) by copying the settings from a combination.

### Auto Song Setup

The Auto Song Setup function automatically copies the settings of a program or combination into a song, and then puts the M3 in record-ready mode. You can then begin recording immediately just by pressing the SEQUENCER START/STOP switch. This lets you seamlessly move from playing a program or combination into producing a song, so that phrases or ideas for a song that occur to you while using the KARMA function can be immediately turned into a song.

**Procedure (using the example of Combination mode)**

1. Enter Combination mode.
2. In the Combi P0: Play page, select a combination and edit the KARMA RTC parameters etc. as desired.

*Note:* If you want to keep the edited state of your combination, execute “Update Combination” or “Write Combination.”

3. Hold down the ENTER switch and press the REC/WRITE switch.

The “Setup to Record” dialog box will appear.

4. To execute the Auto Song Setup function, press the OK button. If you decide to cancel, press the Cancel button.

You will automatically move to Sequencer mode, and the settings of the combination will be copied to a song.

The copy-destination song will be the first unused song.

### Content copied from a combination

The same content will be copied as when you execute the **Copy From Combi** menu command with **IFXs**, **MFXs**, and **TFX** checked, and **Multi REC Standby** checked. For details, please see “Copy From Combi (Copy from Combination)” on page 273 of the Parameter Guide.

### Content that is copied from a program

The copied content is the same as when you execute with the following settings in the menu command **Copy From Program** dialog box (see PG page 273).

Check “IFXs,” “MFXs,” and “TFX,” and specify “To:” as Track 01.

Check “KARMA,” and specify “To:” as KARMA Module A.

Check “with Drum Track,” and specify “To:” as Drum Track Track 10.

5. The M3 will automatically enter record-ready mode, and the metronome will begin sounding according to the Metronome setting (Seq P0-1: Play/REC-Preference, Metronome Setup).
6. Press the SEQUENCER START/STOP switch to begin realtime recording. When you've finished recording, press the START/STOP switch once again. (See “Recording MIDI in real-time” on page 85)

### Realtime recording using the KARMA function (single-track recording)

In the following example, we'll use the KARMA function to record a drum pattern on track 1.

1. Select the desired drum program for track 1 as described in the procedure for realtime-recording a track and for preparing to record (see page 85).

Also make any other necessary settings for recording, such as setting **Track Select** to T01.





**2. Access the Seq P7-1: KARMA1- GE Setup A page.**

Make MIDI I/O settings for the KARMA modules so that KARMA module A will play track 1 (See “KARMA function settings in Combination mode” on page 176).

For KARMA module A, set the **In (Input Channel)** and **Out (Output Channel)** to 01 and 01 respectively. Setting them to Tch and Tch will have the same result. For details, please see “7-1-1c: MIDI I/O” on page 244 of the Parameter Guide.



As specified by the MIDI track’s MIDI Channel setting and the KARMA module’s Out Channel setting, the MIDI track played by the KARMA module is displayed in red.

**3. Select a GE for KARMA module A, and set its parameters.**

You are free to select a GE and make settings as desired, but in this example we’ll use the **Copy KARMA Module** menu command to copy all of the program’s KARMA function settings. This is an easy way to set up and record the phrase or pattern that the program’s KARMA function is generating.

**1. Use the menu button located in the top left of the display to open the menu, and choose Copy KARMA Module.**

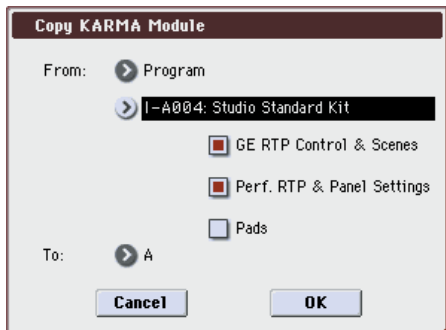

Specify the copy-source program. Turn on (check) **GE RTP Control & Scenes** and **Perf. RTP & Panel Settings**. Press OK to execute the copy.

The settings of the KARMA sliders, KARMA switches, and scenes will be copied to Module Control A.

**2. Press the KARMA ON/OFF switch to turn on the KARMA function.**

When you play the keyboard, the KARMA function will generate a drum pattern just as it did for the program.

**3. Use the SEQUENCER REC/WRITE switch and the START/STOP switch to realtime-record on track 1. (See “Recording MIDI in real-time” on page 85)**

You can operate the KARMA sliders/switches and the SCENE switches while recording, and the changes in the pattern or sound that occur will be recorded just as they occur.

The song tempo and the KARMA function tempo cannot be set independently.

**4. If you want the KARMA module to be in synchronization with the sequencer during recording, check the Quantize Trigger option.**

Access the Seq P7-2: KARMA2- Trigger A page.

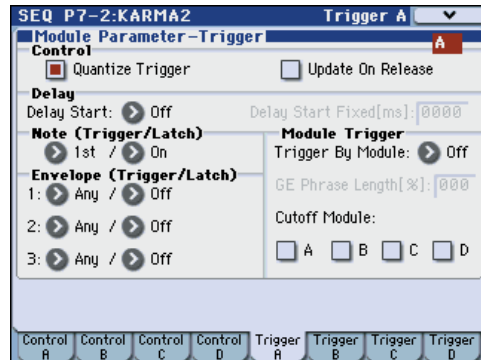

The trigger timing will be synchronized to sixteenth-note intervals of the sequencer beat. (See “Synchronizing the KARMA function” on page 182)

**5. You can synchronize the KARMA module to the start timing of the sequencer.**

- While KARMA is running, press the START/STOP switch; the KARMA function will synchronize to the synthesizer timing.
- If you again press the START/STOP switch, the sequencer and the KARMA function will both stop. If you want to stop only the KARMA function, press the (KARMA) ON/OFF switch to turn it off.
- If you want the KARMA function to start at the moment recording begins, press the (KARMA) ON/OFF switch to turn it on, and then play the keyboard during the pre-count before recording. The KARMA module will not be triggered immediately, but will be triggered in synchronization with the sequencer when recording begins. (See “Synchronizing the KARMA function” on page 182)

**Realtime multi-track recording using settings copied from a combination**

The pre-loaded combinations include a diverse array of combinations that take full advantage of the KARMA function. You can play these combinations to stimulate ideas for songs, and record your playing to create basic tracks. Many of these combinations consist of timbres and KARMA modules with differing MIDI channel settings.

In the example below, we’ll show how you can use multi-track recording to record a performance consisting of multiple MIDI channels.

- 1. We’ll start by copying the settings of a combination into a song. Access the Seq P0-1: Play/REC- Program T01-08 page.**
- 2. In the upper left of the display, press the menu button to open the menu, and choose Copy From Combi.**

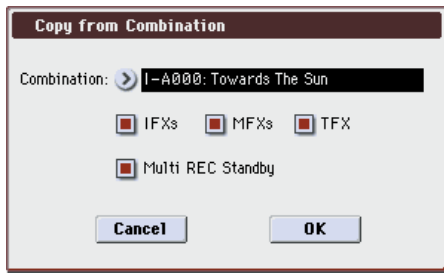

Select the copy-source combination. Turn **IFXs**, **MFXs**, **TFX**, and **Multi REC Standby** on (checked). Press OK to execute the copy.

3. **The settings of the combination's timbres 1–16 will be copied to MIDI tracks 1–16. Effect settings, KARMA settings, and all other common parameters will be copied to the tracks of the song.**
4. **Choose Track Select. Select a track whose MIDI channel matches the global MIDI channel.**

Press the KARMA ON/OFF switch to turn the KARMA function on, and play the keyboard and/or pads to make the KARMA function begin playing in the same way as it did in the copy-source combination. (Depending on the track you selected in “Track Source,” the performance may not be the same as when you were playing the combination. Be sure to select the track whose MIDI channel is the same as the global MIDI channel.)

5. **Perform multi-track recording. Make preparations for recording as described in “Multi (multitrack recording)” on page 87. Turn “Multi REC” on (checked).**



Set the tracks you're not recording to either Play or Mute. However if you're recording the performance of a combination, and none of the tracks have already been recorded, it's ok to leave all tracks set to REC.

6. **Press the REC/WRITE switch and then the START/STOP switch to begin realtime recording. (See “Recording MIDI in real-time” on page 85)**

While you record, you can operate the KARMA sliders, KARMA switches, and KARMA SCENE switches to vary the pattern or sound. The changes you create will be recorded just as you make them.

- ⚠ The song tempo and KARMA function tempo cannot be set independently.

## Synchronizing the KARMA function

### The “Quantize Trigger” parameter

The trigger timing of a KARMA module will depend on the setting of its **Quantize Trigger** parameter.

**On (checked):** The trigger timing of a KARMA module will be quantized to a sixteenth-note interval of the base tempo.

**Off (unchecked):** The KARMA module will be triggered at the timing at which you play the keyboard.

For details, please see “Quantize Trigger” on page 88 of the Parameter Guide.

*Note:* If you want a Drum Track function to synchronize to the currently-playing KARMA function, go to the Prog P1: DT/XY/Crls– DrumTrk Pattern page, Combi, Seq P1: DT/XY/Crls– Drum Track and turn **Trigger Sync** on. (See page 193)

### Synchronization between KARMA modules A, B, C, and D

In Combination and Sequencer modes, four KARMA modules can be running. Each module has a **Quantize Trigger** setting that determines how that module will synchronize with the other modules.

**Quantize Trigger Off:** The KARMA module will be triggered at the timing at which you play the keyboard. There will be no synchronization between KARMA modules; each will be triggered at their own timing.

**Quantize Trigger On:** The KARMA module will synchronize to sixteenth-note intervals of the timing the first-triggered KARMA module that is currently running.

If you want to simultaneously trigger multiple KARMA modules from the keyboard or pads, turn **Quantize Trigger** on for each of these KARMA modules.

### Synchronization with songs, patterns, and RPPR performance in Sequencer mode

If you want a KARMA module to play (or be recorded) in synchronization with the currently-playing song, pattern, or RPPR, turn **Quantize Trigger** on.

**Quantize Trig Off:** The KARMA module will be triggered at the timing at which you play the keyboard. It will not synchronize to the currently-playing song, pattern, or RPPR.

**Quantize Trig On:** The trigger timing of the KARMA module will be quantized to a sixteenth-note interval of the currently-playing song, pattern, or RPPR.

*Note:* If you want patterns played by RPPR to synchronize to the currently-operating KARMA function, set **Sync** (Seq P10: Pattern/RPPR– RPPR Setup page) to SEQ.

---

## Synchronization with Drum Track patterns, performance

If you want the KARMA module to synchronize to the currently-playing drum track pattern, turn **Quantize Trigger** on.

**Quantize Trig Off:** The KARMA module will be triggered at the timing at which you play the keyboard. It will not synchronize to the currently-playing drum track pattern.

**Quantize Trig On:** The KARMA module will be triggered in synchronization with the currently-playing drum track pattern at the nearest sixteenth-note interval.

*Note:* If you want the Drum Track pattern to synchronize with the currently-operating KARMA function, set **Sync** (Trigger, in the Drum Track page of each mode) to On.

---

## Synchronization with song start/stop

### Synchronization with a song in Sequencer mode

- While the KARMA function is running, pressing the START/STOP switch will synchronize the KARMA function with the sequencer.  
The KARMA function will be reset, and the phrases or patterns it generates will start from the beginning.
- While the sequencer is playing and the KARMA function is stopped, and you change the location by pressing the LOCATE switch etc., the KARMA function will be reset, and the phrases or patterns it generates will start from the beginning.
- If you then press the START/STOP switch, the sequencer and the KARMA function will both stop. If you want to stop only the KARMA function, press the (KARMA) ON/OFF switch.
- If you want the KARMA function to start the moment recording begins, press the (KARMA) ON/OFF switch, and then play the keyboard during the pre-count before recording. The KARMA modules will not be triggered immediately, but will be triggered in synchronization with the sequencer the moment recording starts.

---

## Slave operation

Connect the MIDI OUT of your external MIDI device to the M3's MIDI IN.

Set **MIDI Clock** (Global, see PG page 363) to External MIDI or External USB. The M3 will synchronize to MIDI realtime clock and realtime command messages it receives from the connected MIDI device.

*Note:* If the M3 is set to **MIDI Clock**= Auto, it will also synchronize to the external MIDI device in the same way if MIDI realtime clock messages are being received from the external device.

### Synchronization to MIDI clock

The KARMA function will synchronize to a tempo based on the external MIDI clock timing.

### Synchronization with MIDI realtime commands

In Sequencer mode, Song Start, Continue, and Stop messages that the M3 receives will control song playback and recording just as when you operate the front panel START/STOP switch. The KARMA function also will be controlled in the same way as when you operate the front panel START/STOP switch. (See "Synchronization with song start/stop")

When the M3 receives a Song Position Pointer message, it will change the location of the song just as when you change the song location by operating the M3, and the KARMA function will be controlled in the same way as when you change the location on the M3.

In Program and Combination modes, Song Start, Continue, and Stop messages that the M3 receives will control the KARMA function.

- While the KARMA function is running, Song Start, Continue, and Song Position Pointer messages received by the M3 will reset the KARMA function, causing the generated phrases or patterns to start from the beginning.
- If a Song Stop message is received, the KARMA function will stop.

---

## Master operation

Connect the M3's MIDI OUT to the MIDI IN of your external MIDI device.

Set **MIDI Clock** (Global 1-1a) to Internal. The connected external MIDI device will synchronize to the MIDI realtime clock and realtime commands it receives.

*Note:* The same applies if **MIDI Clock**=Auto and MIDI realtime clock messages are being transmitted. For details, please see "MIDI Clock (MIDI Clock Source)" on page 364 of the Parameter Guide.

### Synchronization via MIDI clock

The connected external MIDI device will synchronize to the MIDI clock of the M3.

## Synchronization via MIDI realtime commands

### Enable Start/Stop Out in Prog/Combi

You can set up M3 so that starting and stopping KARMA in Program and Combination modes will also control start and stop on external MIDI devices, such as sequencers and drum/groove machines (such as the KORG Electribe series).

To do so:

1. **Go to the Global MIDI page.**
  2. **Under MIDI Routing Setup, turn on “Enable Start/Stop Out in Prog/Combi.”**
- In Program and Combination modes, playing a note-on from the keyboard or pads to trigger the GE selected for a KARMA module will also cause the MIDI system realtime message “Start” to be sent at the trigger timing.
  - After the Start message has been sent, turning off KARMA ON/OFF will send the MIDI system realtime “Stop” command.

# Drum Track function

## Overview

### What is the Drum Track function?

The Drum Track function makes it easy to play the M3's high-quality drum programs using a wide variety of Drum Track patterns.

It provides a convenient way for you to hear Drum Track patterns while you try playing various phrases on a program or combination, or working out the outline of your song. Then when you've come up with some ideas, you can use the Auto Song Setup function to immediately start recording in Sequencer mode.

Regarding the Drum Track patterns, you can use preset patterns that cover a wide range of musical styles, as well as user patterns that you yourself created.

Preset	P001...P522	Preset Drum Track patterns
User	U000...U999	User Drum Track patterns

You can write your own patterns into U000–U999. User patterns you've created in Sequencer mode can be converted into user Drum Track patterns.

The Drum Track pattern will start immediately when you press the DRUM TRACK ON/OFF switch, or when you play the keyboard after pressing the ON/OFF switch. If you're starting the pattern by playing the keyboard, you have the option of starting it by using a specific range of notes or velocities.

You can also link this with the KARMA function.

The sound of the Drum Track program can be adjusted using the drum track EQ, and you can also easily change the effect routing settings.

## Performing with the Drum Track function

### Using the Drum Track function in Program mode

#### Selecting a program and turning the Drum Track function on/off

1. Press the MODE PROG switch to enter Program mode, and select the desired program. (See "Selecting Programs" on page 37)

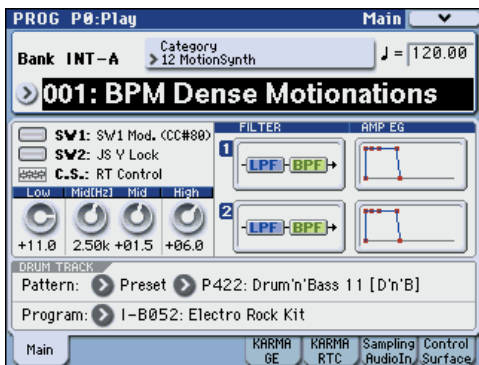

2. Press the DRUM TRACK ON/OFF switch.

The ON/OFF switch will light or blink, depending on the setting (**Trigger Mode**) of the program.

If lit: The Drum Track pattern will start according to the **Sync** setting. When you turn it off, the pattern will stop. (This will occur if **Trigger Mode** is Start Immediately.)

If blinking: The Drum Track pattern will be ready to start. It will start when you play the keyboard or when

a MIDI note-on is received. (This will occur if **Trigger Mode** is Wait KBD.) If the front panel KARMA LINKED and KARMA ON/OFF switches are lit, the KARMA performance will start/stop together with the drum track.

#### Adjusting the performance tempo

1. You can use the TEMPO knob or the TAP TEMPO switch to adjust the performance tempo.

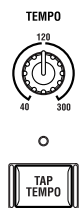

This will change the "♩=" value located in the upper right of the display. You can adjust the tempo in a range of 40.00–300.00. The LED located above the TAP TEMPO switch will blink at intervals of a quarter note (♩).

As an alternative to using the TEMPO knob or the TAP TEMPO switch, you can choose "♩=" in the display, use numeric keys 0–9 to enter the tempo, and then press the ENTER switch. You can also use the VALUE controller to set the tempo. The LED will blink at the tempo you specify.

**Note:** The setting of the TEMPO knob is also saved when you write a program.

 If the Global P1: MIDI- MIDI Basic page **MIDI Clock** parameter is set to External MIDI, External USB, or set to Auto and MIDI Clock messages are being received, the display will indicate "♩=" EXT, and the M3 will be synchronized to an external MIDI device. In this case, you won't be able to change the tempo by operating the M3.



### Selecting a Drum Track pattern and Drum Track program

1. Access the Prog P0: Play– Main page.

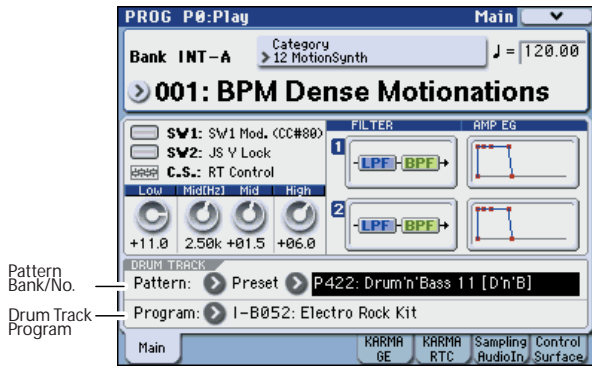

2. Select a Drum Track pattern. Use “Pattern Bank” to select the preset or the user bank, and use “Pattern No.” to select the pattern number.
3. Use “Drum Track Program” to select the program that will play the Drum Track pattern.

*Note:* You can only select programs of category number 15 (Drums). If you want to use an original program you created as the Drum Track program, save it with “Category” set to 15 (see page 50).

*Note:* If you’ve selected an empty pattern, you won’t be able to turn on the DRUM TRACK ON/OFF switch. These parameters can also be set from P1: Basic/DT/Ctrls.

### Linking with the KARMA function

You can link the KARMA function to the drum track start/stop.

1. Access the Prog P0: Play– KARMA GE page.
2. Turn “Link To Drum Trk” on (selected). The front panel KARMA LINKED LED will light.

If Link To Drum Trk is on (selected), the KARMA function will be linked with the drum track start/stop.

3. Turn the KARMA ON/OFF switch on.

Even when you play the keyboard (or receive a note-on), KARMA will not be triggered.

4. Turn the DRUM TRACK ON/OFF switch on.

If the DRUM TRACK ON/OFF switch lights, KARMA will be triggered simultaneously with the Drum Track pattern, and will begin operating (while you hold down a key, or if the KARMA LATCH switch is on).

If the switch blinks, KARMA will be triggered simultaneously with the Drum Track pattern when you play the keyboard (or receive a note-on), and will begin operating.

If you turn off the DRUM TRACK ON/OFF switch while KARMA is operating, KARMA will also stop.

For details on linking with the KARMA function, please see page 191.

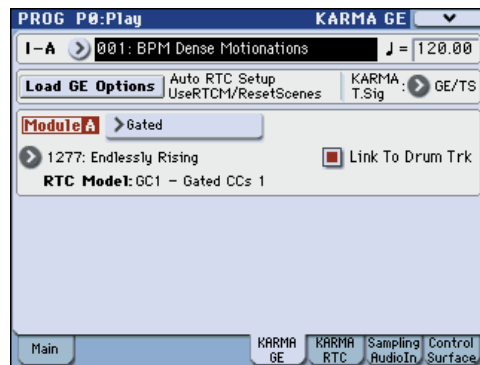

### Settings in the control surface

You can use the control surface to control the volume, play/mute, and solo on/off status of the drum track.

1. Play a Drum Track pattern. (See “Selecting a program and turning the Drum Track function on/off” on page 185)
2. Press the CONTROL ASSIGN MIXER switch to make the “T1–8” LED light.
3. Press the Control Surface tab to access the Prog P0: Play– Control Surface page.

This page displays and reflects the control surface settings. It’s convenient to watch this page while using the control surface, since you’ll be able to view the parameter assignments and the precise values.

*Note:* You can use the control surface for control regardless of the page that’s currently shown in the display.

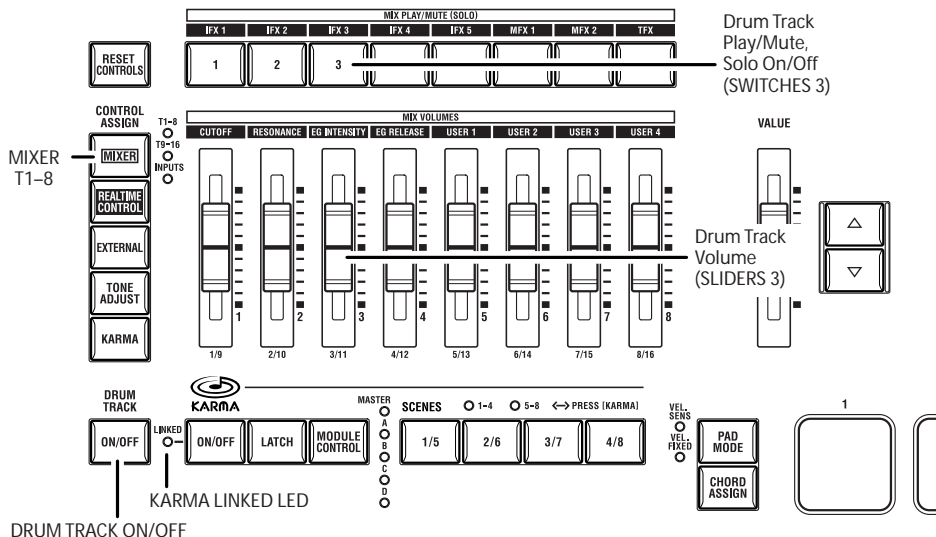

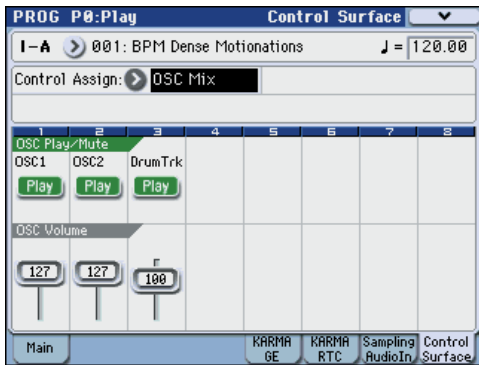

4. Operate slider 3 to adjust the volume of the drum track.
5. If the display indicates OSC Play/Mute, pressing switch 3 will change the Play/Mute status of the drum track.
6. Press the menu command button in the upper right of the display and choose “Panel-SW Solo Mode.”

The menu will close, and the OSC Play/Mute indication in the display will change to OSC Solo.

Alternatively, you can switch between OSC Play/Mute and OSC Solo by holding down the ENTER switch and pressing numeric key 1.

7. If the display indicates OSC Solo, pressing switch 3 will change the Solo On/off setting of the drum track.

## Using the Drum Track function in Combination mode

### Selecting a combination and turning the Drum Track function on/off

1. Press the MODE COMBI switch to enter Combination mode, and select the desired combination. (See “Selecting Combinations” on page 65)



2. Press the DRUM TRACK ON/OFF switch.

The ON/OFF switch will light or blink, depending on the setting (**Trigger Mode**) of the combination.

If lit: The Drum Track pattern will start according to the **Sync** setting. When you turn it off, the pattern will stop. (This will occur if **Trigger Mode** is Start Immediately.)

If blinking: The Drum Track pattern will be ready to start. It will start when you play the keyboard or when a MIDI note-on is received. (This will occur if **Trigger Mode** is Wait KBD.) If the front panel KARMA LINKED and KARMA ON/OFF switches are lit, the KARMA performance will start/stop together with the drum track.

### Adjusting the performance tempo

You can use the TEMPO knob or the TAP TEMPO switch to adjust the performance tempo.

### Selecting a Drum Track pattern and Drum Track program

Unlike its operation in Program mode, the Drum Track function in Combination mode does not have its own dedicated track (timbre). The program that plays the Drum Track pattern will use the timbre you specify.

1. In the Combi P0: Play– Program T01–08 page or T09–16 page, select the timbre that you want to use for the drum track, and then select the Drum Track program.

In the following illustration, we’ve selected timbre 10 for use by the drum track.

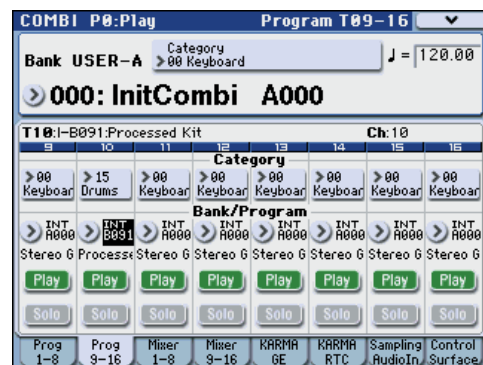

2. Specify the MIDI channel of the drum track timbre.

Be aware that if another timbre uses the same MIDI channel, that timbre will also be sounded.

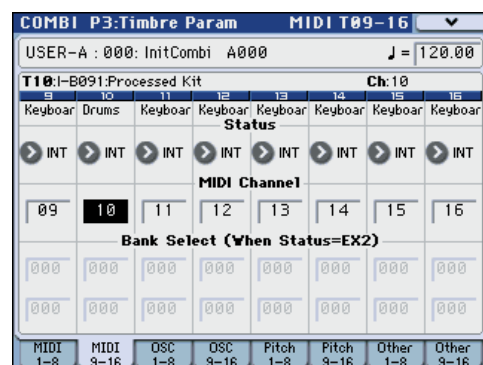

3. Access the Combi P1: DT/XY/Ctrls– Drum Track page.

Specify the drum track’s output MIDI channel **Output**. Set this to match the **MIDI Channel** of the timbre you specified in step 2.

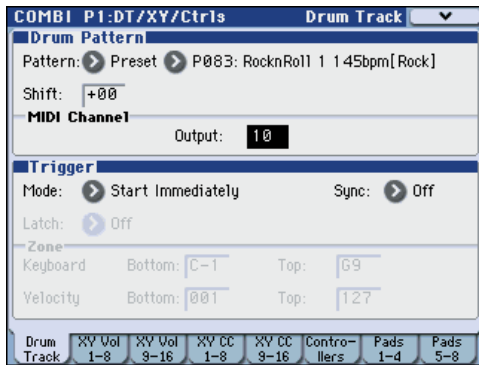

4. Select a Drum Track pattern. Use “Pattern Bank” to select the preset or user bank, and use “Pattern No.” to select the pattern number.

*Note:* If you select an empty pattern, you won’t be able to turn the DRUM TRACK ON/OFF switch on.

5. Press the DRUM TRACK ON/OFF switch to verify that the pattern sounds correctly.

The method of triggering will depend on the Trigger settings. If **Trigger Mode** is Start Immediately, the Drum Track pattern will start when you press the ON/OFF switch. For details on the Trigger settings, please see “Trigger settings for the Drum Track pattern” on page 189).

# Drum Track function settings

## Drum Track function settings in Program mode

In Program mode, the drum track has its own dedicated track. Drum Track function settings in Program mode are made in the Prog P1: Basic/DT/Ctrl- DrumTrk Pattern page and the DrumTrk Program page. Here we will explain how to make the most important parameter settings. For details on the parameters, please see “1-4: DrumTrk Program (DrumTrack Program)” on page 29 of the Parameter Guide and following.

### Switching the Drum Track function on/off

Each time you press the DRUM TRACK ON/OFF switch, the Drum Track function will be turned on or off. When on, the switch LED will be lit or blinking.

The lit or blinking state will depend on the **Trigger Mode** setting.

If the switch LED is blinking, **Trigger Mode** is set to Wait KBD Trig. With the Wait KBD Trig setting, the on/off status of the DRUM TRACK ON/OFF switch is also saved when you save the program.

If the switch LED is lit, **Trigger Mode** is set to Start Immediately. With the Start Immediately setting, the switch status is always saved as Off regardless of the on/off status of the DRUM TRACK ON/OFF switch.

### Selecting a Drum Track pattern

Here’s how to select the Drum Track pattern. As explained earlier, you can also select this in the Prog P0: Play- Main page (see page 186).

1. Access the Prog P1: Basic/DT/Ctrl- DrumTrk Pattern page.

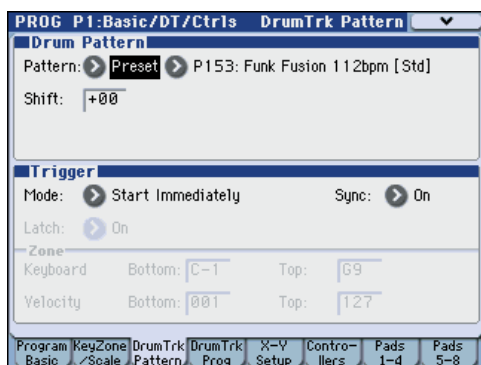

2. Use “Pattern Bank” to select the preset or user bank, and use “Pattern No.” to select the pattern number.

If you change the **Shift** value, the Drum Track pattern will be shifted in semitone steps, causing different instruments of the drum kit to play.

### Trigger settings for the Drum Track pattern

Here’s how to specify how the Drum Track pattern will be triggered.

1. Access the Prog P1: Basic/DT/Ctrl- DrumTrk Pattern page.
2. “Trigger Mode” specifies how the Drum Track pattern will be triggered.

**Start Immediately:** When you press the DRUM TRACK ON/OFF switch to turn it on, the LED will light and the Drum Track pattern will start according to the **Sync** setting. It will stop when you turn off the switch.

**Wait KBD Trig:** When you press the DRUM TRACK ON/OFF switch to turn it on, the LED will blink and the Drum Track pattern will wait to start. When you play the keyboard or receive a MIDI note-on, the Drum Track pattern will start according to the **Sync** setting.

3. Specify the **Sync** setting.

**Off:** The Drum Track pattern will not synchronize to the currently-running KARMA, but will start immediately.

**On:** The Drum Track pattern will synchronize to the currently-running KARMA.

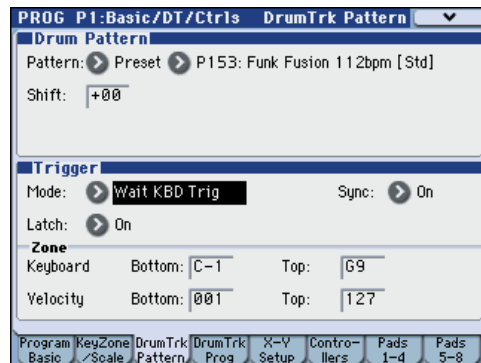

4. If “Trigger Mode” is set to Wait KBD Trig, specify the “Latch” setting. “Latch” specifies whether the Drum Track pattern will continue playing even after you take your hand off the keyboard.

**Off:** If the DRUM TRACK ON/OFF switch is on (the LED will blink), the pattern will start when you play the keyboard (note-on). The pattern will stop when you release the keyboard (note-off).

**On:** If the DRUM TRACK ON/OFF switch is on (the LED will blink), the pattern will start when you play the keyboard (note-on). The pattern will continue when you release the keyboard (note-off). The pattern will stop when you turn the DRUM TRACK ON/OFF switch off (the LED will go dark).

**Use KARMA Latch Switch:** The on/off status of the KARMA LATCH switch will correspond to the above Off and On modes of operation. You will probably want to use this in conjunction with KARMA’s Latch operation.

5. If “Trigger Mode” is set to Wait KBD Trig, specify the **Keyboard Zone** and **Velocity Zone**.

These settings specify the range of keys and velocities that will trigger the Drum Track pattern when you play the keyboard (or receive a note-on).

### Selecting a Drum Track program

Here's how to select the Drum Track program. You can also make this selection in the Prog P0: Play- Main page (see page 186), but the DrumTrk Program page also allows you to specify the EQ, detuning, and bus in addition to selecting the program.

1. Access the Prog P1: Basic/DT/Ctrl- DrumTrk Program page.

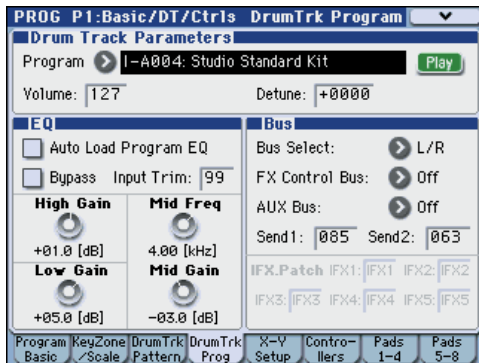

2. Use “Program (Select)” to select a drum program.  
*Note:* You can only select programs of category number 15 (Drums).
3. Use “Volume” to specify the volume of the Drum Track program.
4. Use “Detune” to adjust the pitch in units of one cent. One cent is 1/100th of a semitone. This adjusts the overall pitch of the Drum Track program.

*Note:* You can adjust the pitch of each drum kit in Global P5: Drum Kit.

### EQ adjustments for the Drum Track program

You can adjust a three-band EQ for the Drum Track program. If you turn “Auto Load Program EQ” on (selected), the three-band EQ settings specified for the program will be automatically loaded when you switch Drum Track programs. Normally you will leave this selected. You are free to adjust the three-band EQ settings that are loaded automatically. These adjustments are applied relative to the original settings of the program.

### MIDI transmission and reception for the drum track

In Program mode, the Drum Track function transmits and receives on the following MIDI channels.  
**Receive:** If you're controlling the triggering by playing the keyboard, the drum track will receive on the global MIDI channel.  
**Transmit:** The drum track will transmit on the MIDI channel specified by Drum Track **Prog MIDI Ch** (default: channel 10). (Note data etc. of the Drum Track program will be transmitted.)

*Note:* MIDI transmission of the pattern data is enabled if Drum Track **Prog MIDI Out** (Global 1-1a) is selected. The default setting is off (unselected).

The Drum Track program does not transmit or receive program changes.

## Drum Track function settings in Combination mode

Unlike Program mode, Combination mode does not have a dedicated track for the Drum Track function. You'll need to specify a timbre 1-16 as the one for use by the Drum Track program.

Then set the drum track's output MIDI channel **Output** to match the timbre's MIDI channel **MIDI Channel** so that the Drum Track program can be played.

For details, please see “Selecting a Drum Track pattern and Drum Track program” on page 186.

### MIDI transmission and reception for the drum track

In Combination mode, the Drum Track function transmits and receives on the following MIDI channels.

**Receive:** If you're controlling the triggering by playing the keyboard, the drum track will receive on the global MIDI channel.

**Transmit:** The drum track will transmit on the MIDI channel specified by the Drum Pattern **Output** setting of each combination.

Set this to match the MIDI channel of the timbre you've specified for the drum program.

If the timbre's **Status** is EXT or EX2, the note data etc. of the Drum Track pattern will be transmitted.



## Drum Track function settings in Sequencer mode

The parameters for the Drum Track function are structured in the same way as in Combination mode. Assign the Drum Track program to the desired track 1-16.

However, while a combination triggers the Drum Track pattern on the global MIDI channel, a song triggers the Drum Track pattern on the MIDI channel specified by Drum Pattern **Input**. Normally you'll set this to Tch. With the Tch setting, the MIDI channel of the track selected by **Track Select** will automatically be used as the trigger channel.

For details, please see "Selecting a Drum Track pattern and Drum Track program" on page 186.



In Sequencer mode you can use the Drum Track function while realtime-recording a song track or pattern.

The note-on/off data transmitted by the Drum Track pattern can be recorded as events in a track or pattern.

 You can't use note data from the internal sequencer as a trigger to start patterns for the Drum Track function.

When you've used the Drum Track function with a program or combination to come up with an idea for a song, you can then use the Auto Song Setup function to immediately start realtime-recording (see page 180).

### MIDI transmission and reception for the drum track

In Sequencer mode, the Drum Track function transmits and receives on the following MIDI channels.

**Receive:** The drum track will receive on the MIDI channel specified by the Drum Pattern **Input** setting of each song. Normally you'll set this to Tch and use the M3's keyboard to control the triggering.

**Transmit:** The drum track will transmit on the MIDI channel specified by the Drum Pattern **Output** setting of each song. Set this to match the MIDI channel of the MIDI track for which you've assigned the drum program.

If the track's **Status** is BTH, EXT, or EX2, note data etc. of the Drum Track pattern will be transmitted.

## Using the KARMA and Drum Track functions together

If you're using the Drum Track function and KARMA function together, you can link the start/stop operation of both, and specify whether the Drum Track pattern will operate for each KARMA scene.

### Settings in Program mode

#### Linking the KARMA performance with the Drum Track pattern start/stop

Here's how to start/stop the KARMA performance along with the Drum Track pattern.

1. Access the Prog P0: Play- KARMA GE page.

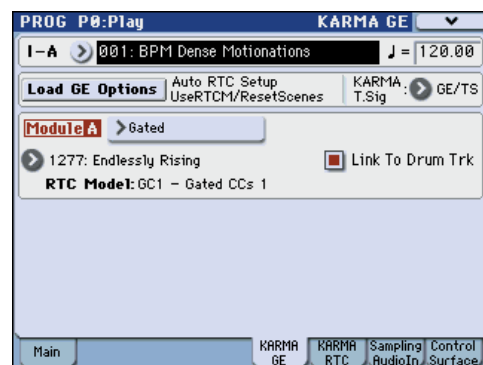

2. Turn "Link To Drum Trk" on (selected). The front panel KARMA LINKED LED will light.

If **Link To Drum Trk** is on (selected), the KARMA function will be linked with the drum track start/stop.

*Note:* You can also make this setting by using the Prog P7-1: KARMA1- GE Setup page **Link to DT** (Link To Drum Trk) parameter.

3. Turn the KARMA ON/OFF switch on.

Even when you play the keyboard (or receive a note-on), KARMA will not be triggered.

4. When you turn the DRUM TRACK ON/OFF switch on, the drum track will start at the specified timing.

If **Trigger Mode** is set to Start Immediately, KARMA will be triggered and begin operating when you turn the DRUM TRACK ON/OFF switch on (if you're playing the keyboard, or if the KARMA LATCH switch is on).

If **Trigger Mode** is set to Wait KBD Trig, operation will begin when you play the keyboard (or when a note-on is received).

If you turn the DRUM TRACK ON/OFF switch off while KARMA is operating, KARMA will also stop.

## Specifying whether the drum track will operate for each KARMA scene

Here's how to specify whether the drum track will operate for each KARMA scene.

1. Access the Prog P7: KARMA1- Drum Track Control page.

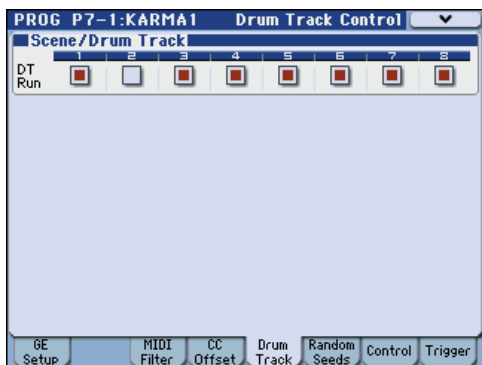

2. In "DT Run" (Drum Track Run), clear the check box of each scene for which you don't want the drum track to operate.

For example, you might turn this on (selected) for scene 1 and off (cleared) for scene 2.

3. Press the KARMA ON/OFF switch to turn it on.

Verify that the SCENES 1-4 LED is lit, and then press the SCENES 1/5 switch to select scene 1 (see page 168).

4. Press the DRUM TRACK ON/OFF switch.

If **Trigger Mode** is set to Wait KBD Trig, play the keyboard (or transmit a note-on).

Verify that KARMA and the Drum Track pattern are playing.

5. Press the SCENES 2/6 switch to select scene 2.

You'll stop hearing the Drum Track pattern. If you press the SCENES 1/5 switch, you'll hear the Drum Track pattern again.

6. Press the SCENES 2/6 switch once again to select scene 2.

If you now press the KARMA ON/OFF switch to turn it off, you will no longer hear the drum track.

To retrigger the drum track, turn the DRUM TRACK ON/OFF switch off, and then on again, and then play the keyboard.

## Settings in Combination and Sequencer modes

### Linking the KARMA performance with the Drum Track pattern start/stop

In Combination mode and Sequencer mode, the KARMA function can operate up to four KARMA modules simultaneously. Start/stop for each KARMA module can be synchronized with the Drum Track pattern start/stop.

Here we'll explain how to make settings in Combination mode. Settings for Sequencer mode are the same as in Combination mode.

1. Access the Combi P0: Play- KARMA GE page.

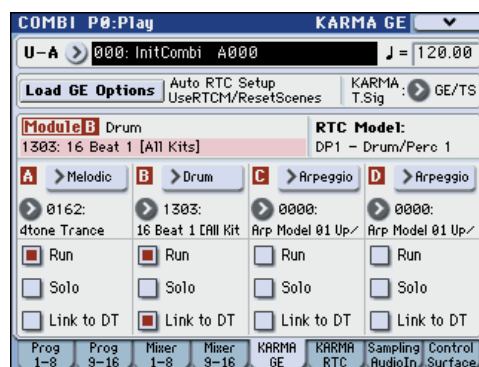

2. Turn on (select) the "Link to DT" setting for the KARMA module(s) that you want to link with the Drum Track pattern start/stop.

When you turn on at least one of the modules A-D, the front panel LINKED LED will light.

*Note:* You can also make this setting using the Prog P7-1: KARMA1- GE Setup A/B/C/D page **Link to DT** (Link To Drum Trk) parameter.

3. When you turn the KARMA ON/OFF switch on and play the keyboard (or receive a note-on), the KARMA modules whose "Link to DT" is off will be triggered, and will start. KARMA modules whose "Link to DT" is on will not be triggered.
4. When you turn the DRUM TRACK ON/OFF switch on, the KARMA modules whose "Link to DT" is on will start at the timing that the drum track starts.

If **Trigger Mode** is set to Start Immediately, KARMA will be triggered when you turn the DRUM TRACK ON/OFF switch on, and will begin operating (if KARMA LATCH is on).

If **Trigger Mode** is set to Wait KBD Trig, it will begin operating when you play the keyboard (or receive a note-on).

If you turn the DRUM TRACK ON/OFF switch off while KARMA is operating, KARMA will also stop if KARMA LATCH is off.

5. Make settings so that the beat will match (synchronize to) the operating KARMA modules.

In the Prog P1: Basic/DT/Ctrl- Drum Track page, turn **Trigger Sync** on.



**6. Make settings so that the KARMA modules will synchronize to the currently-running Drum Track pattern.**

In the P7-2: KARMA2- Trigger A/B/C/D page, turn **Quantize Trigger** on (selected).

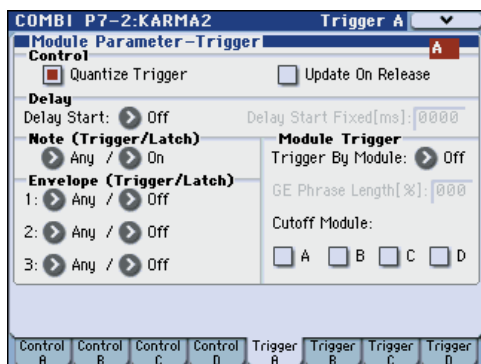

**Specifying whether the drum track will operate for each KARMA scene**

Just as you can in Program mode, you can specify whether the drum track will operate for each KARMA scene in Combination mode and Sequencer mode. These settings are made by the respective P7-1: KARMA1- Scene Matrix page **DT Run** parameter. Refer to the procedure for Program mode (see page 192).

## Synchronizing the Drum Track function

### The Trigger "Sync" parameter

The trigger timing of a drum track will depend on the setting of its Trigger **Sync** parameter.

**On (checked):** The trigger timing will be quantized to the nearest beat relative to the base tempo.

**Off (unchecked):** If **Trigger Mode** is Start Immediately, triggering will occur at the moment you press the DRUM TRACK ON/OFF switch. If this is set to Wait KBD Trig, triggering will occur at the moment you play the keyboard.

### Synchronizing the drum track with the KARMA function, Sequencer mode songs, patterns, and RPPR performance

If you want the Drum Track pattern to play or be recorded in synchronization with the currently-operating KARMA function, currently-playing song, pattern, or RPPR performance, turn **Trigger Sync** on.

**Trigger Sync Off:** If the **Trigger Mode** setting is Start Immediately, the Drum Track pattern will be triggered the moment you press the DRUM TRACK ON/OFF switch. If this is set to Wait KBD Trig, the Drum Track pattern will be triggered the moment you play the keyboard. It will not synchronize to the currently-operating KARMA function or to the currently-playing song, pattern, or RPPR.

**Trigger Sync On:** Triggering will synchronize to the currently-playing song, pattern or RPPR performance in units of a measure. Triggering will synchronize to the currently-operating KARMA function (in Sequencer mode if the song or pattern is stopped) in units of a beat.

*Note:* If you want to synchronize KARMA to the currently-running Drum Track function, set the **Quantize Trigger** parameter (Prog P7-1: KARMA1- Trigger, Combi/Seq P7: KARMA2- Trigger A/B/C/D).

*Note:* If you want to synchronize the RPPR pattern performance to the currently-running Drum Track function, set the **Sync** parameter (Seq P10: Pattern/RPPR- RPPR Setup page) to Beat or Measure.

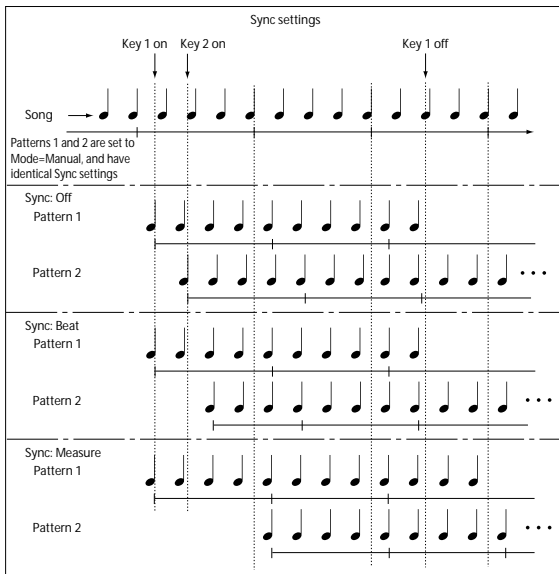

## Synchronization with song stop

### Synchronization with a song in Sequencer mode

- When you press the SEQUENCER START/STOP switch, the Drum Track function will stop as well as the sequencer.
- If you want the Drum Track function to start simultaneously with the beginning of recording, press the DRUM TRACK ON/OFF switch during the pre-count before recording (if **Trigger Mode** is Start Immediately) or play the keyboard (if **Trigger Mode** is Wait KBD Trig). The Drum Tracks will not be triggered immediately, but will be triggered in synchronization with the sequencer the moment recording starts.

## Slave operation

Connect the M3's MIDI IN to your external MIDI device's MIDI OUT, or connect the M3's USB B connector to your computer's USB port.

Set **MIDI Clock** (Global, see PG page 363) to External MIDI or External USB. The M3 will synchronize to MIDI realtime clock and realtime command messages it receives from the connected MIDI device.

*Note:* If the M3 is set to **MIDI Clock**= Auto, it will also synchronize to the external MIDI device in the same way if MIDI realtime clock messages are being received from the external device.

### Synchronization to MIDI clock

The KARMA function will synchronize to a tempo based on the external MIDI clock timing.

### Synchronization with MIDI realtime commands

In Sequencer mode, Song Start, Continue, and Stop messages that the M3 receives will control song playback and recording just as when you operate the front panel START/STOP switch. The KARMA

function also will be controlled in the same way as when you operate the front panel START/STOP switch. (See "Synchronization with song stop")

## Master operation

Connect the M3's MIDI IN to your external MIDI device's MIDI OUT, or connect the M3's USB B connector to your computer's USB port.

Set **MIDI Clock** (Global 1-1a) to Internal. The connected external MIDI device will synchronize to the MIDI realtime clock and realtime commands it receives.

*Note:* The same applies if **MIDI Clock**=Auto and MIDI realtime clock messages are being transmitted. For details, please see "MIDI Clock (MIDI Clock Source)" on page 364 of the Parameter Guide.

### Synchronization via MIDI clock

The connected external MIDI device will synchronize to the MIDI clock of the M3.

## Creating a Drum Track pattern

To create a Drum Track pattern, you'll use the Sequencer mode P10: Pattern/RPPR- Pattern Edit page to convert a user pattern into a user Drum Track pattern. Once you've converted the pattern in this way, you'll be able to use it with the drum track in each mode. These converted Drum Track patterns are held in internal memory even after you turn off the power. This means you can manage them together with the programs and combinations.

## Preparing a user pattern

You'll first need to prepare the user pattern that you want to convert to a Drum Track pattern.

To create a user pattern, you can realtime-record it in the Seq P10: Pattern/RPPR- Pattern Edit page, or step-record it (see page 93, PG page 265).

Alternatively, performance data from a track can be imported into a pattern, meaning that performance data you've created in a track or SMF data you've loaded in Media mode can be used as a user pattern. To do this, execute the **Get From Track** menu command in the Seq P10: Pattern/RPPR- Pattern Edit page (see PG page 265).

## Converting to a Drum Track pattern

1. Press the MODE SEQ switch to enter Sequencer mode.
2. Access the Seq P10: Pattern/RPPR- Pattern Edit page.

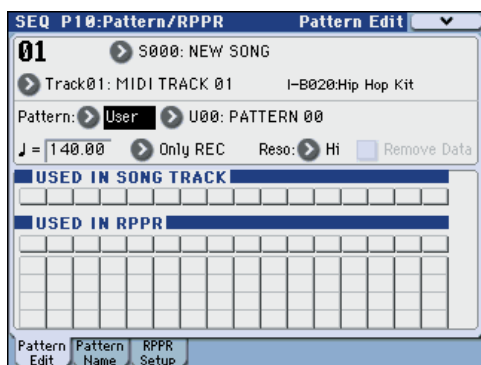

3. Select the user pattern that you want to convert to a Drum Track pattern.

Set **Pattern** to User, and use **Pattern Select** to select the desired pattern.

4. Choose the menu command **Convert to Drum Trk Pattern** to access the dialog box.

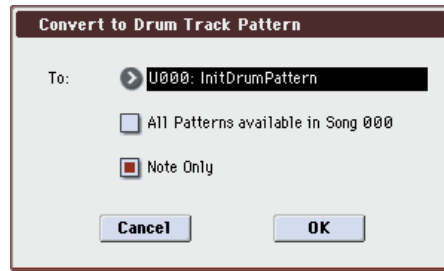

5. Use the To "Drum Track Pattern Select" field to specify the user Drum Track pattern number that will hold the converted data. When you execute the command, the data will be overwritten onto this number.
6. If you select the "All Patterns available in Song \*\*\*" option, all patterns in the song that contain note data will be converted, starting with the number you specified in step 4.
7. If you execute this command with "Note Only" selected, only the note events will be converted.
8. Press the OK button or the ENTER switch to execute. If you decide not to execute, press the Cancel button or the EXIT switch.
9. As described in "Using the Drum Track function in Program mode" on page 185, set the Drum Track "Pattern Bank" to User, and set "Pattern No." to the user Drum Track pattern you converted. Then play the Drum Track pattern.

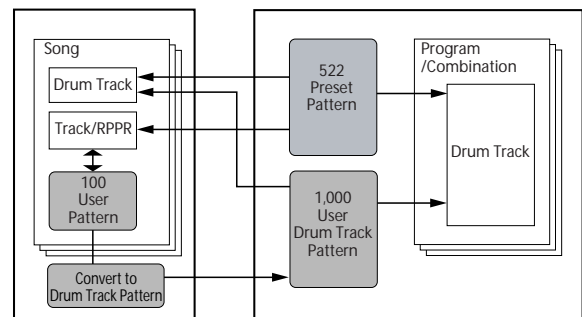

Sequencer memory  
(Not saved internally;  
save on external USB  
media.)

Internal memory (saved inside the M3)





# Other functions common to all modes

## Editing names

You can modify the name of an edited program, combination, song, drum kit, multisample or sample etc.

You can also modify the category names for programs and combinations.

These renaming operations can be performed in the following pages.

Item	Page
Program	Prog P0...9 menu command: Write Program
Combination	Combi P0...9 menu command: Write Combination
Song	Seq P0...5 menu command: Rename Song
Track	Seq P6: Track Name
Pattern	Seq P10: Pattern Name
Cue list	Seq P11: menu command: Cue List
Multisample	Sampling P0...4 menu command: Rename MS
Sample	Sampling P0...4 menu command: Rename Sample
Program category/ sub category	Global P4: Program Category
Combination category/ sub category	Global P4: Combination Category
KARMA GE category/ sub category	Global P4: GE Category
Drum Kit	Global P5 menu command: Rename Drum Kit
File	Media Save: Save All...Save Audio CD Track List, Media Utility menu command: Rename Prog, Combi, Seq, Sampling P0 menu command: Select Directory
WAVE Parameter	Media Edit WAVE menu command: Save WAVE Parameter
Effect preset	Prog, Combi, Seq, Sampling P8, 9 menu command: Write FX Preset

1. In the pages listed above, or after selecting a menu command in these pages, press the text edit button **T** to access the text edit dialog box.

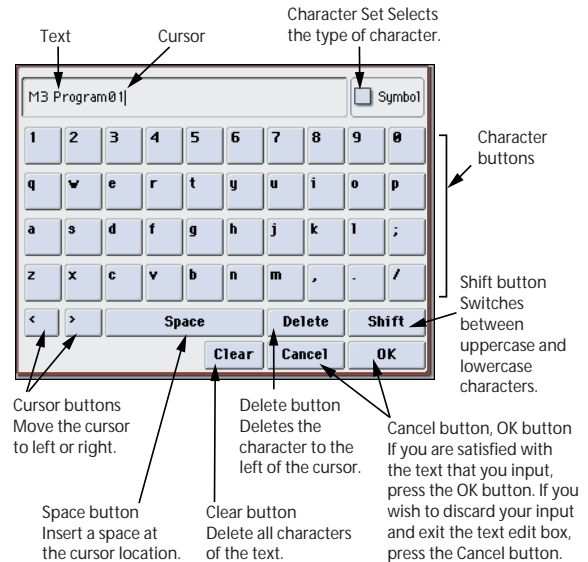

2. We'll use "M3 Program01" as an example.

- Press the Clear button.
- Press the Shift button to switch to uppercase characters, and press M.
- Press the Shift button once again to switch to lowercase characters, and press the characters 3.
- Press the Space button.
- Press the Shift button to switch to uppercase characters, and press P.
- Press the Shift button to switch to lowercase, and enter the remaining characters.

*Note:* In Media mode, there are some limitations on the characters that can be entered.

3. Press the OK button to close the dialog box.

You will return to the page in which you were before accessing the text edit dialog box.

## Setting the functions of SW1 and SW2

SW1 and SW2 are the two switches above the joystick and ribbon.

These on/off switches can perform a number of different functions, such as modulating sounds or effects, or locking the modulation values of the joystick, ribbon, or aftertouch.

Also, each one may work either as a toggle, or as a momentary switch. In **Toggle** mode, each press alternates between on and off; in **Momentary** mode, the switch only changes for as long as you hold it down.

Each Program, Combination, and Song stores its own settings for what the switches will do, and whether each switch is on or off (based on their current states when the data is saved). You can also make settings for Sampling mode as a whole.

You can set up Panel Switch Assign on the Controllers Setup or Setup page.

Mode	Page
Programs	Prog P1: Basic/DT/Ctrls
Combinations	Combi P1: DT/XY/Ctrls
Songs	Seq P1: DT/XY/Ctrls
Sampling mode	Sampling P4: Controllers

An example of settings in a Program

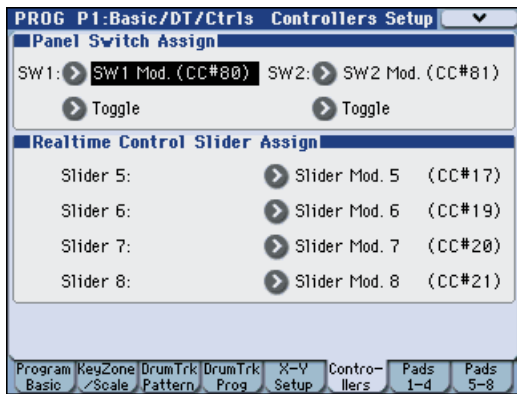

When using SW1/2 for AMS or Dmod, the default settings are SW1 Mod.(CC#80) and SW2 Mod.(CC#81).

For an example, see “Using Dmod to change the feedback level via SW1” on page 161. For a complete list of the possible assignments, see “SW1/2 Assignments” on page 597 of the Parameter Guide.

*Note:* If you wish to keep these settings after the power is turned off, you must save the Program, Combination, or Song. Note that the settings for Sampling mode cannot be saved.

## Setting the functions of Realtime Controls Slider 5–8

When the Control Surface **CONTROL ASSIGN** is set to **REALTIME CONTROL**, the four sliders on the right function as Realtime Sliders 5–8 (User 1–4).

These can perform a number of different functions, such as modulating sounds or effects, adjusting effects send levels, and so on.

Each Program, Combination, and Song stores its own settings for what the sliders will do. You can also make settings for Sampling mode as a whole.

When using the sliders for AMS or Dmod, it’s important to understand that assignment is a two-step process. First, you assign the slider to send a MIDI controller, such as Slider Mod.1 (CC#17). Second, you assign that MIDI controller to modulate one or more Program or effects parameters.

For the first part of the above, use the mode’s **Controllers Setup** or **Setup** page. (See “Setting the functions of SW1 and SW2,” above)

The default assignments for Sliders 5–8 are Slider Mod.5 (CC#17), Slider Mod.6 (CC#19), Slider Mod.7 (CC#20), and Slider Mod.8 (CC#21), respectively. For a complete list of the possible assignments, see “Realtime Control Slider 5–8 Assignments” on page 598 of the Parameter Guide.

Here’s an example of how to set up Slider 5 (User 1) to control a Program’s filter and amp EG attack time:

1. Press the **MODE PROG** switch to enter **Program mode**.
2. Access the **P1: Basic/DT/Ctrls– Controllers Setup** page.

Press the **PAGE SELECT** switch to access Page Select, and choose “P1 Basic/DT/Ctrls.”

3. Press the **Realtime Control Slider Assign “Slider 5”** popup button, and choose **F/A Attack (CC#73)**.
4. Press the **CONTROL ASSIGN REALTIME CONTROL** switch. (the LED will light)
5. Operate slider 5 (**USER 1**) to control the EG attack for the filter and amp.

*Note:* If you wish to keep these settings after the power is turned off, you must save the Program, Combination, or Song (see page 140). Note that the settings for Sampling mode cannot be saved.

## Using tap tempo

You can set the tempo of the KARMA function or Drum Track function in Program, Combination, and Sequencer modes by lightly pressing the TAP TEMPO switch several times in succession. In Sequencer mode, you can control the song tempo in this way.

In Sampling mode, you can set **Grid** to the desired BPM value by lightly pressing the TAP TEMPO switch while the sample plays back.

To enter the tempo, use your finger to gently tap the TAP TEMPO switch. The tempo will be entered when you press the switch twice, but you should tap several times in order to increase the precision. The average of the last sixteen taps will be specified as the tempo.

During playback, lightly press the TAP TEMPO switch several times at the desired tempo. The tempo will follow your tapping in realtime. This is a convenient way to match the tempo in realtime to the beat of a different source.

As an example, here's the procedure for using tap tempo to set the speed of the KARMA.

### 1. In Program mode or Combination mode, start the KARMA function running.

Turn on the KARMA ON/OFF switch, and play a key or a pad. (If you press the LATCH switch, the KARMA function will continue playing even after you take your finger away.)

### 2. Lightly press the TAP TEMPO switch several times at the desired tempo.

Notice that the “♩=” in the upper right of the display will change to indicate the tempo at which you press the TAP TEMPO switch.

If you press the TAP TEMPO switch at slightly shorter intervals, the playback tempo will become correspondingly faster.

 You can use tap tempo control whenever the TEMPO knob can be operated. For example in Sequencer mode, tap tempo control will not be available if you are playing a song whose **Tempo Mode** setting is set to Auto. (See PG page 196)

*Note:* You can also use a foot switch connected to the ASSIGNABLE FOOT SWITCH jack to control the tap tempo function (see page 132, PG page 599).

## Resetting controller values

The controllers of the control surface can be reset or switched to stored values.

If you want to reset a controller individually, hold down the RESET CONTROLS switch and operate the control surface slider, or switch that you want to reset.

If you want to reset all of the control surface sliders, and switches in a CONTROL ASSIGN unit (a tab within the Control Surface page) in a single operation, hold down the RESET CONTROLS switch and press the corresponding CONTROL ASSIGN switch.

### CONTROL ASSIGN MIXER & MODULATION

You can use the front panel RESET CONTROLS switch to reset the desired slider or switch, or the entire group of CONTROL ASSIGN settings.

Here's how to reset an individual slider or switch.

1. **While holding down the RESET CONTROLS switch, operate the slider 1–8 or switch 1–8 that you want to reset.**
2. **When you've reset the controller, release the RESET CONTROLS switch.**

Here's how to reset an entire group (CONTROL ASSIGN) of sliders or switches.

- While holding down the RESET CONTROLS switch, press the CONTROL ASSIGN MIXER–KARMA switch that's shown in the display (i.e., whose LED is lit).

The program or combination will be reset to the values that are written. For a sequencer song, the values will be reset to the state in which you entered the mode or selected the song, or the state immediately after you executed **Copy From Combi**, etc.

*Note:* When you reset CONTROL ASSIGN REALTIME CONTROL, each slider will be at the center value (064).

*Note:* For CONTROL ASSIGN TONE ADJUST, the values will be reset as follows depending on the parameters that are assigned.

For a program, absolute-type values will be reset to the specified value and relative-type values will be reset to the center.

For a combination, the values will be reset to the written values. For a sequencer song, the values will be reset to the state in which you entered the mode or selected the song, or the state immediately after you executed **Copy From Combi**, etc.

### KARMA MODULE CONTROL switch

- You can reset the sliders, switches, and scene settings of the currently-lit KARMA module. While holding down the RESET CONTROLS switch, press the KARMA MODULE CONTROL switch to reset these settings.

### KARMA SCENE 1/5–4/8 switches

- You can reset a KARMA scene by holding down the RESET CONTROLS switch and pressing the SCENE 1/5–4/8 switch whose LED is blinking.

If you once again hold down the RESET CONTROL switch and press the SCENE 1/5–4/8 switch whose LED is lit, it will return to the blinking state.

For a program or combination, the settings will be reset to the values that are written. In Sequencer mode, the settings will be reset to the state in which you entered the mode or selected the song, or the state immediately after you executed **Copy From Combi**, etc.

---

## Shortcuts

### ENTER switch + numeric keys 0–9

- Accesses the menu commands in each page (up to ten items)

### ENTER switch + REC/WRITE switch

- Accesses the Auto Song Setup function. In Program or Combination mode you can press this combination of keys to automatically assign the settings of the program or combination to a song in Sequencer mode, and then enter record-ready mode.

### ENTER switch + keyboard

- Inputs note number values or velocity values
- Selects “KEY” in Global P5: Drum Kit, Seq P10: Pattern/RPPR, RPPR Setup page
- Selects base key and index in Sampling mode

*Note:* While a dialog box is displayed, the ENTER switch will perform the same function as the OK button. This means that you can't use this method to enter a note number or velocity value in a dialog box that contains an OK button.

### ENTER switch + LOCATE switch

- In Sequencer mode, sets the current location as the “Location” (equivalent to the **Set Location** menu command)

### CONTROL ASSIGN KARMA switch (the LED will light) + KARMA MODULE CONTROL switch

In Combination or Sequencer mode, sets Module Control to Master. (This is the same operation as selecting Module Control = M in P0 Control Surface “Control Assign” KARMA.)

### ENTER switch

While a dialog box is displayed, this switch performs the same operation as the OK button.

### PAGE SELECT switch + numeric key 0–9

By holding down the PAGE SELECT switch and pressing a numeric key 0–9 you can jump to the corresponding page.

*Note:* In pages that contain multiple sub-pages, the first page (e.g., P3–1 or P7–1) will be selected.

### EXIT switch

This button makes it easy to return to the main page of the current mode:

1. **Press it once to go to the previously-selected tab on the main P0 page.**
2. **Press the EXIT switch. You will move to the previously-selected parameter of the P0 top page (Prog: Main, Combi/Seq: Program T01–08).**
3. **Press the EXIT switch. You will move to the first tab of the P0 top page, and the corresponding parameter will be selected.**

From any page, you need only press the EXIT switch a maximum of three times to be able to select a Program, Combination, or Song using the numeric keys or  $\Delta/\nabla$  switches.

### EXIT switch (in dialog boxes)

When a dialog box is displayed, this has the same function as the Cancel, Done, or Exit button.

### From a powered-off condition, turn on the power while holding down the RESET CONTROL switch + (control surface) 1+2

- Initializes the M3, and writes data into internal memory. (A message of “Now writing into internal memory” will appear in the display while the data is being loaded.)

After initialization, you will need to load the pre-load data. Execute the Global mode menu command **Load Preload/Demo Data** to load the data. (See PG page 382)



# Appendices

## Restoring the factory settings

### Loading the preloaded data

The original preload data is backed up in the M3 and can restore any or all of the Programs, Combinations, Drum Kits, and Global settings to their original factory settings. The original demo songs can also be re-loaded at any time using this same method.

This is done by re-loading the preload data stored within the M3.

- ⚠ Never turn off the power while the data is being loaded.
- ⚠ Before you load the preload data, go to the Global mode P0: Basic Setup– System Preference page, and uncheck the “Memory Protect” settings for the data that you want to load. If you execute this operation with these settings checked, and the data will not be loaded.
- ⚠ Loading the preloaded data will overwrite the data in internal memory. If you want to keep the data that is currently in internal memory, use “Save All” or “Save PCG” to save it to external media before you continue.

#### 1. Access the Global mode P0: Basic Setup– Basic page.

Press the MODE GLOBAL switch to enter Global mode.

If the Global P0: Basic Setup– Basic page is not shown, press the EXIT switch.

#### 2. Press the menu button, and choose “Load Preload/ Demo Data.”

A dialog box will appear.

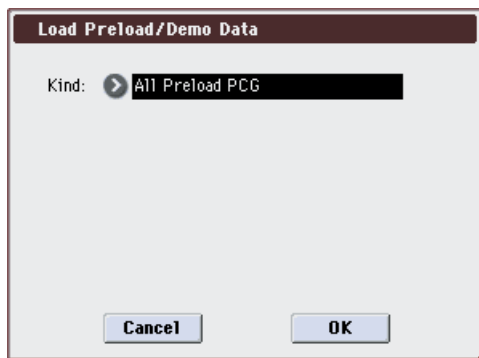

#### 3. In the “Kind” field, select All Preload PCG.

In addition to All Preload PCG, you can also select :

- All (Preload PCG and Demo Songs)
- All Demo Songs
- Program
- Combination
- Drumkit
- Global Setting

*Note:* Program, Combination and Drumkit can load all, a single bank, or an individual item

#### 4. Press the OK button to execute the load operation. If you decide not to execute, press the Cancel button.

When you press the OK button, a dialog box will ask you for confirmation. Press the OK button to execute loading.

*Note:* While a dialog box is displayed, the ENTER switch will perform the same function as the OK button.

### About the data loaded by All Preload PCG

When you execute All Preload PCG, the following data will be loaded. When you execute All (Preload PCG and Demo Song), the Demo Song data will be loaded in addition to the data of All Preload PCG.

If the EXB-RADIAS is installed, programs will be loaded into bank I–F.

#### If the EXB-RADIAS is not installed

- Program:  
Bank I–A, I–B, I–C, I–D
- Combination: Bank I–A, I–B, I–C
- Drum Kit: 000(INT)...031(INT)
- Global Setting
- Demo Song: S000–S003  
Only when executing All (Preload PCG and Demo Song)

*Note:* Demo song data will be erased when the power is turned off.

#### If the EXB-RADIAS is installed

In addition to the above data, the following items will also be loaded.

- Program: Bank I–F
- Formant Motion 1–16

For details, please see “EXB-RADIAS for M3 Manual” (PDF).

## Installing options

Please read this before you begin installation

### Safety precautions

#### Warning

- Before installing an option, be sure to disconnect the power supply cable and the connecting cables to any peripheral devices. Failure to do so could cause electrical shock or may damage the device.
- When installing, repairing, or replacing an option, you must perform only those actions that the owner's manual directs, and no other.
- Do not apply excessive force to the electronic components or connectors on the circuit board(s) of an option, or attempt to disassemble them. This could cause electric shock, fire, or malfunction.

#### Caution

- Before touching the option, touch a metal component of the device into which it will be installed, to discharge any static electricity that may be present in your body. Static electricity may damage the electronic components.
- Danger of explosion if battery is incorrectly replaced. Replace only the same or equivalent type.
- When handling an option, never touch parts that are not related to the installation. Doing so may cause electrocution or malfunctions.
- When handling an option, be careful not to touch the leads on the back side of the circuit board (the side opposite that on which the components are mounted). The sharp points may cause injury.
- Do not allow the option or other device being installed to become wet, and do not allow objects to be placed on top of it. Doing so could cause malfunction.
- When installing an option, be careful that screws or other parts do not fall into the device into which it is being installed. Doing so could cause malfunction.

Korg Inc. takes no responsibility for any malfunctions or damage that may occur from improper use or modification of this product. Nor will Korg Inc. be responsible for any damages resulting from the loss or destruction of data.

## Cautions when installing an option board

In order to install the board correctly, please pay attention to the following points.

Be careful of static electricity, which may damage components inside the product or on the board. Before beginning the installation, touch an unpainted metal part of the chassis or the grounding terminal of a grounded device to discharge any static electricity that may be present in your body.

Perform the installation according to the steps given in the directions, making sure that the board is installed correctly and in the correct orientation.

When installing or removing the board, be careful not to drop parts or the option board into the instrument.

Handle the board with care. Subjecting it to physical shock (by dropping or pressing it) may cause damage or malfunctions.

Be careful not to touch any exposed metal portions of the circuit board, or any parts that are not essential to the installation process.

## Available option boards for the M3

You can enhance the M3's capabilities by installing any or all of the following options.

### ● EXB-RADIAS (RADIAS Synthesizer Board)

Based on the MMT (Multiple Modeling Technology) synth engine that powers the RADIAS and R3, the EXB-RADIAS synthesizer/vocoder option provides up to 24 voices of polyphony and offers a wide range of tonal variations.

### ● EXB-FW (FireWire Board)

The EXB-FW FireWire Interface allows you to transmit both MIDI and Audio messages to and from your computer. The EXB-FW also allows the M3 to behave as a virtual instrument (Virtualized Hardware) by using the M3 Plug-In Editor inside a host application. The EXB-FW provides two FireWire connectors so that you can daisy-chain compatible devices.

### ● EXB-M256 (Sample Memory Expansion)

You can expand the user sample memory by installing this dedicated 256MB (megabyte) memory board in your M3.

## Calendar battery

### ● Calendar battery

The calendar battery maintains the time and date that are recorded each time you save data. The M3 uses a CR2032 battery.

### CR2032 batteries that are compatible with the M3

- CR2032 batteries made by Sony or Panasonic

## Verifying installation

When you power-on the M3, the display will show the option boards and memory that are currently installed.



After installing memory or an option board, you must turn on the power and verify that the name of the item you installed is shown in the display.

**EXB-RADIAS:** The EXB-RADIAS is installed.

**EXB-FW:** The EXB-FW is installed.

**EXB-M256:** The EXB-M256 is installed.

If it is not shown, the item may not have been installed correctly. Check once again to ensure that the item is correctly installed.

## Servicing the calendar battery

If the calendar battery is not installed correctly, or if the battery voltage is too low, the following message will appear in the display when you turn on the power.

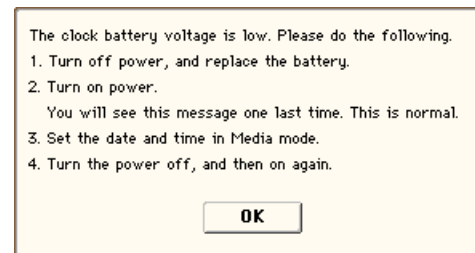

Make sure that you are not using a battery that has run down, and that the battery is installed correctly.

However, please be aware that this message will also appear the first time you turn on the power after replacing the calendar battery.

If you have any questions regarding installation, please contact Korg customer service.

## Installing the options and replacing the calendar battery

Before you proceed, please read the preceding "Safety cautions" and "Cautions when installing option boards or memory." The sound module must be removed from the keyboard assembly in order to perform these procedures. For details on how to remove the sound module, please see the "Keyboard assembly Manual."

You will need a Phillips (+) screwdriver and a cushioned surface to protect the sliders and knobs from damage. You can also use a stack of magazines (or the equivalent). Place the magazines at the four corners of the sound module to protect the sliders and knobs from damage, and place the sound module face down on them.

- ⚠ You must leave the AC power cable disconnected until you've finished the entire installation process.
- ⚠ Be careful not to cut your hand on any metal parts of the sound module or option board.

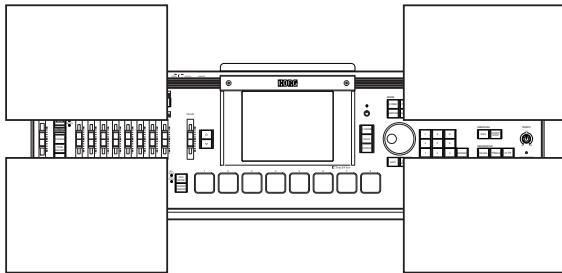

View from below

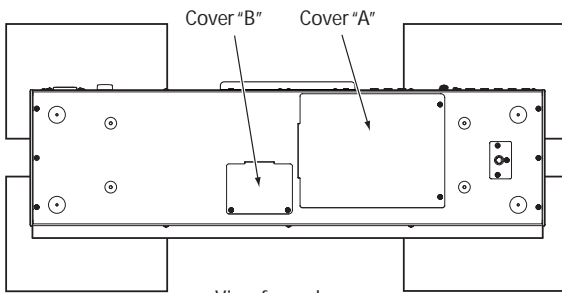

View from above

### Installing the EXB-RADIAS

- ⚠ If you are installing the EXB-FW and EXB-RADIAS at the same time, install the EXB-FW first.

1. Use your Phillips (+) screwdriver to remove the two screws from cover "A," and remove cover "A" from the sound module.

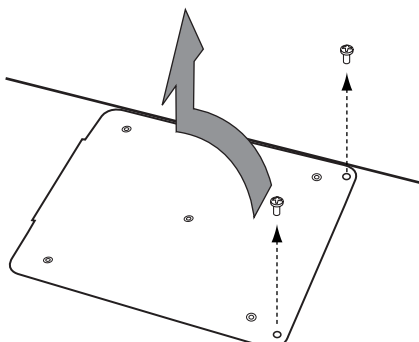

2. Make sure that the EXB-RADIAS is oriented correctly, and use the five screws to fasten it to the back of cover "A."

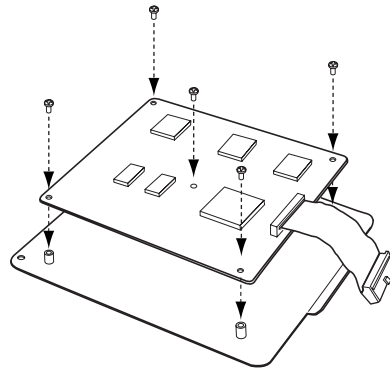

3. Connect the cable of the EXB-RADIAS to the connector of the sound module as shown below.

- ⚠ Firmly push the cable all the way in so that it does not contact anything other than the connector on the circuit board.

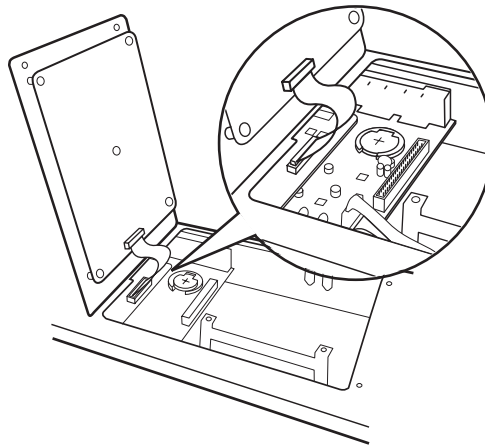

4. Attach cover "A" to the sound module.

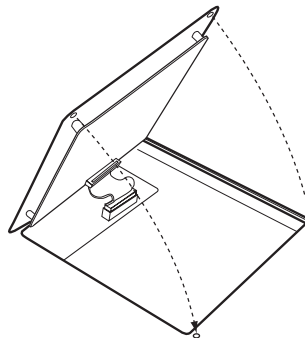

5. Fasten cover "A" using the two screws you removed in step 1.

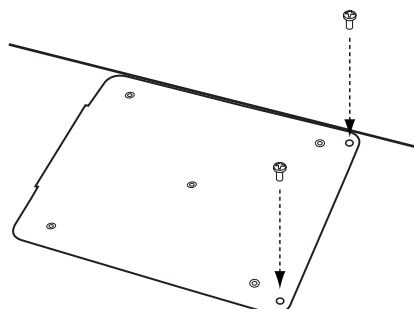



6. When you've finished the entire procedure, turn on the power and verify that the EXB-RADIUS was installed correctly. (See "Verifying installation" on page 203)

7. Load formant motion data data in Global mode.

Refer to the procedure in "Loading the preloaded data" on page 201. When you execute this procedure, change step 3 so that instead of selecting "Kind" All Preload PCG, you select RADIUS Formant Motion Data and All. (Alternatively, refer to "Restoring the formant motion data to the factory-set state" (see page 18) in "EXB-RADIUS for M3 Owner's manual.")

## Installing the EXB-FW

Before you proceed with installation, please read the preceding "Safety cautions" and "Cautions when installing option boards or memory."

-  You must leave the AC power cable disconnected until you've finished the entire process of option board installation.
-  Be careful not to cut your hand on any metal parts of the sound module or option board.

1. Remove cover "A" as described in step 1 of "Installing the EXB-RADIUS."

-  If the EXB-RADIUS is already installed, carefully lift up cover "A" and temporarily disconnect the EXB-RADIUS connector cable.

2. Using your Philips (+) screwdriver, remove the two screws from the FW cover that blocks the sound module's rear panel openings for the EXB-FW, and remove the FW cover. The two screws you removed will later be used to fasten the EXB-FW.

-  Be sure to remove the FW cover from the sound module; don't leave it inside. Keep the FW cover in a safe place in case you need to remove the EXB-FW.

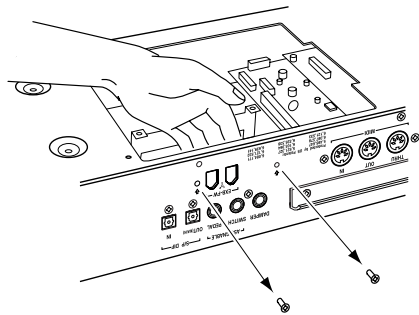

3. Verify the location in which you'll be installing the EXB-FW, and align it so that the connector section of the EXB-FW protrudes from the rear panel of the sound module.

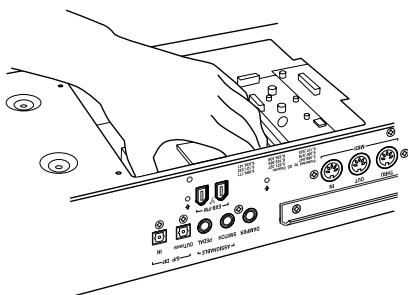

4. Tighten the two screws attached to the EXB-FW to firmly fasten it to the sound module.

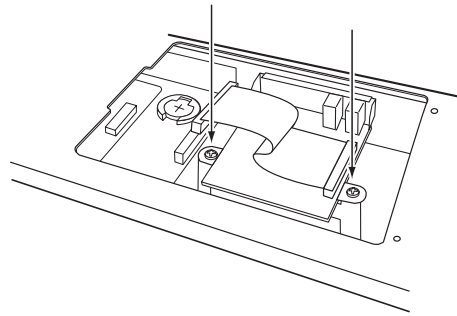

5. Tighten the two screws you removed in step (2) to fasten the EXB-FW to the rear panel of the sound module.

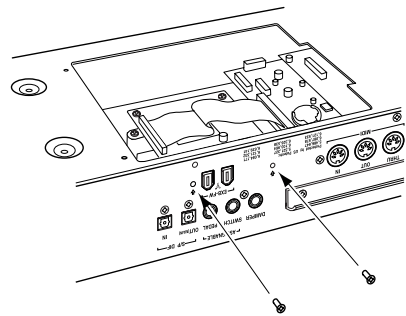

6. Attach the cable as shown in the illustration. Firmly insert the cable as far as it will go.

-  Be careful not to touch anything other than the connector of the circuit board to which you're connecting the cable.

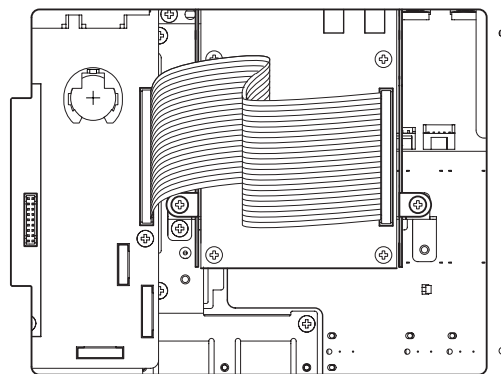

7. Attach cover "A" to the sound module as described in steps 4-5 of "Installing the EXB-RADIUS."

8. When you've finished the entire procedure, turn on the power and verify that the EXB-FW was installed correctly. (See "Verifying installation" on page 203)



## Installing the EXB-M256

Before you proceed with installation, please read the preceding “Safety cautions” and “Cautions when installing option boards or memory.”

- ⚠ You must leave the AC power cable disconnected until you’ve finished the entire process of option board installation.
- ⚠ Be careful not to cut your hand on any metal parts of the sound module or option board.
- ⚠ The EXB-M256 can be used only with compatible products manufactured by Korg. It is not compatible with conventional computers. Also, using a commercially available memory board as a substitute for the EXB-M256 will cause malfunctions. Please use the correct product only as directed.

1. Using your Phillips (+) screwdriver, remove the two screws from cover “B,” and then remove cover “B” from the sound module.

- ⚠ Don’t lose the screws that you remove.

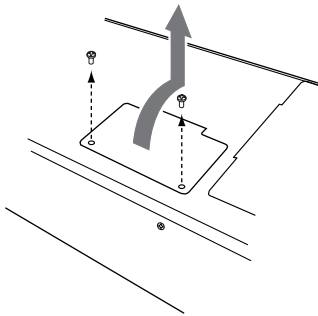

2. Verify the location in which you’ll be installing the EXB-M256.

Making sure that the EXB-M256 is oriented correctly, insert it diagonally into the slot of the sound module as shown in the illustration, inserting it as far as it will go.

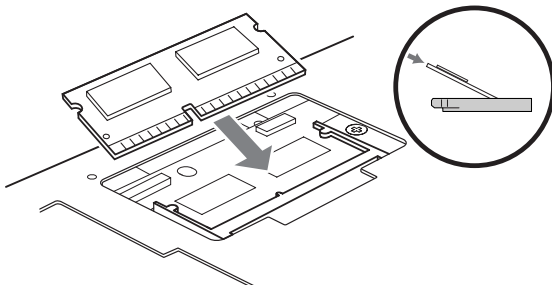

3. As shown in the illustration, gently press down the EXB-M256 so that it lies flat. When the EXB-M256 clicks into place, locking tabs will hold it in place.

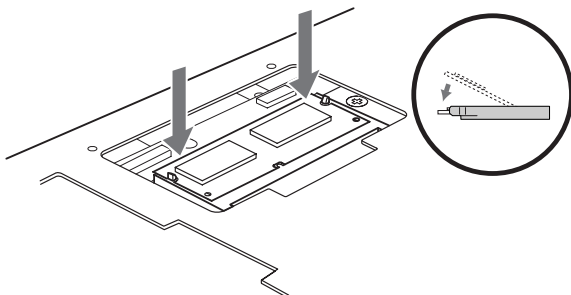

4. Attach cover “B” to the sound module, and fasten it using the two screws you removed in step (2).

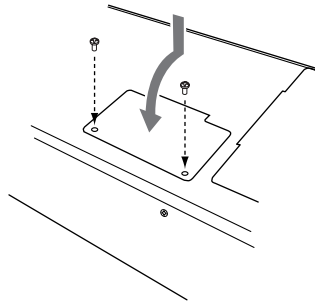

5. When you’ve finished the entire procedure, turn on the power and verify that the EXB-M256 was installed correctly. (See “Verifying installation” on page 203)

## Removing the EXB-M256

Before you proceed, please read the preceding “Safety cautions” and “Cautions when installing option boards or memory.”

- ⚠ You must leave the AC power cable disconnected until you’ve finished the entire process of option board installation.
- ⚠ Be careful not to cut your hand on any metal parts of the sound module or option board.

1. Remove cover “B” from the sound module as described in steps 1–2 of “Installing the EXB-M256.”

2. Spread the locking tabs to left and right until the EXB-M256 pops up into a diagonal position.

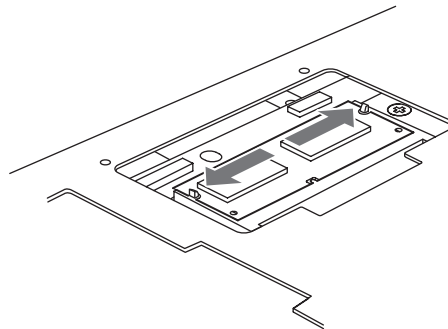

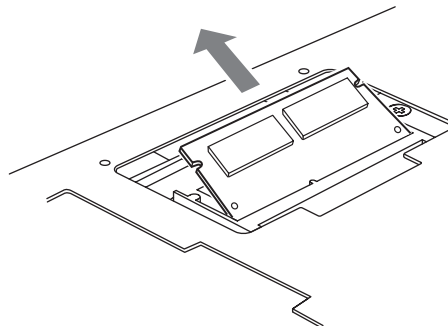

3. Pull the EXB-M256 straight out and remove it from the slot.



4. Re-attach cover “B” as described in step 5 of “Installing the EXB-M256.”

## Replacing the calendar battery

Before you proceed, please read the preceding “Safety cautions” and “Cautions when installing the calendar battery.”

-  Be careful not to cut your hand on any metal parts of the sound module or option board.
-  You must leave the AC power cable disconnected until you’ve finished the entire process of installing the calendar battery.

If you turn on the power when the calendar battery voltage is low, the following message will appear in the display. Please install a fresh battery.



1. Remove cover “A” as described in step 1 of “Installing the EXB-RADIUS.”
2. Verify the location in which you’ll be installing the calendar battery.

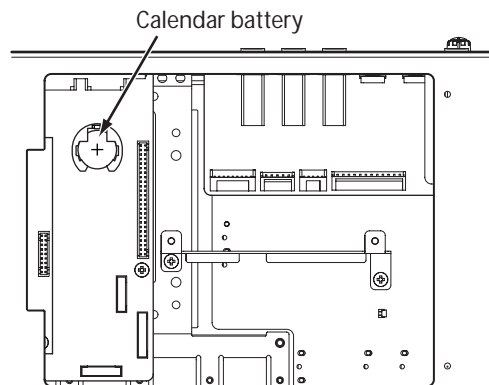

With cover “A” removed

### 3. Remove the old calendar battery.

Press the battery in the location shown in the illustration below, free it from the battery holder tab, and lift the battery out to remove it.

-  Be careful not to drop the battery into an opening in the unit.

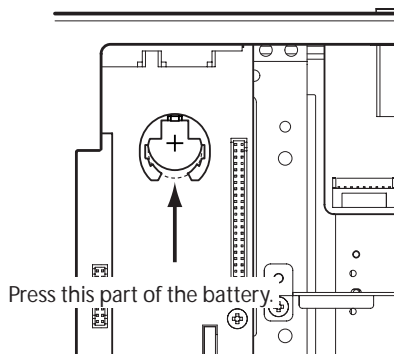

### 4. Insert the new battery.

With the “+” surface of the calendar battery facing upward, insert it diagonally into the battery holder.

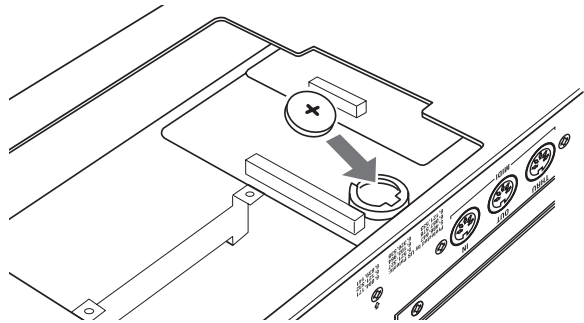

### 5. Attach cover “A” to the sound module as described in steps 4–5 of “Installing the EXB-RADIUS.”

### 6. When you’ve finished the entire procedure, turn on the power.

The message shown earlier will appear in the display once again, but this is normal.

Go to Media mode and set the correct date and time. (See “Setting the date and time” on page 148)

### 7. This completes the procedure, but to ensure that the calendar battery was installed correctly, turn off the power, and wait a few seconds.

Then turn on the power again, and verify that the message shown in the illustration at the upper left does not appear.

## Troubleshooting

If you experience problems, please see the relevant item and take the appropriate measures.

---

### Power supply

#### Power does not turn on

Is the power cable connected to an outlet? → p.26

Is the rear panel POWER switch turned on? → p.25

---

### Display

The power is turned on, but nothing is shown on the display. The M3 functions normally when you play the keyboard or perform other operations.

Use the rear panel Contrast adjustment knob to adjust the contrast of the display. → p.12

The power is turned on, but the display does not work normally, or an error message is displayed. There is no sound when you play the keyboard, and the M3 does not function normally.

This type of problem may occur if a data writing operation to internal memory was not completed correctly, for example if the power of the M3 was turned off while a program or other data was being written. If this occurs, use the following procedure to initialize the M3's internal memory.

1. Turn off the power.
2. While holding down the RESET CONTROLS switch and the 1 and 2 switches located beside it, turn on the power of the M3.

The M3 will be initialized, and data will be written into internal memory. While the data is being written, the display will indicate "Now writing into internal memory."

After initialization, all user data will be empty, and you will need to re-load the preload data. Execute the Global mode menu command **Load Preload/Demo Data** to load the data. → p.201

#### Can't operate the display correctly

On the Global P0: Basic Setup page, use the **Touch Panel Calibration** menu command to adjust the touch panel response. → PG p.383

*Note:* If you are unable to select commands from the menu, do the following:

1. Press the GLOBAL switch.
2. Press the EXIT switch twice.
3. Hold down the ENTER switch and press 4 on the numeric keypad.

The Touch Panel Calibration page will appear. Follow the on-screen instructions to re-calibrate the touch panel.

#### Can't switch modes or pages

If you're doing any of the following, you may not be able to change modes or switch to a different page:

- Recording or playing back a song or pattern
- Sampling, alternatively, are you in sampling-standby mode?
- Playing a CD
- Playing a WAVE file

#### In Combination, or Sequencer modes, can't edit the value of Timbre/Track parameters such as MIDI Channel or Status

Some parameters can't be edited while notes are playing, either locally or from MIDI. If the damper pedal is held down, or if its calibration is incorrect, notes may be sustaining even if they aren't audible.

- Are you using a damper pedal with a polarity that does not match the **Damper Polarity** setting (Global P2: Controllers- Foot Controllers)? → PG p.371
- In some cases, this problem can be solved by executing the menu command **Half Damper Calibration** (Global P0: Basic Setup). → PG p.383

#### No beep sounds when you touch the display

Check the **Beep Enable** check box (Global P0: Basic Setup- System Preference). → p.130, PG p.359

---

## Audio input and output

### No sound

Are connections made correctly to your amp, mixer, or headphones? → p.26

Is the connected amp or mixer powered-on, and is its volume raised?

Is Local Control turned on?

- In Global P1: MIDI, check the **Local Control On** check box. → PG p.363

Is the VOLUME MAIN slider raised? → p.13

Is the Master Volume assigned to **Foot Pedal Assign**, and is that pedal volume lowered? → p.132

Is the X-Y control be controlling volume, and is the HOLD switch on (the LED will light) with the volume lowered? → p.43

Even if the HOLD switch is off (the LED will dark), there may be no sound if the center volume setting is zero.

If there is no sound from the AUDIO OUTPUT (INDIVIDUAL) 1-4 jacks, make sure that **Bus Select** or **Bus** (Bus Select) following the insert effect is set to 1-4, or 1/2-3/4. → p.155, p.158

If a specific timbre doesn't sound in Combination mode, is its Play/Mute button set to Play? Alternatively, are all Solo settings turned off? → p.69

If a specific track doesn't sound in Sequencer mode, is its Play/Rec/Mute button set to Play? Alternatively, are all Solo settings turned off? → p.82

Make sure that the **Status** is INT or BTH. → p.73, p.83

Are the Key Zone and Velocity Zone set so that sound will be produced when you play? → PG p.27, p.77, p.153, p.161, p.231, p.244

Is the Oscillator, Drum Track, Timbre, or Track level lowered in the control surface mixer? → p.47

### Audio inputs don't work properly

Are the appropriate sources connected to the AUDIO INPUT 1, 2 jacks, or the S/P DIF IN jack? → p.28

If there is no sound in Sampling mode, check that **Bus Select**, and **Level** are set correctly in the Sampling P0: Recording– Audio In/Setup page. → p.112

Alternatively, is SAMPLING REC turned on?

If there is no sound in Program, Combination, and Sequencer modes, check that **Bus Select**, and **Level** are set correctly in Global P0: Basic Setup– Audio page; or in the P0: Play(/REC) Sampling/Audio In pages of Program, Combination, or Sequencer modes. → p.123, p.159

Is **Use Global Setting** set correctly? → PG p.9, p.128, p.201

If you are inputting sound to the AUDIO INPUT 1 and 2 jacks, make sure that the AUDIO INPUT LEVEL knob is raised. → p.16, p.112

If you are inputting sound to the AUDIO INPUT 1 and 2 jacks, is the MIC/LINE switch set appropriately? → p.16, p.112

Is an unsupported format being input from the S/P DIF IN jack?

- Please connect an instrument or digital audio device that is compatible with CP-1201 or S/P DIF.

Is the correct sampling frequency being input from the S/P DIF IN jack?

- Sampling frequencies of 48 kHz can be input. If you input an unsupported sampling frequency, noise will occur or a message of "S/P DIF CLOCK ERROR!" will be displayed.

Digital audio input is sometimes not heard for two or three seconds.

### Can't hear an audio CD in a USB CD-R/RW drive connected to AUDIO INPUT

Make sure that you have selected the Media mode Play Audio CD page or Sampling mode.

Is the output of the audio CD being input correctly?

- If you want to monitor the audio, connect the audio output jacks (or headphone jack) of your USB CD-R/RW drive to the M3's AUDIO INPUT 1,2. Alternatively, connect the S/P DIF OUT jack of your USB CD-R/RW drive to the M3's S/P DIF IN jack.
- Set **Input** to Analog or S/P DIF according to the input you're using, and set the **Level** and **Bus Select** appropriately. These parameters are set in

the Media mode Play Audio CD page or the Sampling mode Audio In/Setup page. → PG p.351, p.395

- Is the **Volume** slider raised? (Media mode Play Audio CD page, Sampling P5: Audio CD– Ripping page) → PG p.351, p.395

Has the CD been finalized?

- A CD-R/RW disc that you wrote using the Media mode Make Audio CD page cannot be played in the Media mode Play Audio CD page or in Sampling mode until you also finalize the disc. Execute the menu command **Finalize Audio CD** to finalize the disc. → PG p.416

### Noise, Distortion, and other audio problems

#### Noise and distortion occur in the input sound or the recorded sound

If you are recording from audio inputs 1 and/or 2, are the AUDIO INPUT LEVEL knob and **Recording Level** setting appropriate?

- If **Recording Level** indicates "ADC OVERLOAD !," adjust the LEVEL knob. If "CLIP !" is displayed, adjust the **Recording Level** slider. → p.211

If you are inputting to the S/P DIF IN jack, is the level of the output device and the **Recording Level** set appropriately?

- If "CLIP !" appears, adjust the **Recording Level** slider.

Is the system clock set correctly?

- If cyclic click noise is occurring, check that you have selected the **System Clock** that is being input. → PG p.359

#### Noise or oscillation is heard

When using an effect on the external audio source being input from AUDIO INPUT 1 and 2, oscillation may occur depending on the type of effect or on the parameter settings. Please adjust the input level, output level, and effect parameters. You need to be particularly careful when using a high-gain effect.

After a sample edit has been executed, or after a stereo sample has been recorded, a small noise may be heard. This has no effect on the audio data that was edited or sampled.

When using the MIDI/Tempo Sync function to control the delay time of an effect, noise may occur in the delay sound. This noise is due to discontinuities in the delay sound, and is not a malfunction.

Some effects, such as 017: Stereo Analog Record, generate noise intentionally. It is also possible to create oscillation using a filter with resonance. These are not malfunctions.

Note that if you use the following effects with the routing described below, a feedback loop will be created, possibly producing a loud noise. Please use caution.

If the signal from an oscillator or timbre/track output, or the signal after an insert effect, is sent to the FX Control bus and that signal is output directly, with this output sent to the FX Control bus, a loud noise may be output. (It is also possible that a DC component will be output at the maximum level, producing silence.)

- When using the 002: Stereo Limiter or 005: Stereo Gate, and the **Envelope Source** of these effects is set as either FX Control 1 or FX Control 2, and **Trigger Monitor** is On.
- When using 156: Vocoder, with the **Modulator Source** of this effect set to FX Control 1 or FX Control 2, and the **Modulator High Mix** set to other than 0.

If the EXB-RADIAS oscillator output is sent through an insert effect, and then sent to both the AUX bus and the FX Control bus, the effect settings described above will produce a feedback loop, possibly producing a loud noise. Please use caution. (It is also possible that a DC component will be output at the maximum level, producing silence.)

### Notes do not stop

In Prog P1: Basic/DT/Ctrls– Key Zone/Scale, select the Program Basic page, make sure that the **Hold** checkbox is unchecked. → p.138, PG p.27

Did you use Tone Adjust to turn **Hold** on? → PG p.22

In Global P2: Controller, make sure that **Damper Polarity** or **Foot Switch Polarity** is set correctly. → PG p.371

---

## Programs and Combinations

### Settings for oscillator 2 are not displayed

Make sure that the **Oscillator Mode** (Prog P1: Basic/DT/Ctrls) parameter is set to Double. → p.51

### Program does not sound

Have you loaded the multisample or sample that the program uses?

### RADIAS program does not sound

If the oscillator output of the optional EXB-RADIAS or the oscillator output after passing through an insert effect is sent via the AUX bus to the input of the EXB-RADIAS oscillator or the vocoder, a feedback loop will be created. If this occurs, the input signal will be automatically cut internally to prevent a loop from occurring. Be aware that in this case, there will be no sound.

### A combination does not play correctly after you load data

In the dialog box when you saved the data, did you check the items that you wanted to save? → p.143

Are the bank/numbers of the programs used by the combination the same as when the combination was created?

- If you have switched program banks, you can use the **Change all bank references** menu command to change the program bank for each timbre of a combination. → PG p.383

### Can't write a Program

You can't write EDS programs into bank INT-F. Likewise, RADIAS programs of the optional EXB-RADIAS cannot be written to banks INT-A–E.

With the factory settings, the bank type for USER-A–G banks are all set to EDS programs, so you won't be able to write RADIAS programs.

- The bank type for banks USER-A–G can be changed to store either RADIAS or EDS programs by using the Global mode menu command **Set Prog User-Bank Type**. You'll need to change this setting if you want to write RADIAS programs. → PG p.382  
Is the Memory Protect **Program** checkbox (Global P0) cleared? → p.130

---

## Songs

### Song does not play correctly after being loaded

In the dialog box when you saved the data, did you check all of the items that you wanted to save? → p.143

Are the programs used by the song the same as when the song was created?

- If you have switched program banks, you can use the menu command **Change all bank references** to change the program bank for each track of a song. → PG p.383
- When saving the song, it is best to use **Save All** or **Save PCG & SEQ** so that the programs are saved together with the song. Then when loading, load both the .PCG and the .SEQ data. → p.143

Have you loaded the multisamples and samples used by the program?

### Playback does not start when you press the SEQUENCER START/STOP switch in Sequencer mode

Is the **MIDI Clock** (Global P1: MIDI) set to Internal or Auto? → PG p.364

### Can't record in Sequencer mode

Did you use **Track Select** to select the MIDI track that you want to record? → p.85

Is the Memory Protect **Song** check box (Global P0) unchecked? → p.130

Is the **MIDI Clock** (Global P1: MIDI) set to Internal or Auto? → PG p.364

### RADIAS programs of the optional EXB-RADIAS don't sound correctly in a song

Is the optional EXB-RADIAS correctly installed in the M3?

Is the [R] symbol shown for the track to which the RADIAS program is assigned?

- Turn **Enable RADIAS** (Seq P2: EQ/Option) on (checked).



### A combination copied using “Copy From Combi” doesn’t record via KARMA as it did when you were playing it in Combination mode

- Is **Multi REC** (Seq P0: Play/REC) checked? → p.87
- Are the settings in the Copy from Combination dialog box correct? → p.89
- In the Copy from Combination dialog box, check the **Multi REC standby** option before you execute the copy. This will cause the settings to be adjusted automatically.

### Can’t record your performance using Tone Adjust

Changes you make using Tone Adjust are recorded as system exclusive data. Did you check the Global mode MIDI Filter **Enable Exclusive** check box? → PG p.368

### RPPR does not start

- Is the Seq P0: Play/REC **RPPR** setting checked? → p.97
- Are **Assign**, **Pattern Select**, and **Track** set correctly? → p.97
- If the **MIDI Clock** (Global P1: MIDI) parameter set to Internal or Auto? → PG p.364

### SMF you loaded in Media mode won’t play correctly

- Execute the menu command **GM Initialize** to initialize the settings. → PG p.273
- Set **Bank Map** to GM(2). → PG p.358

## Sampling

### Can’t sample

- Are the audio input settings correct?
  - For details, please see “Audio input and output – Audio inputs don’t work properly.” → p.209
- Is there free space in memory? → PG p.308, p.397
  - In order to sample to RAM memory, you must allocate sufficient space for sampling. → PG p.329, p.334
  - If you’re sampling to a USB storage device, select another USB storage device. → PG p.108, p.334
  - Delete unneeded samples. → PG p.329
  - Save important samples on external media, and then delete them from memory. → PG p.337
- If you’re sampling to external USB storage device, did you select recordable media?
  - Is the **Trigger** setting correct? → PG p.12, p.305
  - In Sampling mode if you are resampling with **Resample** set to Auto, has the sample to be resampled been assigned to the keyboard, and selected for **Key**? → p.115
  - Is the **Source Bus** setting correct?
    - If a “buffer overrun error occurred” message is displayed frequently when you are sampling to hard disk, execute the menu command **Check Medium**

(Media– Utility page) to find and correct any errors on the selected MS-DOS format media. → PG p.414

### A stereo sample can’t be played in stereo

- Is the multisample actually stereo?
  - Execute the menu command **MS Mono To Stereo** to convert the multisample to stereo. → PG p.333
- Is the sample name assigned correctly? → PG p.303

### Volume of a recorded sample is too low/too high

- Samples that you resampled at a **Recording Level** of approximately 0.0 (dB) have a lower volume than when you resampled them.
  - Did you turn on the **Auto +12 dB On** setting when you resampled? → PG p.275, p.307
  - If you resampled with **Auto +12 dB On** turned off, turn on **+12 dB** (Sampling mode Loop Edit page) for that sample. → PG p.315

### Song or CD playback stops temporarily when you sample

- Is “Auto Optimize RAM” checked?
  - If this is checked, RAM will be optimized automatically when sampling ends, meaning that the sound will stop when sampling ends. If a song is being played in Sequencer mode or if a CD is being played back, the playback will stop.

### When “Recording Level” is set to 0 dB, “CLIP !” does not appear even though the input sound is distorted

When the **Recording Level** setting is 0 dB, and the signal of an internal bus (L/R, AUX 1/2, AUX 3/4, Indiv. 1/2, Indiv. 3/4) is set to **Source Bus**, the “CLIP !” indication will not appear even if the input signal from the AUDIO INPUT 1, 2 jacks or the S/P DIF jack is at a level that causes distortion. This is due to the way in which the internal level is calculated.

If the **Source Bus** selection is Analog Input 1/2 or S/P DIF IN L/R, the signal will not be routed through the internal bus, and thus the level of the input signal will be sampled without change. If the input signal is distorted due to clipping, the “CLIP !” indication will appear if **Recording Level** is higher than 0 dB.

When the **Recording Level** is set to 0 dB and the sounds played by the M3 are clipping and distorting, and you are resampling these signals via an internal bus, the “CLIP !” indication will not appear in this case either, again due to the way in which internal levels are calculated.

## KARMA function

### KARMA does not start

- Is the KARMA ON/OFF switch turned on (lit)? → p.167
- If a KARMA module does not start in Combination or Sequencer mode, is the **Run Check Box** checked for

that module? Also, are the **Input Channel** and **Output Channel** settings appropriate? → p.171, p.176

Is **MIDI Clock** (Global P1: MIDI) set to Internal or Auto? → PG p.364

In the Global P0: Basic Setup page, is **All KARMA/DT Off** checked? → p.130

Is the KARMA LINKED LED lit?

- The KARMA function is linked with the drum track. Start the drum track to trigger KARMA. → p.179

---

## Drum Track function

### Drum Track does not start

Is the KARMA ON/OFF switch turned on (lit)? → p.185

You pressed the DRUM TRACK ON/OFF switch but the drum track pattern did not start.

- Is the DRUM TRACK [ON/OFF] switch blinking? **Trigger Mode** is set to Wait KBD Trig. The drum track pattern will start when you play the keyboard or receive a note-on. → p.185
- Did you select a pattern that does not contain data?

If the drum track pattern fails to start in Combination mode, is the **Output Channel** setting appropriate?

If the drum track pattern fails to start in Sequencer mode, are the **Input Channel** and **Output Channel** settings appropriate? → p.185, p.191

Is **MIDI Clock** (Global P1: MIDI) set to Internal or Auto? → PG p.364

In the Global P0: Basic Setup page, is **All KARMA/DT Off** checked? → p.130

When you switch the KARMA Master scene, the drum track pattern is no longer heard.

- Have you checked the **DT Run** (Drum Track Run) check box of the KARMA Master scene? → p.192

---

## X–Y control

### Can't control the volume

Is the **Enable Volume Control** check box checked? → PG p.32, p.139, p.216

Is the Combination or Sequencer mode **X–Y Assign** setting appropriate? → PG p.141, p.218

Have you checked the **Enable Program X–Y Volume** check box so that the volume control of a program can be reproduced in Combination or Sequencer mode? → PG p.141, p.218

### CC control does not work

Is the **Enable CC Control** check box checked? → PG p.33, p.143, p.220

Are the **X–Y X mode** and **Y mode** settings appropriate? → PG p.33, p.143, p.220

In Combination or Sequencer mode, are the **Enable Combi X–Y CC** or **Enable Seq X–Y CC** check boxes checked? → PG p.144, p.221

Have you checked the **Enable Program X–Y CC** check box so that the CC control of a program can be reproduced in Combination or Sequencer mode? → PG p.144, p.218

---

## Drum Kits

### The drumsample's pitch does not change

You have left the **Assign** check box unchecked, and want to play the drumsample at the adjacent right a semitone lower, but the pitch does not change.

- If you have selected a drum program in Program mode, and then want to edit the drum kit in Global mode, go to the Prog P2: OSC/Pitch– OSC1 Pitch page and set **Pitch Slope** to +1.0 before you enter Global mode. → PG p.40

---

## Effects

### Effects are not applied

Have you selected effect program 000?

- Select an effect other than 000: No Effect for “IFX1–5,” “MFX 1, 2” or “TFX.”

When CONTROL ASSIGN REALTIME CONTROL is on, have you used switches 1–8 to turn the effect off?

Are the Effect Global SW **IFX 1–5 Off**, **MFX1&2 Off**, or **TFX Off** (Global P0: Basic Setup page) settings checked? → PG p.357

If you are in Combination, and Sequencer mode, and master effects are not applied when you raise the **Send1** or **Send2** of the timbre/track, does **Return 1** or **Return 2** from the master effect need to be raised? → PG p.103, p.183, p.263

Alternatively, has **Send 1** or **Send 2** for each oscillator of the program used by the timbre/track been lowered? → PG p.178, p.257

*Note:* The actual send level is determined by multiplying the send setting of each oscillator in the program with the send setting of the timbre/track.

Have you routed the output to an insert effect? → PG p.10, p.30, p.98, p.100, p.129, p.177, p.178, p.181, p.202, p.204, p.257, p.259

---

## MIDI

### The M3 does not respond to incoming MIDI data

Are all MIDI cables or USB cables connected correctly? → p.30, p.33

Is the MIDI data being received on the channel on which it is being transmitted? → PG p.615

## The M3 does not respond correctly to incoming MIDI data

Are the Global P1: MIDI settings **MIDI Filter Enable**, **Program Change**, **Enable Bank Change**, **Enable Control Change**, **Enable AfterTouch**, and **Enable Exclusive** each checked? → PG p.367

Does the M3 support the types of messages that are being sent to it? → PG p.615

### Incorrect response to program change messages

Is the **Bank Map** setting correct? → PG p.358

---

## Pads or damper pedal do not respond correctly

### Pad response is wrong

Execute the menu command **Pad Calibration** (Global P0: Basic Setup) to correctly calibrate the pad sensitivity. → PG p.383

### Damper response is wrong

Execute the menu command **Half Damper Calibration** (Global P0: Basic Setup) to correctly calibrate the half-damper pedal sensitivity. → PG p.383

---

## USB Media, and CD

### The date of the data is wrong

The files you saved or WAVE files you sampled have the incorrect date.

- Use the menu command **Set Date/Time** (Media-Utility page) to specify the correct current date and time. → p.148

### External USB devices

#### The drive of a connected USB device is not detected

Has the media been formatted? → PG p.413

Is the external device connected correctly? → p.33

You may have turned on the power of the USB device after powering-on the M3.

- Execute the menu command **Scan USB device** (Media- Media Information) to re-mount the USB device. → PG p.419

#### “Error in writing to medium” occurs frequently when saving data to the external device

Execute the menu command **Check Medium** (Media-Utility page) to detect and repair errors on the media. → PG p.414

#### CD media in a USB CD-R/RW drive is not detected

Did you touch the display?

## CD-R/RW drive

### Can't write

If you are unable to save data such as PCG or SNG files, has the disc been formatted?

If you are writing WAVE file to create an audio CD, it is not necessary to format the disc.

Are you using the recommended media for your drive?

If you are writing from an external USB drive to CD-R/RW, it is possible that the transfer speed is insufficient.

- Writing may be successful if you lower the writing speed. → PG p.415

Are you using blank media?

- If using CD-R, please use new media. If using CD-RW, use the menu command **Erase CD-RW** (Media- Make Audio CD) to erase the contents of the media before you execute Save.

### An M3 USB CD-R/RW is not recognized by an external device

A CD-R/RW saved or copied on the M3 using packet writing is not recognized on a computer.

- If you install a UDF version 1.5 compatible UDF reader or packet writing software on your computer, it will be possible to recognize the disc. → PG p.634
- In the case of a CD-R, it may be possible to make the disc be recognized by executing the menu command **Convert to ISO9660 Format** (Media-Utility page) to convert the disc to ISO9660 format. However depending on the state in which the disc was saved, it may be converted into ISO9660 level 3 format, and may still not be recognized. In this case if you install ISO9660 level 3 compatible reader software or packet writing software on your computer, it will be possible to recognize the disc. → PG p.414

A CD-R/RW that was saved or copied on the M3 using packet writing is not recognized by the TRITON/TRITON pro/TRITON proX/TRITON-Rack/TRITON Le/TR.

- These models do not support UDF version 1.5, and therefore will not recognize such a disc.
- In the case of a CD-R, it may be possible to make the disc be recognized by executing the menu command **Convert to ISO9660 Format** (Media-Utility page) to convert the disc to ISO9660 format. However depending on the state in which the disc was saved, it may be converted into ISO9660 level 3 format, and may still not be recognized. → PG p.414

Your computer is unable to read a CD-R converted to ISO9660 format.

- If packet writing software is installed, it may not be possible to read this data. In this case, you should either temporarily disable this software, or uninstall it.

### Can't write audio tracks

Additional writing is not possible on a CD-R/RW disc that has been finalized.

### Can't play back the disc on an audio CD player

Did you finalize the disc?

- If you want to finalize the disc after writing additional data, check the **Execute finalize too** check box when executing the menu command **Write to CD** (Media- Make Audio CD), so that the disc will be finalized. → p.151, PG p.415
- If you only want to finalize the disc, select the menu command **Finalize Audio CD** (Media- Make Audio CD), and press the OK button to finalize the disc. → PG p.415

Are you using CD-R media?

- Since some CD players are unable to play CD-RW media, we recommend that you use CD-R media.

Have you tried using a different type of media?

- Some CD-R/RW media cannot be played by some CD players. You may be able to play back successfully by using a different type (brand) of CD-R/RW media.

---

## WAVE files

### Can't load

Is the WAVE file in a format that the M3 can load?  
→ PG p.405, p.629

- Only 48 kHz or 44.1 kHz WAVE files can be inserted into the Track CD List in the Media mode Make Audio CD page.

### Can't preview

Is the WAVE file in a format that the M3 can load?  
→ PG p.629

- You can't preview if the name of the WAVE file on external media is longer than eight characters. Rename the file so that its name is eight characters or fewer.

---

## Connections with a computer

### USB or FireWire (optional EXB-FW)

#### The M3 does not respond to MIDI data sent from outside

Are all USB cables and FireWire (IEEE 1394) cables connected correctly? → p.30, p.31

#### The computer does not detect the M3

Is the USB cables and the FireWire cable connected correctly? → p.30, p.31

It is possible that the operating system of your computer has become unstable. Power-off your

computer and the M3, and then turn the power back on again.

#### An error occurs when you disconnect from the computer

Never disconnect the M3 from the computer while your host application is in use.

#### While connected, you are asked to install software or a device driver

Does the operating system version of your computer support the M3? → p.34

---

## Included CD-ROM

### Can't install the driver

Is the USB cable connected correctly?

Is the CD-ROM inserted in your CD drive?

- Make sure that the CD-ROM is inserted correctly.

Is the lens of your CD drive dirty?

- Use a commercially-available lens cleaner to clean the lens.

Are you able to use USB?

- If you are using Windows XP, go to [Control Panel] → [System], and select the [Hardware] tab. In [Device Manager], check the settings for Universal Serial Bus Controller and USB Root Hub.

Has the M3 been detected as an unknown device?

- If you are using Windows XP, go to [Control Panel] → [System], select the [Hardware] tab, and check [Device Manager]. If the M3 has not been detected correctly, it will be displayed in "Other devices" or "Unknown devices." Reconnect the USB cable; if the M3 is again displayed as an "Unknown device," the computer has failed to detect it correctly. Delete the "Unknown device" entry, and reinstall the driver. → p.34

### Your software does not respond to the M3

Is the USB cable connected correctly?

Did you install the driver?

Has your computer detected the connected M3?

- If you are using Windows XP, go to Control Panel → "Sounds and Audio Devices Properties" and click the Hardware tab.

If you are using Mac OS X, go to Macintosh HD → Application folder → Utility folder → "Audio MIDI Settings," select the "MIDI Devices" tab, and check that the M3 has been detected.

- ⚠ Some computers may not recognize the M3 because of their hardware configuration.

Check the M3's assignments and USB-MIDI port settings.

The connected device or software may not support the messages you are transmitting. Refer to the manual of the connected device or software to verify that it responds to the messages you are transmitting.



## Error messages

### Error and confirmation messages

#### A (ADC–Are You Sure)

##### ADC Overload

**Meaning:** If the **ADC OVERLOAD!** indication appears above the Recording Level bar, the signal is distorting because of an overload at the AUDIO INPUT stage. To solve this problem:

- Adjust the MIC/LINE gain select switch, the LEVEL knob (AUDIO INPUT 1 and 2 only), or the output level of your external audio source.

##### Are you sure ?

**Meaning:** This message asks you to confirm execution. To execute press the OK button. To cancel, press the Cancel button.

#### B (Buffer)

##### Buffer overrun error occurred

**Meaning:** When sampling to external USB media, the processing could not keep up with the sampling. To solve this problem:

- Execute the Media Utility menu command **Check Medium**. Then try the sampling operation again. If this does not resolve the problem, copy several files from that media to other media, delete those files, and then try the sampling operation again.

*Note:* Sampling may not be possible because of the media you're using. Please use the recommended types of media. (See "Media that can be used with the M3" on page 223)

*Note:* If the "Buffer overrun error occurred" error message appears, the data up to the point the error occurred has been sampled, but the data at the point the error occurred may not play back correctly.

##### Buffer underrun error occurred

**Meaning:** When playing back a WAVE file from external USB media, the data could not be read fast enough for playback processing.

- Copy the file you want to play into another folder, and then execute the operation again.

*Note:* Playback may not be possible because of the media you're using. Please use the recommended types of media. (See "Media that can be used with the M3" on page 223)

#### C (Can't calibrate–Completed)

##### Can't calibrate

**Meaning:** Calibration could not be performed correctly.

- Try again.

##### Can't copy/swap double size effect

**Meaning:** When copying or swapping an insertion effect, you attempted to place a double-size effect in IFX5.

- Modify your settings so that a double-size effect is not moved to IFX5, and execute again.

##### Can't load divided PCG file

**Meaning:** The menu command **Load PCG (RAM) and Samples** cannot be performed on a divided PCG file.

##### Can't open pattern

**Continue?**

**Meaning:** When you finished recording, it was not possible to allocate enough memory to open the pattern that was Put into the track. (When it must be opened automatically.) If you press the OK button, the pattern data will be deleted, and the recorded or edited content will be saved. If you press the Cancel button, the recorded content will be discarded.

##### CLIP !

**Meaning:** The "CLIP !" indication will appear if the signal level exceeds 0 dB.

- The signal being sampled has overloaded; use the **Recording Level** slider to adjust the level.

*Note:* When inputting from the AUDIO INPUT 1, 2 jacks, you will obtain the widest possible dynamic range if you adjust the MIC/LINE gain select switch and the LEVEL knobs as high as possible without allowing "ADC OVERLOAD!" to appear. In addition, you should set **Level (0–2a)** to 127, and adjust **Recording Level** as high as possible without allowing **CLIP !** to appear.

##### Completed

**Meaning:** Execution of the command ended normally.

##### Completed. Please turn the power off, and then on again

**Meaning:** Execution of Update System Software has been completed successfully. Restart the system to complete the update. Turn the power switch off, and then on again.

#### D (Destination–Disk)

##### Destination and source are identical

**Meaning:** When copying or bouncing, the same song, track or pattern was selected for both the source and destination. To solve this problem:

- Select a different song, track, or pattern for the source and destination.

##### Destination from-measure within the limits of source

**Meaning:** When executing the Move Measure command for all tracks or within the same track, the specified destination measure is within the source range. To solve this problem:



- Set a destination measure that is outside of the source range.

#### Destination is empty

**Meaning:** When editing, the track or pattern that was specified as the destination contains no musical data. To solve this problem:

- Select a track or pattern that contains musical data.

#### Destination measure is empty

**Meaning:** The measure that was specified as the destination contains no data.

- Specify a destination measure that contains data.

#### Destination multisample already exists

**Meaning:** A multisample already exists at the destination (save location) multisample.

- Either delete the multisample at the destination (save location), or change the save destination multisample number.

#### Destination multisample and source multisample are identical

**Meaning:** The same multisample is selected for the source and destination.

- Select different multisamples for the source and destination.

#### Destination sample already exists

**Meaning:** A sample already exists at the destination (save location).

- Either delete the sample at the destination (save location), or change the save destination sample number.

**Meaning:** The save-destination sample number is temporarily being used to execute Time Stretch, and therefore the Save operation cannot be executed.

- Change the save-destination sample number.

#### Destination sample data used in source sample Can't overwrite

**Meaning:** Since the sample data at the destination (save location) is also used by the source sample, it cannot be overwritten.

- Without using Overwrite, specify a different sample for the destination (save location).

#### Destination sample is empty

**Meaning:** The sample for editing is empty.

#### Destination song is empty

**Meaning:** The song that was specified as the copy destination or bounce destination does not exist.

- Execute the Create New Song command in the dialog box that appears when a new song is selected before copying or bouncing.

#### Directory is not empty

#### Cleanup directory Are you sure?

**Meaning:** When deleting a directory, files or directories exist within that directory.

- Press the OK button to delete all files and/or directories within that directory.

#### Disc full

**Meaning:** When executing command in the Media mode Make Audio CD page, **Write to CD** there is insufficient space remaining on the USB CD-R/RW for the data to be written.

- Either write to other media, or remove unneeded tracks.

#### Disk not formatted

**Meaning:** When you attempted to perform a high-level format (quick format) of media, the media had not been physically formatted yet. To solve this problem:

- Execute the Media mode Utility menu command **Format** to physically format the media (full format).

## E (Error-Exceeded)

#### Error in formatting medium

**Meaning:** An error occurred while performing a physical format (full format) or high-level format (quick format) of the media. To solve this problem:

- Use other media.

**Meaning:** When executing the Media mode Utility menu command **Convert to ISO9660 Format**, an error occurred while rewriting the UDF area. To solve this problem:

- Use other media.

#### Error in reading from medium

**Meaning:** An error occurred while reading data from media. This error may also appear when data is being written to media by a Save or Copy operation. To solve this problem:

- Execute the reading operation once again. If the same error occurs, it is possible that the data on the media has been damaged.

#### Error in writing to medium

**Meaning:** A verification error occurred while writing data to a medium. To solve this problem:

- It is possible that the media has been physically damaged. Try another media. Avoid using the media that produced the error.
- When using external USB media, execute the Media mode Utility menu command **Check Medium**.

#### Exceeded 16 Programs - some data not loaded

**Meaning:** You exceeded 16 programs while performing Advanced Conversion Load. When an AKAI Program is loaded, it will be converted into multiple programs and one combination according to its structure. At this time, the maximum number of M3 programs resulting from this conversion is limited to 16, which is the maximum number of programs that can be used in a combination. To solve this problem:

- Load the AKAI programs individually, and edit them on the M3.
- Instead of using Advanced Conversion Load, load the multisamples or samples, and edit them on the M3.

**Meaning:** You exceeded sixteen programs while loading a SoundFont 2.0 file. According to the structure of the sound data in a SoundFont 2.0 file, the data being loaded will be converted into multiple programs and one combination. At this time, the maximum number of programs within the M3 following the conversion are limited to the sixteen programs that can be used by a combination. This sound will not play correctly.

## F (File–Front)

### File already exists

**Meaning:** When executing a **Create Directory** or **File Rename** operation, a directory or file of the same name already exists on the media.

**Meaning:** When executing the Media mode Utility **Copy** command without using wild cards, the copy destination contained a file of the same name as the copy source.

**Meaning:** When you executed the Media mode Utility **Save Sampling Data** for All, All Multisamples, All Samples, or One Multisample, a directory already existed on the media with the same name as the directory that you attempted to create on the M3.

**Meaning:** When sampling to the hard media, an identically-named file exists in the save-destination.

- Either delete the existing directory or file, or specify a different name.

### File contains unsupported data

**Meaning:** You attempted to load an AIFF, WAVE, or KSF file that was in a format not supported by the M3.

- In the case of a AIFF or WAVE file, use a computer (if possible) to convert the file into a format that is supported on the M3, and then load it.

### File is read-only protected

**Meaning:** You attempted to write to a file or to delete a file that had a read-only attribute.

**Meaning:** You attempted to save a file to media that contained a read-only file of the same name.

- Save the file with a different name.

**Meaning:** You attempted to save a file or directory in a Locked directory.

- Use the menu command **Lock/Unlock** to unlock the directory.

### File unavailable

**Meaning:** You attempted to load or open a file whose format was incorrect.

### File/path not found

**Meaning:** When loading a sample file in Media mode, the specified file does not exist. Alternatively, the specified filename does not exist in the location you selected in a dialog box for choosing another directory level or other media.

**Meaning:** When executing the **Delete** command in the Media mode Utility page, the specified file did not exist.

**Meaning:** When executing the **Copy** command in the Media mode Utility page, and you used a wild card to specify the copy file name, the specified file was not found. Alternatively, the length of the copy source path name exceeded 76 characters.

**Meaning:** In Media mode when you used the Open button to open a directory, the path length including the selected directory name exceeded 76 characters.

**Meaning:** When executing Insert in the Media mode Make Audio CD page, you attempted to use the Insert All button to add a WAVE file, but no WAVE file with a sampling frequency of 44.1 kHz or 48 kHz exists in the selected directory.

- Check the file or directory.

**Meaning:** In Media mode when loading a .KCD file, a WAVE file listed in the Audio Track List could not be found.

- The file whose Size is not shown in the Media mode Make Audio CD page is the one that could not be found. Check the file or directory, or delete it from the Audio Track List.

### Front sample data used in rear sample

#### Can't overwrite

**Meaning:** When executing **Link** in the Sampling mode Sample Edit page, the sample data of the front sample is also being used by the rear sample, and therefore cannot be overwritten. To solve this problem:

- Instead of using **Overwrite**, specify a different sample as the save-destination.

## I (Illegal–Index)

### Illegal file description

**Meaning:** The filename that you specified when saving a file or creating a directory contained invalid characters. To solve this problem:

- Change the filename you are specifying. Filenames not permitted by MS-DOS cannot be used as a filename.

### Illegal SMF data

**Meaning:** You attempted to load a file that was not a Standard MIDI File.

### Illegal SMF division

**Meaning:** You attempted to load a Standard MIDI File that was timecode-based.

### Illegal SMF format

**Meaning:** You attempted to load a Standard MIDI File of a format other than 0 or 1.

### Inconvertible file exists

**Meaning:** A file that cannot be used with ISO9660 format exists on the media. To solve this problem:

- Media that was formatted or written by a device other than the M3 may be impossible for the M3 to convert into ISO9660 format. To perform the conversion, use the packet writing software that was used to format or write the media.

### Index number over limit

**Meaning:** When sampling into RAM in Combination, Program, or Sequencer mode, there are too many indexes to be simultaneously converted into a multisample.

- Either convert the samples into a different program or multisample, or use Sampling mode to delete some of the indexes before you continue sampling.

## M (Master–Multisample)

### Master Track can't be recorded alone

**Meaning:** When realtime-recording a single track, you attempted to begin recording with the master track as the current track.

- Select a MIDI for recording, instead of the Master Track.

### Measure number over limit

**Meaning:** The attempted edit operation would cause the track length to exceed 999 measures.

- Delete unnecessary measures.

### Measure size over limit

**Meaning:** When loading a Standard MIDI File, the number of events in a measure exceeded the maximum (approximately 65,535 events).

**Meaning:** The attempted edit operation would cause the maximum number of events in a measure (approximately 65,535) to be exceeded.

To solve either of these problems:

- Use event editing etc. to delete unwanted data.

### Medium changed

**Meaning:** When executing the **Copy** command in the Media mode Utility page, the media was exchanged or ejected, and it was not possible to copy between separate media on the same drive.

### Medium unavailable

**Meaning:** You selected a medium that does not allow writing.

### Medium write protected

**Meaning:** The other writing-destination media is write-protected.

- Turn off write protect on the other media, and execute the command once again.

### Memory full

**Meaning:** In Sequencer mode when editing a song, track or pattern, the total data of all songs has used up all of the sequence data memory, and further editing is not possible. To solve this problem:

- Delete other song data etc. to increase the amount of free memory.

**Meaning:** While realtime recording in Sequencer mode, there is no more free memory to accommodate the recorded data, so recording has been forcibly halted. To solve this problem:

- Delete other song data etc. to increase the amount of free memory.

### Memory overflow

**Meaning:** While receiving exclusive data in Media mode **Save Exclusive**, all remaining internal memory was used up. To solve this problem:

- If you are receiving two or more sets of exclusive data, transmit them separately to the M3.

**Meaning:** In Media mode, you attempted to load more sample waveform data than there was free memory capacity. To solve this problem:

- In Sampling mode, execute Delete sample to create free space in the sample waveform data area, and re-load the data.

### Memory Protected

**Meaning:** The internal program, combination, song, drum kit, wave sequence, KARMA GE is protected.

**Meaning:** The song was protected when you executed Auto Song Setup.

- In Global mode, turn off write-protect, and execute the write or load operation once again.

### MIDI data receiving error

**Meaning:** While receiving MIDI System Exclusive data, the format of the received data was invalid, for example because the size of the data was incorrect.

### Multisample L and R are identical

**Meaning:** Since the destination (save location) L and R multisample numbers are the same, the editing operation could not be executed. To solve this problem:

- Select a different multisample number for the L and R of the destination (save location).

## N (No 48kHz Clock–Now switching system clock source)

**No 48kHz Clock is detected from S/P DIF clock master device.**

**The System Clock cannot be changed to S/P DIF.**

**Meaning:** If the EXB-RADIAS is installed, the Global mode P0: Basic Setup– System Preference **System Clock** cannot be switched to S/P DIF unless a 48 kHz system clock is being input.

- Please input a 48 kHz system clock from your S/P DIF Optical format compatible device into the M3's S/P DIF IN jack. Only 48 kHz is supported. After this is input, you'll be able to switch **System Clock** to S/P DIF.

### No data

**Meaning:** When loading a Standard MIDI File, the file contained no events.

**Meaning:** When you executed Samples in One Multisample in **Export Smpl as AIFF/WAVE** command in the Media mode Save page, there were no samples.

To solve either of these problems:

- Create sample data.

**No medium**

**Meaning:** When executing a command in Media mode, no media was inserted in the drive. To solve this problem:

- Insert media such as a mount the drive.

**No recording track specified**

**Meaning:** When performing realtime multi-track recording, you attempted to begin recording with no tracks set to REC. To solve this problem:

- Set the desired tracks for recording to REC.

**No space available on medium**

**Meaning:** When you attempted to save or copy a file, or to create a directory, there was not enough free space on the other medium. To solve this problem:

- Either delete an existing file, or exchange the medium with one that has sufficient free space.

**No space available on medium****Do you want to make a divided file?**

**Meaning:** When saving a .PCG or .KSF file, there was insufficient free space on the media. Please specify whether you want to save the file in divided form.

- Press the OK button to save the file across multiple volumes of media, or press the Cancel button to cancel.

**Not enough Drum Track pattern locations available**

**Meaning:** When converting a song's user pattern to a user drum track pattern, you have exceeded the number of user drum track patterns available for use.

- As necessary, execute the Media mode **Save PCG** command to save your user drum track patterns. In Sequencer mode, execute the menu command **Erase Drum Track Pattern** to increase the number of available drum track user patterns. Then try the conversion operation again.

**Not enough Drum Track pattern memory**

**Meaning:** When converting a song's user pattern to a user drum track pattern, there was not enough free memory.

- As necessary, execute the Media mode **Save PCG** command to save your user drum track patterns. In Sequencer mode, execute the menu command **Erase Drum Track Pattern** to erase other user drum track patterns and increase the amount of free memory. Then try the conversion operation again.

**Not enough memory**

**Meaning:** When starting realtime recording in Sequencer mode, the minimum amount of free memory (such as memory for the BAR events up to the recording start location) could not be allocated. To solve this problem:

- Delete other song data etc. to increase the amount of free memory.

**Meaning:** When in Media mode you attempted to load an EXL file from media other than the USB storage media, memory for temporary use could not be allocated on the USB storage media.

To solve either of these problems:

- On the USB storage media, create free space that is larger than the .EXL file.

**Not enough memory to load**

**Meaning:** When you attempted to load a .SNG file or a standard MIDI file in Media mode, there was insufficient free memory in the sequence memory. To solve this problem:

- Delete other song data etc. to increase the amount of free memory.

**Not enough memory to open pattern**

**Meaning:** There was insufficient sequencer memory to open the pattern, so editing is not possible.

- Either delete unwanted data such as a song, track, or pattern, or do not open the pattern.

**Not enough multisample memory**

**Meaning:** There is insufficient multisample memory. (The number of multisamples would exceed the maximum of 1,000.) To solve this problem:

- Delete multisamples to increase the amount of free memory.

**Not enough pattern locations available**

**Meaning:** When executing **Load Drum Track Pattern**, the attempted load operation would exceed the remaining number of user patterns in the selected song.

- Create a new song, and reload the data into the user patterns of that song. You can load up to 100 user patterns into each song. If you have more drum track patterns than this to load, you can divide them between two or more songs.

**Not enough relative parameter memory**

**Meaning:** There is insufficient memory for relative parameters. (The number of samples in the multisamples would exceed the maximum of 4,000.)

- Delete multisamples or indices of multisamples to increase the amount of free memory.

**Not enough sample memory**

**Meaning:** There is insufficient sample memory (for sample parameters or sample waveform data).

- Delete samples to increase the amount of free memory.

**Not enough sample/multisample locations available**

**Meaning:** The data you attempted to load would exceed the maximum number of multisamples or samples. To solve this problem:

- In Sampling mode, execute "Delete Multisample" or "Delete Sample" to free a sufficient number, and reload the data.



### Not enough song locations available

**Meaning:** When loading a .SNG file with “Append” specified, you attempted to load more songs than can be loaded.

- In Sequencer mode, execute “Delete Song” to increase the number of multi’s that can be used, and then load the song again.

### Not enough song memory

**Meaning:** When executing the Sampling mode “Time Slice” or “Save” commands, the total data for all songs occupies all of the sequence data memory area, so that saving is not possible.

**Meaning:** When sampling to RAM in Sequencer mode, it is not possible to create track data at the same time.

- Increase the amount of free memory, for example by deleting another song.

### Now switching system clock source... please wait!

**Meaning:** If the EXB-RADIAS is installed, this message will appear when you switch the Global mode P0: Basic Setup– System Preference **System Clock** setting to S/P DIF. Please wait until the switch is completed.

## O (Obey copyright rules–Oscillator)

### Obey Copyright Rules

**Meaning:** When you execute the Media mode Make Audio CD **Write to CD** menu command, or when you execute **Destination** in the Sampling mode Audio CD page **Destination** menu command.

Please read “COPYRIGHT WARNING” on page iii before you use this data.

### Oscillator Mode conflicts (Check PROG P1)

**Meaning:** In Sampling mode when you executed **Convert MS To Program** with Use Destination Program Parameters checked, the conversion destination program **Oscillator Mode** setting did not match.

- In Program mode, set the **Oscillator Mode** of the conversion destination program. If converting a monaural multisample, select Single. If converting a stereo multisample, select Double.

## P (Pattern–Program)

### Pattern conflicts with events

**Meaning:** It was not possible to execute the Bounce operation because one of the tracks contained a pattern, and the same measure of the other track contained events or a pattern.

- Open the pattern.

### Pattern exists across destination to-end-of-measure or source from-measure

**Meaning:** When moving a measure, the edit operation could not be executed because a pattern had been put in the destination end measure or the source start measure, and had not been opened.

- Open the pattern.

### Pattern exists in destination or source track

#### Open pattern?

**Meaning:** A pattern has been placed in the track that you specified as a destination or source for editing. If you wish to open the pattern and execute (the events of the pattern will be copied), press the OK button. If you wish to execute without opening the pattern, press the Cancel button.

### Pattern used in song

#### Continue ?

**Meaning:** When editing, the specified pattern has been placed in a track. If you wish to execute, press the OK button. If you decide not to execute, press the Cancel button.

### Program Type conflicts

**Meaning:** This message will appear when you execute Copy Tone Adjust if the copy-source and copy-destination program types are different. You can’t copy between EDS- and RADIAS-type programs.

## R (Rear sample–Root)

### Rear sample is empty

**Meaning:** When you executed **Link** in the Sampling mode Sample Edit page, the sample that you specified as the rear sample is empty.

- Specify a sample that contains data as the rear sample, and execute once again.

### Root directory is full

**Meaning:** You attempted to create a file or directory in the root directory of the media, but this would exceed the maximum number of root directory entries.

- Either delete an existing file or directory, or Open a directory to move down one level before executing once again.

## S (Sample–S/P DIF)

### Sample data used in other sample(s) Continue?

**Meaning:** Other sample(s) use the same sample data as the sample that you are editing. To continue editing, press the OK button.

### Sample L and R are identical

**Meaning:** The edit operation could not be executed because the destination (save location) L and R sample numbers are identical.

- Select different sample numbers for L and R of the destination (save location).

### Sample length is shorter than minimum

**Meaning:** You attempted to execute an editing operation that would make the sample data shorter than 8 samples.

- Change the editing range so that the sample data will be longer than 8 samples.

### Sample used in other multisample(s) Continue?

**Meaning:** The sample you are editing is used by other multisamples. To continue editing, press the OK button.



**Selected file/path is not correct**

**Meaning:** When loading a divided .PCG file, you attempted to load a .PCG file of the same name that was not divided or had differing contents.

- Load the correct .PCG file.

**Meaning:** When loading a KSF file that was split across multiple media, the order in which you attempted to load the files was incorrect.

- Load the KSF file in the correct order. To view the file number order in which the KSF files were saved, you can check the **Translation** menu command. (The sample name and number of the first KSF file will be displayed.)

**Slice point over limit****Can't divide**

**Meaning:** When using the Sampling mode **Time Slice** or **Time Stretch** commands, the Slice setting would divide the sample into more samples than the maximum possible number (1000), and thus **Divide** cannot be executed.

- Use **Link** to connect any **Index** that you do not require, and then execute **Divide**.

**Source file is not 44100Hz or 48000Hz****Can't convert**

**Meaning:** When executing the Media mode Utility menu command **Rate Convert**, you selected a WAVE file of a sampling rate other than 44.1 kHz, 48 kHz.

- You cannot convert WAVE files other than 44.1 kHz or 48 kHz.

**Source is empty**

**Meaning:** No data exists in the track or pattern that you specified as the source.

- Specify a track or pattern that contains musical data.

**Source sample is empty**

**Meaning:** When executing Insert, Mix, or Paste, the source sample is empty.

- Execute the Copy operation before executing Insert, Mix, or Paste.

**S/P DIF CLOCK ERROR!**

**Meaning:** The clock was not detected correctly when you set **System Clock** to S/P DIF or Word Clock in Global mode.

- Make sure that your external device is correctly transmitting a digital signal. The M3 can accept sampling frequencies of 48 kHz.
- Make sure that there is no problem with the optical cable.

**T (The clock–Track)**

**The clock battery voltage is low. Please do the following.**

1. **Turn off power, and replace the battery.**
2. **Turn on power.**

You will see this message one last time. This is normal.

3. **Set the date and time in Media mode.**

**4. Turn the power off, and then on again.**

**Meaning:** The battery for the clock/calendar function has run low. To solve this problem:

- Replace the battery as described in “Replacing the calendar battery” on page 207. After you install the battery, this message will appear once again when you turn on the power, but this is not a malfunction. Use the Media Utility menu command **Set Date/Time** to set the correct date and time.

**There is not readable data**

**Meaning:** Either the file size is 0 or the file does not contain data that can be accessed by the load or open operation. Alternatively, the data is damaged etc., and cannot be loaded or accessed.

**This file is already loaded**

**Meaning:** When loading a divided .PCG file, you attempted to load a file that had already been loaded.

- Load the .PCG files that have not yet been loaded.

**Track is full**

**Meaning:** In the Media mode Make Audio CD page, you attempted to insert a track that would make the total exceed 99 tracks.

- Cut unneeded tracks, and then execute the Insert operation once again.

**U (Unable to create directory–USB Hub)****Unable to create directory**

**Meaning:** You attempted to create a directory that would exceed the maximum path name length (76 characters for the full path name).

**Unable to save file**

**Meaning:** When executing the Media mode Utility menu command **Copy**, the copy destination path length exceeded 76 characters.

**Meaning:** When saving a file in Media mode, the save destination path exceeded 76 characters.

**Meaning:** When you executed the Media mode Utility menu command **Copy**, the file management data exceeded the size of the management area.

**Meaning:** When sampling to media, the save-destination path for the WAVE file exceeded 76 characters.

**USB HUB Power exceeded****Please disconnect USB device**

**Meaning:** The power consumption of your USB devices has exceeded the capacity of the hub to which they are connected. The USB hub will not be recognized correctly in this state. To solve this problem:

- If you're using a USB hub or device that is capable of being self-powered, use it in self-powered mode. If you are using more than one USB hub, you may be able to solve the problem by reconnecting a device to a different USB hub. After you've reconnected your device(s), execute “Scan USB Device.”

## W (Wave)

### WAVE file size over limit

**Meaning:** When using the Media mode Edit WAVE command, you exceeded the maximum sample length of 230,400,000 samples (80 minutes at the 48 kHz sample rate) that can be used for a WAVE file.

- Edit WAVE cannot edit a WAVE file that is longer than 230,400,000 samples (80 minutes at the 48 kHz sample rate).

## Y (You)

### You can't undo this operation      Are you sure?

**Meaning:** Once you enter event editing (even if you leave event editing without actually editing an event), it will no longer be possible to execute a Compare of the previous edit. If you wish to enter event editing, press the OK button. To cancel, press the Cancel button.

### You can't undo last operation      Are you sure?

**Meaning:** When you exit recording or event editing in Sequencer mode, the memory area for Undo (Compare function) is not allocated. If you wish to keep the data that was just recorded or edited, press the OK button. If you wish to return to the previous data (i.e., to delete the data that was just recorded or edited), press the Cancel button.

**Meaning:** When editing in Sequencer mode, memory area for Undo (Compare function) cannot be allocated. If you wish to execute the edit, press the OK button. (It will not be possible to return to the state before editing.) If you decide not to execute the edit, press the Cancel button.

- In order to allocate memory area for Undo (Compare function), delete unneeded data such as songs, tracks, or patterns. We recommend that you save data to media before you execute the edit operation.

# Media that can be used with the M3

## Types of media supported by the M3

(as of April 2007)

### External USB storage media

The M3 supports USB external storage class devices, including hard drives, flash drives, magneto-optical disks, floppy disks, etc. Both MS-DOS FAT16 and FAT32 formats are supported, with the following capacities:

FAT32: up to 2 Terabytes (2,000 Gigabytes)

FAT16: up to 4 Gigabytes

For more information, including requirements for external USB storage media and details on connecting USB devices, please see “Connecting a USB device (HDD, CD-R/RW, etc.)” on page 33.

### CD-R/RW (Internal and USB)

The M3 can read and write UDF format CD-R/RW disks. For more information, see “CD-R/RW disks on the M3” on page 634 of the Parameter Guide.

The M3 can also play and record audio CDs (CD-DA), and read ISO9660 (level 1) CDs.

## Operations that the M3 can perform on media

### Functions available with all media

- **Saving and Loading files (Media mode)**  
You can save and load any data stored in memory. For details on M3 file types, please see “Files, directories, and icons” on page 389 of the Parameter Guide. Loading or saving divided files is supported for USB media.
- **Utility operations (Media mode)**  
You can copy or format media.
- **Sampling/resampling (Program, Combination, Sequencer, Sampling modes)**  
If **Save to = MEDIA**, sampled/resampled Wave files will be written directly to media.
- **Wave file playback (Sequencer, Media modes)**  
Some limitations apply.\*2
- **Audio CD creation (Media mode)**  
You can create audio CDs from WAVE files, using either internal or USB CD-R/RW drives.
- **Convert to ISO9660 Format (Media mode)**  
The native M3 CD-R/RW format is UDF, which allows you to write repeatedly to the same CD. UDF is a standard format, but you can also convert such disks to the more common (but less flexible) ISO9660 format.

Function	USB: HD (Hard Disk)	USB: RM *1	USB: RM (Floppy Disk)	USB:CD-R/RW (Packet Write)	USB:CD-R/RW (ISO9660)
Save	●	●	●	●	×
Load	●	●	●	●	●
Sampling	●	● *2	×	×	-
WAVE File Play	●	●	×	×	×
Edit WAVE	●	●	×	×	×
Make AUDIO CD	● (from)	● (from)	×	● (to)	● (from)
Convert to ISO9660 Format	-	-	-	● (to)	-

● : supported

× : not supported

- : not applicable

\*1: Use USB 2.0 compatible devices for other than “save/load.”

\*2: Sampling/resampling to an MO larger than 640 MB is not possible.

CD-DA (audio CDs) can be ripped in Sampling mode.

*Note:* If you have any questions regarding the media that can be used, please contact your local Korg distributor. You may also check the Korg website (<http://www.korg.com>).

# Specifications and options

## Specifications

Operating temperature	±0 – +40 °C
-----------------------	-------------

### KYBD-61/73/88 keyboard assembly

System	KKS (KORG Komponent System)	
Keyboard	88	88 key Real Weighted Hammer Action (RH3) * The key weight of the RH3 keyboard differs in four stages across the pitch range (with low notes being heavier, and high notes being lighter), delivering a playing feel similar to that of a grand piano.
	73	Semi weighted
	61	Semi weighted
Controllers	Joystick, Ribbon Controller, SW1/SW2.	
Interface	TO MODULE (for connection with the M3-M sound module), TO MODULE (2nd) (73-key and 88-key only)	

### M3-M sound module

System	EDS (Enhanced Definition Synthesis)		
	MMT (Multi Modeling Technology) sound generator can be added by installing the optional EXB-RADIAS		
Sound Engine	Maximum Polyphony	120 voices max, single mode 60 voices max, double mode * The actual maximum polyphony will vary depending on oscillator settings such as stereo multisamples and velocity crossfading.	
	Preset PCM	256 Mbytes (when calculated as 16-bit linear data) 1,032 multisamples (including seven stereo), 1,606 drum samples (including 116 stereo)	
	PCM RAM	64 Mbyte is standard (512 bytes used by the system), expandable to 320 Mbytes by installing the EXB-M256 (option)	
	Programs (EDS)	Oscillator	OSC1 (Single), OSC1+2 (Double): Stereo multisamples are supported 4 velocity zones per oscillator, with switching, crossfades and layers.
		Filters	Four types of filter routing (single, serial, parallel, 24 dB) Two multi-mode filters per voice (low pass, high pass, band pass, band reject)
		Driver	Per-voice nonlinear driver and low boost.
		EQ	Three bands, with sweepable mid.
	Combinations	16 Timbres	Up to sixteen timbres, keyboard and velocity split/layer/crossfade, and modifications to the program setting via the Tone Adjust function
		Master Keyboard functionality	These allow you to control external MIDI devices
	Drum Kits	Stereo and mono drumsamples. 4-way velocity switches with crossfades and adjustable crossfade shapes (Linear, Power, Layer).	
	The number of ... -Combinations -Programs -Drum Kits	User Combinations	1,792 Combinations/384 Preload
		User Programs	1,664 Programs/640 (EDS: 512 + RADIAS: 128) Preload
		User Drum Kits	144 Drum Kits/32 Preload
		Preset Programs	256 GM2 Programs + 9 GM2 Drum Programs

Sampling	Open Sampling System	
	16bit/48kHz: Stereo/Mono Sampling	
	Sampling time (RAM)	RAM1: 64 Mbytes (installed as standard) allows up to approximately 11 minutes 39 seconds of mono sampling or approximately 5 minutes 49 seconds of stereo sampling. 512 bytes are used by the system.
		RAM2: 256 Mbytes (when the EXB-M256 is installed) allows up to approximately 46 minutes 36 seconds of mono sampling or approximately 23 minutes 18 seconds of stereo sampling.
		RAM1+RAM2: Total 320 Mbytes, allowing up to approximately 58 minutes 15 seconds of mono sampling or approximately 29 minutes 7 seconds of stereo sampling. (Continuous sampling across RAM1 and RAM2 is not possible.)
	Sampling time (MEDIA)	Maximum sampling time to a USB storage device is a maximum of approximately 80 minutes for one sample file, for either mono or stereo. This occupies approximately 440 Mbytes for mono, or 879 Mbytes for stereo.
	Number of samples/multisamples	4,000 Samples/1,000 Multisamples (Max. 128 indexes per Multisample.)
	Sample directly from audio CDs (CD-DA)	
	Load AIFF, WAVE, AKAI (S1000/S3000), SoundFont 2.0, KORG Format sample data	
	Time Stretch, Time Slice, Crossfade Loop, and other standard editing features.	
Effects	5 Insert Effects	In-line processing; stereo in - stereo out.
	2 Master Effects	Two effects sends; stereo in - stereo out.
	1 Total Effect	For overall processing on the main outputs, such as compression, limiting, and EQ; stereo in - stereo out.
	3-band Track EQ	High, low, and sweepable mid band. Per Program in Program Mode, per Timbre in Combination mode (16 total), and per Track in Sequencer mode (16 total).
	Effects types	170 types (Usable for insert, master, or total effects. However, double-size effects cannot be used as the total effect.)
	Modulation	Dynamic Modulation, two common LFOs
	Effects Control Bus	Stereo side-chaining for limiter, gates, vocoders, etc.
	Effects Presets	Up to 32 per Effect
	AUX bus	Two internal buses for sampling and routing audio to the EXB-RADIAS
X-Y control	X-Y MODE	TouchView display can be used as an X-Y controller. Hold function provided.
	X-Y MOTION function	X-Y Control finger movements can be recorded in realtime, and memorized for each program, combination, or song.
	Program mode	Oscillator volume, synth parameters, and effect parameters can be controlled.
	Combination, Sequencer modes	Timbre/track volume, synth parameters, and effect parameters can be controlled.
KARMA	KARMA Modules	1 Module in Program Mode; 4 Modules in Combination and Sequencer Modes, plus Master control module
	GE	2,093 Presets
	Controllers	ON/OFF, LATCH, MODULE CONTROL, KARMA SLIDERS 1-8, KARMA SWITCHES 1-8, KARMA SCENES 1/5-4/8 (8 scenes)
	KARMA Wave Sequence Control (change Multisamples via the KARMA engine), Free Randomize function, Time Signature Control, Auto RTC (Real Time Control) setup.	
Drum Track	Preset patterns	522 patterns (Held in common with synthesizer preset patterns.)
	User patterns	1,000 patterns. Patterns created in Sequencer mode can be converted to drum track user patterns.
	Trigger Mode / Sync / Zone settings can be specified	
Sequencer	16MIDI Tracks & 1 Master Track	
	128 Songs	
	Resolution: 480 ppq (parts per quarter-note)	
	Tempo: 40.00-300.00 bpm (1/100 bpm resolution)	
	Up to 210,000 MIDI events	
	16 preset/16 user template songs	
	Cue List function	20 cue lists. Songs can be arranged consecutively or repeatedly in up to 99 steps. A cue list can be converted back into a song.
	Patterns/RPPR	522 Presets /100 User Patterns (per Song) RPPR (Realtime Pattern Play/Recording): 1 set per Song.
	Format	Korg (M3) format, SMF (formats 0 and 1) supported
	In-Track Sampling function, Auto Song Setup function	



Media		Load, Save, Utility, Make Audio CD, Play Audio CD			
		Data Filer functionality (Save and Load MIDI System Exclusive Data)			
		CD-ROM/R/RW (UDF Format read/write), Record & Play audio CDs (CD-DA), ISO9660 Level 1			
		WAVE file editing functionality			
		CD-ROM/R/RW can be used if a commercially-available USB drive is connected.			
Controllers		Pads 1–8	Velocity-sensitive drum pads and chord triggers. PAD MODE switch - selects velocity-sensitive or fixed-velocity operation, CHORD ASSIGN switch		
		Control Surface	CONTROL ASSIGN Switches	MIXER (T1–8, T9–16, INPUTS), REALTIME CONTROL, EXTERNAL, TONE ADJUST, KARMA	
			RESET CONTROL Switch		
			8 Switches	MIXER: PLAY/MUTE (SOLO)	
				REALTIME CONTROL: IFX1–5, MFX1, MFX2, TFX on/off	
				EXTERNAL: External mode. External MIDI control.	
		TONE ADJUST: Control the Tone Adjust functions			
		8 Sliders	KARMA: KARMA control		
			MIXER: Volume		
			REALTIME CONTROL: Realtime modulation		
EXTERNAL: External mode. External MIDI control.					
TONE ADJUST: Control the Tone Adjust functions					
		* In External mode, the eight sliders, eight switches, and eight pads can be used as MIDI controllers. 128 setups can be stored. (102 are preloaded. These allow you to control software synthesizers or DAW software.)			
Drum Track		Switches = ON/OFF			
KARMA		Switches = ON/OFF, LATCH, MODULE CONTROL (Master/A/B/C/D), SCENES 1/5–4/8			
X–Y control		Switches = X–Y MODE, HOLD, MOTION			
User Interface		Display	5.7 inch Touch View Color Graphical Interface Color 320 x 240 pixel display, X–Y control function		
		MODE	Switches = COMBI, PROG SEQ, SAMPLING, GLOBAL, MEDIA		
		Value Controllers	Switches = $\Delta$ / $\nabla$ , 10-key numeric keypad, -, (, ENTER, COMPARE, VALUE Slider, VALUE Dial		
		BANK	Switches = I-A...G, U-A...G		
		SEQUENCER	Switches = PAUSE, REW, FF, LOCATE, REC/WRITE, START/STOP		
		SAMPLING	Switches = REC, START/STOP		
		TEMPO	Switches = TAP TEMPO, TEMPO Knob		
		Other	Switches = PAGE SELECT, EXIT, VOLUME MAIN Slider, display contrast		
Common specifications		Frequency response	20 Hz–20 kHz $\pm$ 1.0 dB	10 k $\Omega$ load	
		THD+N	20 Hz–20 kHz 0.08 %	10 k $\Omega$ load (typical)	
Audio Outputs		Analog	AUDIO OUTPUT (MAIN) L/MONO, R AUDIO OUTPUT (INDIVIDUAL) 1, 2, 3, 4	1/4" TS (Mono), unbalanced, Master Volume slider controls only L/Mono and R	
				Output Impedance	1.1k $\Omega$ stereo; 550 $\Omega$ mono (L/Mono only)
				Nominal Level	+4.0 dBu
				Maximum Level	+16.0 dBu
				Load Impedance	10 k $\Omega$ or greater
				Signal to noise ratio	90 dBu (typical)
				Dynamic range	91 dBu (typical)
		Headphone output	1/4" TRS (Stereo), Master Volume slider (link with Main output L/Mono)		
			Output Impedance	33 $\Omega$	
			Maximum Level	32+ 32 mW @33 $\Omega$	
			Digital	Optical S/P DIF	Format: 24 bit, S/P DIF IEC60958 EIAJCP-1201
					Sample Rate: 48 kHz
Digital output of the same signals as AUDIO OUTPUT (MAIN) L/Mono, R					
(Option) EXB-FW	6 channels, 24-bit, 48 kHz Sample rate	Digitally output the same signals as AUDIO OUTPUT (MAIN) L/Mono, R and AUDIO OUTPUT (INDIVIDUAL) 1–4			

Audio Inputs	Analog	Audio inputs 1, 2	1/4" TS (Mono), unbalanced	
			MIC/LINE input level switch, LEVEL knob	
			Input Impedance	10 k $\Omega$
			Headroom	12 dB
			Input level range LINE	-29 dBu ... +4 dBu or greater (typical)
			Input level range MIC	-54 dBu ... -17 dBu or greater (typical)
	Source Impedance	600 $\Omega$		
	Digital	Optical S/P DIF	Format: 24 bit, S/P DIF IEC60958 EIAJCP-1201	
(Option) EXB-FW		Sample Rate: 48 kHz 2 channels, 24-bit, 48 kHz Sample rate		
Control Inputs		DAMPER (Supports piano-style half-damper pedals as well as standard foot switches)		
		ASSIGNABLE SWITCH, ASSIGNABLE PEDAL		
		TO KYBD (for connection to keyboard assembly)		
MIDI		IN, OUT, THRU		
USB		2 USB 2.0 High-Speed ports (supports 480 Mbps) (TYPE A) with Mass Storage Device support, for connecting external hard drives, flash memory, etc.		
		1 USB (TYPE B), MIDI interface		
(Option) EXB-FW		KORG FireWire Audio/MIDI interface, 2 FireWire connectors		
		MIDI 1-in/1-out, Audio 2-in/6-out		
		Virtualized Hardware		
Power		AC Power Supply terminal, POWER On/Off switch		
Dimensions (mm) (W x D x H)		M3-M:	673 x 202 x 82	
		M3-M + KYBD61	1,016 x 372 x 121 (with M3-M folded down), 1,016 x 372 x 171 (with M3-M tilted up)	
		M3-M + KYBD73	-	
		M3-M + KYBD88	-	
Weight		M3-M	4.8 kg	
		M3-M + KYBD61:	14.1 kg	
		M3-M + KYBD73	-	
		M3-M + KYBD88	-	
Power Consumption		M3-M	35W	
		M3-M + KYBD61		
		M3-M + KYBD73		
		M3-M + KYBD88		
Accessories		Bracket (M3-M only), AC cable, Owner's Manuals (M3 Operation Guide) CD-ROM (M3 Parameter Guide (PDF), Voice Name List (PDF), KORG MIDI driver, M3 Editor/Plug-In Editor etc.)		

## Options

EXB-RADIAS	RADIAS Synthesizer Board
EXB-FW	FireWire Board
EXB-M256	256 MB Sample Memory Expansion Board
EX-USB-PCM series	PCM expansion USB memory
XVP-10	Expression/Volume Pedal
EXP-2	Foot Controller
DS-1H	Damper Pedal
PS-1	Pedal Switch

\* Appearance and specifications of this product are subject to change without notice. (April/'07)

## M3 MIDI Implementation Chart

Function		Transmitted	Recognized	Remarks
Basic Channel	Default	1 – 16	1 – 16	Memorized
	Changed	1 – 16	1 – 16	
Mode	Memorized		3	
	Messages	×	×	
	Altered	*****		
Note Number:	True Voice	0 – 127 *****	0 – 127 0 – 127	All note numbers 0–127 can be transmitted by the KARMA function or as sequence data
Velocity	Note On Note Off	○ 9n, V=1 – 127 ×	○ 9n, V=1 – 127 ×	
Aftertouch	Polyphonic (Key)	○	○	Polyphonic aftertouch transmitted only as sequence data *A
	Monophonic (Channel)	○	○	
Pitch Bend		○	○	*C
Control Change	0, 32	○	○	Bank Select (MSB, LSB) *P
	1, 2, 16, 18	○	○	Joystick (+Y, -Y), Ribbon, Value Slider *C
	4, 5, 7, 8, 10	○	○	Pedal, Portamento Time, Volume, IFX pan, Pan *C
	11, 12, 13	○	○	Expression, Effect Control 1, 2 *C
	64, 65, 66, 67	○	○	Damper, Portamento Sw., Sostenuto, Soft *C
	70 – 79	○	○	Sound (Realtime Sliders 1–4: 74, 71, 79, 72) *C
	80, 81, 82, 83	○	○	Switch 1, 2, Foot Switch, Controller *C
	93, 91, 92, 94, 95	○	○	Send 1, 2, Effect ON/OFF (IFxs, MFXs, TFX) *C
	14, 22 – 31, 102 – 109	○	○	KARMA Controllers *C, *2
	110 – 117, 118, 119	○	○	Pad1–8, X–Y Mode (X, Y) *C, *2
	6, 38, 96, 97	×	○	Data Entry, Increment, Decrement *C
	98, 99, 100, 101	×	○	NRPN (LSB, MSB), RPN (LSB, MSB) *C, *3
	0 – 119	○	○	Realtime Sliders 5–8, XY Assign *C
	0 – 119	○	○	Seq. Data, KARMA GE data output *C (Seq when received)
0 – 119	○	○	External Mode (SWs, Sliders, Pads) *C, *4	
120, 121	×	○	All Sound Off, Reset All Controllers *C	
Program Change	Variable Range	○ 0 – 127 *****	○ 0 – 127 0 – 127	*P
System Exclusive		○	○	*E, *5
System Common	Song Position	○	○	*1
	Song Select	0 – 127	0 – 127	*1
	Tune	×	×	
System Real Time	Clock	○	○	*1
	Command	○	○	*1
Aux Messages	Local On/Off	×	○	
	All Notes Off	×	○ 123 – 127	
	Active Sense	○	○	
	Reset	×	×	
Notes *P, *A, *C, *E: Transmitted/received when Global P1: MIDI Filter (Program Change, Aftertouch, Control Change, Exclusive) is Enable, respectively. *1: When Global P1: MIDI Clock is Internal, transmitted but not received. The opposite for External MIDI/USB/FireWire. *2: Valid if assigned as a MIDI control change in Global P2: Controllers. The number shown here is the CC default assignment. *3: RPN (LSB,MSB)=00,00: Pitch bend range, 01,00: Fine tune, 02,00: Coarse tune *4: Valid if assigned as a MIDI control change in Global P1: External 1, 2 *5: In addition to Korg exclusive messages, Inquiry, GM System On, Master Volume, Master Balance, Master Fine Tune, and Master Coarse Tune are supported.				

Mode 1: OMNI ON, POLY

Mode 2: OMNI ON, MONO

○ : Yes

Mode 3: OMNI OFF, POLY

Mode 4: OMNI OFF, MONO

× : No

Consult your local Korg distributor for more information on MIDI IMPLEMENTATION.

### **IMPORTANT NOTICE TO CONSUMERS**

This product has been manufactured according to strict specifications and voltage requirements that are applicable in the country in which it is intended that this product should be used. If you have purchased this product via the internet, through mail order, and/or via a telephone sale, you must verify that this product is intended to be used in the country in which you reside.

**WARNING:** Use of this product in any country other than that for which it is intended could be dangerous and could invalidate the manufacturer's or distributor's warranty.

Please also retain your receipt as proof of purchase otherwise your product may be disqualified from the manufacturer's or distributor's warranty.