

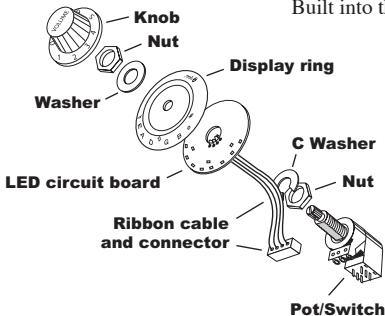

Advanced Tuning Technology  
Built into the guitar!



### PACKAGE CONTENTS

- 2 Display discs (Gibson® model only)
- 4 Display discs (Fender® model only)
- 1 LED circuit board
- 1 Volume pot/switch
- 1 9V battery
- 1 Battery holder and Velcro®
- 1 Pickup screw (Fender model only, see page 7)
- 2 Nuts
- 1 Plain washer
- 1 'C' washer
- 1 This manual

# Safety Instructions

1. Read Instructions.
2. Keep these Instructions.
3. Heed all Warnings.
4. Follow all Instructions.
5. Do not use this apparatus near water.
6. Clean only with a dry cloth.
7. Do not install near any heat sources such as radiators, heat registers, stoves, or other apparatus (including amplifiers) that produce heat.
8. Refer all servicing to qualified service personnel. Servicing is required when the apparatus has been damaged in any way, such as a damaged connector, liquid has been spilled or objects have fallen into the apparatus, the apparatus has been exposed to rain or moisture, does not operate normally, or has been dropped.
9. Object and Liquid Entry — Care should be taken so that objects do not fall into and liquids are not spilled into the inside of the apparatus.
10. Dispose of used batteries in accordance with all applicable laws and procedures.





Advanced Tuning Technology  
Built into the guitar!

---

# Contents

Safety Instructions .....	2
Introduction .....	4
Features .....	5
Installing the tuner .....	7
Tuner details .....	18
Tuning procedure .....	19
Changing the battery .....	21
Specifications .....	22
Warranty and repair .....	23

## Quick start!

See page 19 if the tuner is already installed and you can't wait a second longer to tune your guitar.

# Introduction

The *N-Tune*™ Chromatic tuner replaces the volume control of your electric guitar. It can be installed by experienced guitar technicians in most electric guitar or basses, without the need for routing, woodworking, or other modification.

The tuner will take the place of a standard three-terminal guitar potentiometer. Two pots are available:

- A 250kΩ pot intended for Strat®-style guitars.
- A 500kΩ pot intended for everything else.

**Note:** If the existing volume pot has extra features that make it do more than just control the volume, then these extra features will not work when the tuner is installed.

**IMPORTANT NOTE:** Installation of the *N-Tune* system may void the manufacturer's warranty on your guitar. Check with your guitar's manufacturer or the dealer from where the guitar was purchased for details. It is highly recommended that only a qualified guitar technician install the *N-Tune*. Zero Crossing Inc. assumes no liability for any damage or injuries incurred in relation to the installation or modification of your guitar.

# Features

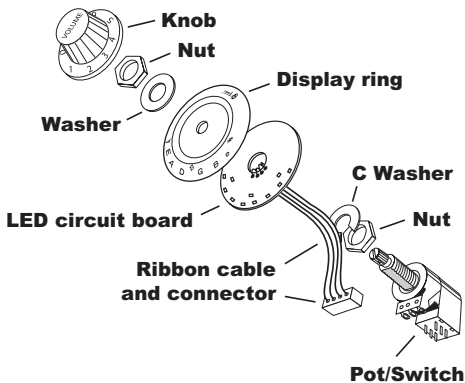

1. Your original volume knob is reused.
2. A display ring under the volume knob shows the various notes and the tuning-status symbols: flat, sharp, and tuned.
3. As a string is plucked, the signals from the pickups are sampled, and the note and tuning status are shown by the display's LEDs.

4. The potentiometer is a high grade design that will improve the performance of most guitars.
5. Pull the volume knob up to turn the tuner on. Press it down to turn it off.
6. The guitar's output is muted when the tuner is turned on (so the guitar's output is muted while you are tuning).
7. The tuner is powered by a user-replacable 9V battery.

# Installing the tuner

It is recommended that the following installation procedure should only be undertaken by experienced guitar technicians. Make sure that the tuner is the correct model for your guitar.

**IMPORTANT NOTE FOR FENDER GUITARS:**  
There are many different styles of electric guitars, and installing the *N-Tune* may require some compromises to consider for your particular Fender model. For instance, on some Fender Stratocaster models, you may notice that the *N-Tune* display ring can interfere with access to a portion of the pickup adjustment screw that is adjacent to the volume control. Accessing this screw for pickup height adjustment may require temporary removal of the *N-Tune* display ring and circuit board. Also, be aware that Fender uses different types of screws for this location on different Strat models. We have provided a replacement flat head/countersunk pickup adjustment screw that will work for some models. This provided screw requires a countersunk hole in the pick guard in order to allow for a flat surface under the edge of the *N-Tune* circuit board and display ring. Some other Stratocaster models do not have countersunk holes for the pick guard mounting screw.



It may be necessary to countersink that hole and use the provided screw to get your *N-Tune* to install flush to the pick guard. BE AWARE THAT INSTALLING THE COUNTERSUNK SCREW INTO A PICK GUARD THAT DOES NOT HAVE COUNTERSUNK HOLES CAN CAUSE DAMAGE TO THE PICK GUARD. FOR BEST RESULTS, REFER ALL INSTALLATIONS TO A QUALIFIED GUITAR TECHNICIAN WHO WILL GIVE YOU THE BEST OPTIONS FOR INSTALLATION OF THE *N-TUNE* IN YOUR GUITAR.

## Tools required

Soldering iron, solder, solder sucker or solder wick, pliers, a screwdriver selection, and nut drivers.

## Electro-Static Discharge (ESD) precautions

Take care to observe ESD precautions when handling the PCB board, to prevent damage to the circuit components from static electricity discharging from your body. Use an ESD wriststrap and correctly ground it to reduce the static electricity buildup on your body. Do not touch the LED circuit board's components or conductors, and do not get the LED circuit board out until the moment you are ready to use it.

# The Potentiometer

The potentiometer comes pre-wired to a 9V battery connector, with two short wires soldered, and a 4-pin connector.

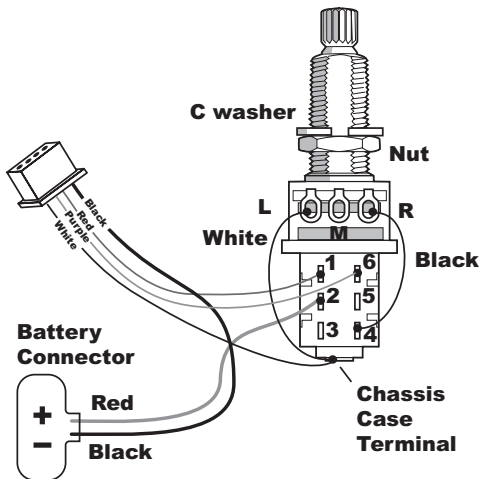

## Procedure

The following procedure assumes your guitar has a standard 3-terminal potentiometer. Use these instructions as a guide, but please refer to our website [www.n-tune.com](http://www.n-tune.com) for more details before proceeding.

1. Some guitar technicians may want to remove the strings on Strat® style guitars to allow for easier access to the pickguard. String removal is not required on most Gibson® style guitars.
2. For Strat-style guitars, remove the pickguard and safely store the mounting screws and any related hardware for easy retrieval. For Gibson style guitars, remove the backplate and safely store the mounting screws and any related hardware for access to the volume pot.
3. Before you remove the old volume pot, make a detailed sketch carefully noting the location of all of the wires that are connected.
4. The threaded shaft of the new pot is 8 mm in diameter. If the hole in the guitar is too small for the pot, a non-supported method would be to enlarge the hole to 11/32".

5. With the special C washer in place, adjust the nut until there is at least 5.5 mm of thread showing above the guitar's face. Check the pot does not interfere with the back plate or pick guard. (For reference, 5.5 mm is the thickness of the supplied plastic disc plus the thickness of a nut.

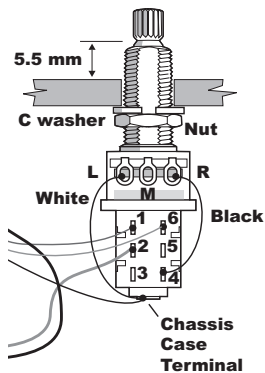

6. Solder the ground connections (typically the black wires) of the old pot to the L terminal or the chassis case terminal on the new pot.

**FOR FENDER®:** Solder the ground connections from the old pot to terminal L (or the chassis case) on the new pot (ground wires on Strat® and Tele® style guitars are typically black). Solder the input signal wire from the old pot (typically, the lead from the pickup selector switch) to terminal 5 on the new push/pull switch.

FOR GIBSON®: Traditional Gibson-style humbuckers have a single braided-shield pickup lead. For this type of pickup lead, the external braided shield is actually the ground conductor, and the hot lead is the insulated (coaxial) center conductor. To wire this type of pickup to the *N-Tune*, the center conductor (which was probably on “R” on the old pot) goes to terminal 5, and wire a jumper from terminal L to connect to the braided shield ground. It may be a good idea to wrap the end of the braided shield with some electrical tape, so that it does not touch any of the other terminals on the new pot and push/pull switch, grounding them out inadvertently.

7. Solder the output jack wire of the old pot (typically terminal **M**) to the **M** terminal on the new pot. (See the figure on page 12.)
8. Solder the input signal wire of the old pot (most likely terminal **R**) to terminal **5** on the new pot. (Note that it goes to terminal **5** and not terminal **R**.)
9. Solder any tone wires from the old pot to the same terminal on the new pot.

10. Before reassembling the guitar, plug it into an amp and check that the volume control is working. If all is well, unplug the guitar from the amp. If you have removed the strings, tap on the pickup with a screwdriver and you should hear the tapping through the amp.
11. Pass the connector of the LED circuit board through the open hole.
12. Push the pot into the hole and make sure the ribbon cable of the LED circuit board fits into the open slot in the C washer. Join together the connectors from the LED circuit board and the pot.

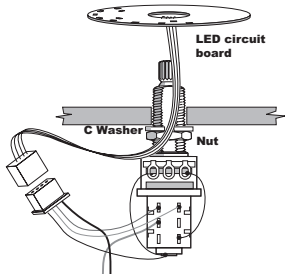

13. Install a new 9V battery, noting the correct “+” and “-” polarity. Fit it to the battery holder clip.

- Securely attach the battery holder clip to the inside cavity of the guitar with the provided Velcro. Find a place that will not be in the way of any pots, wires or other controls.
- Pull up the shaft of the new pot to turn on the tuner. Verify that the LEDs all light up. Push it in to turn it off.
- Carefully put the LED circuit board inside your chosen plastic display ring, ensuring that the LEDs line up with the pockets in the ring. Position the display ring/LED circuit board assembly in place over the threaded shaft of the pot, and gently pull the ribbon cable through the opening of the C washer.

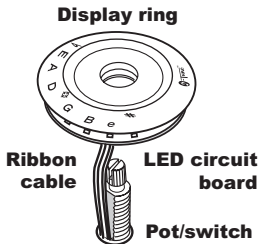

17. Place a plain washer and nut on top of the display ring, and hand tighten the nut so everything is loosely held in place.
18. Rotate the display ring/pcb/pot assembly until the “tuned” indicator is pointing up and clearly visible when you play the guitar.

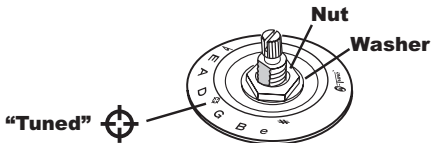

19. Make sure that the ribbon cable from the LED circuit board is seated correctly in the opening of the C washer, and not liable to be pinched. Using a nut driver, gently yet firmly tighten the top nut to lock everything in place.
20. Reassemble the guitar, being particularly careful to route all wires so they will not be pinched when the pickguard or other hardware is remounted. Be aware of any bulges or areas where things don't fit correctly, and correct these issues before proceeding. Restring the guitar if you removed the strings.

21. Push your original volume knob onto the knurl of the new pot.

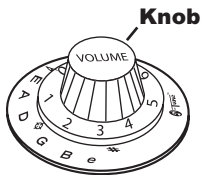





22. When the knob is pulled up, the tuner will work, and there should be no output to your guitar amp. See the next page for details of how to tune the guitar.

When the knob is down, the tuner and its LEDs will be off, and the guitar output will be restored.

You are now ready to tune up your guitar with *N-Tune!*

# Tuner details

The display ring is marked with notes A, B, C, D, E, F, and G. In addition there are tuning status indicators as shown in this table:

Mark	Description
	FLAT. The string needs to be tightened. This red light will flash faster as you get closer to tune.
	SHARP. The string needs to be loosened. This red light will flash faster as you get closer to tune.
	TUNED. The string is in tune when this green light comes on.
	TUNED-SHARP. This lights when the string is tuned to a sharp, such as F#.

The tuner allows you to easily tune any string to any note, and set up special tunings.

# Tuning procedure

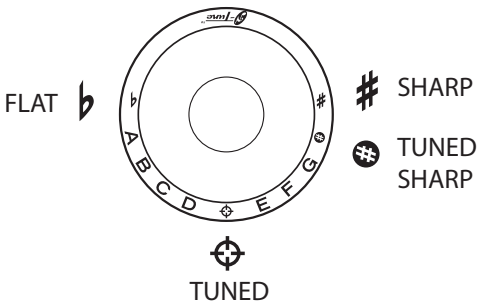

1. Pull on the volume knob to turn on the tuner. (When the tuner is on, the output is muted.)
2. Pluck a string, and its closest note will be displayed by the A, B, C, D, E, F, and G LEDs.
3. Tune the string until the desired note is displayed.
4. If the flat symbol is flashing red, then tighten the string. It will flash faster as you get closer to tune.

5. If the sharp symbol is flashing then loosen the string. It will flash faster as you get closer to tune. Try tuning down until the flat symbol is flashing, then tune up.
6. The green tuned symbol will light with happiness when you are tuned.
7. Repeat this for the other strings.
8. If you are trying to tune to a sharp, such as F#, then tune up until both the green tuned light and the tuned-sharp light come on.
9. Push the volume knob to turn the tuner off and restore the normal output.

# Changing the battery

The tuner has minimal battery power draw, and should provide many months of use. If you need to replace the battery, use the following steps:

- Depending on how it is installed, the battery can be accessed from the rear panel of your guitar or under the pick guard.
- Velcro strips hold the battery mounting clip in place inside the guitar.
- Remove the battery and carefully install a new one, making sure that the polarity is correct.
- Remove the battery if your guitar is not going to be used for long periods of time.

# Specifications

## Note Range

27 Hz to 3520 Hz (notes A0–A7)

## Accuracy

+/- 2 cents

## Input Source

Instrument pickups

## Battery Life

Estimated at one year's worth of tuning (approximately 600+ tunings). The tuner automatically powers down when not in use to conserve battery life

## Power Requirements

One 9V battery

## Physical Dimensions

Tuner Disc with LED circuit board

Height: 1.35"

Width: 1.35"

Depth: 0.12"

Potentiometer Body

Height: 0.98"

Width: 0.72"

Depth: 0.94"

# Warranty and repair

- If you suspect there is something wrong with your tuner, please contact us and we will try our best to help you.
- The patented *N-Tune* guitar tuning system carries a one year limited warranty. Visit our website for any warranty related issues. Proof of purchase may be required.

Please visit **[www.n-tune.com](http://www.n-tune.com)** for:

- Warranty Details
- Technical Support
- Alternative language instructions

- N-Tune is a trademark of Zero Crossing Inc. All other brands are trademarks or registered trademarks of their respective holders, and are hereby acknowledged.



Advanced Tuning Technology  
Built into the guitar!