

NIMBUS™

User Manual

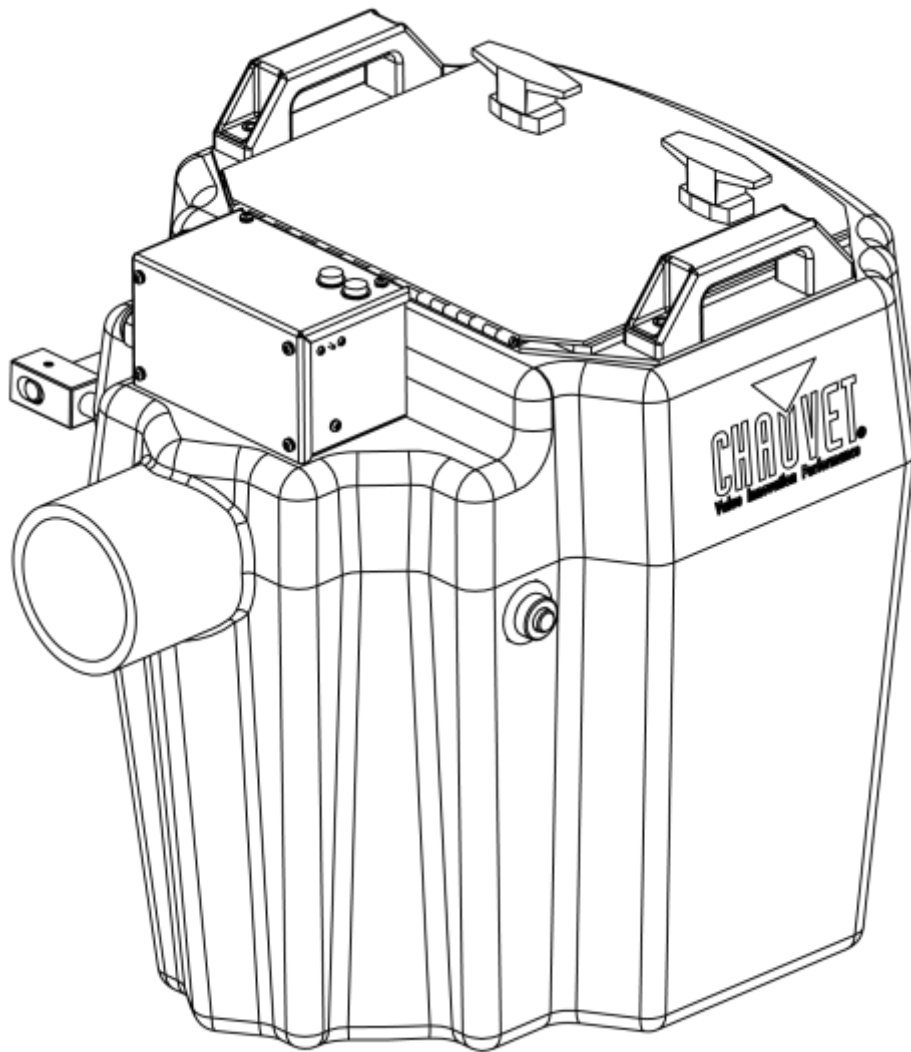

CHAUVET®
Value • Innovation • Performance

TABLE OF CONTENTS

1. Before You Begin	3
What Is Included	3
Unpacking Instructions	3
Claims	3
Text Conventions	3
Icons	3
Document Information	3
Safety Notes	4
2. Introduction	5
Product Overview	5
Product Dimensions	6
3. Setup	7
AC Power	7
About Dry Ice and CO ²	7
Dry Ice Warnings	7
4. Operation	8
Basic Instructions	8
Operation	8
5. Technical Information	9
Maintenance	9
General Troubleshooting	9
Contact Procedure	10
CHAUVET® Contact Information	10
Returning Products to CHAUVET®	10
6. Technical Specifications	11

1. BEFORE YOU BEGIN

What Is Included

- 1 x Nimbus™
- 1 x Power Cord
- 1 x Warranty Card
- 1 x Quick Reference Guide

Unpacking Instructions

Immediately upon receipt, carefully unpack the product and check the container to make sure you have received all the parts indicated above in good condition.

Claims



If the container or the material inside the container (the product and included accessories) appear damaged from shipping, or show signs of mishandling, notify the carrier immediately, not CHAUVET®, upon receipt. Failure to do so in a timely manner may invalidate your claim with the carrier. In addition, keep the container and all the packing material for inspection.

For other issues such as missing components or parts, damage not related to shipping, or concealed damage, file a claim with CHAUVET® within seven (7) days of receiving the merchandise.

Text Conventions

Convention	Meaning
1~512	A range of values
50/60	A set of values of which only one can be chosen
Settings	A menu option not to be modified
Menu > Settings	A sequence of menu options to be followed
<ENTER>	A key to be pressed on the product's control panel
ON	A value to be entered or selected

Icons

Icon	Meaning
	This paragraph contains critical installation, configuration, or operation information. Failure to comply with this information may render the product partially or completely inoperative, cause damage to the product, or cause harm to the user.
	This paragraph contains important installation or configuration information. Failure to comply with this information may prevent the product from functioning correctly.
	This paragraph reminds you of useful, although not critical, information.

Document Information

The information and specifications contained in this document are subject to change without notice. CHAUVET® assumes no responsibility or liability for any errors or omissions that may appear in this manual. CHAUVET® reserves the right to update the existing document or to create a new document to correct any errors or omissions.

You can download the latest version of this document from www.chauvetlighting.com.

© Copyright 2011 CHAUVET®. All rights reserved

Electronically published by CHAUVET® in the United States of America

Author	Date	Editor	Date
A. Diaz	09/30/11	B. Pillow	09/30/11

Safety Notes

Please read the following Safety Notes carefully before working with the product. The Notes include important safety information about installation, usage, and maintenance.



- Always connect the product to a grounded circuit to avoid the risk of electrocution.
- Always disconnect the product from the power source before cleaning.
- Make sure the power cord is not crimped or damaged.
- Never disconnect the product from power cord by pulling or tugging on the cord.
- Make sure there are no flammable materials close to the product when operating.
- Do not touch the product's housing when operating because it may be very hot.
- Do not mount the product on a flammable surface (linoleum, carpet, wood, paper, carton, plastic, etc.)
- The product's nozzle is very hot during operation and it remains hot for a long time after operation has stopped.
- The CO² exits the nozzle at a very high temperature. Keep a minimum distance of 6.5 ft (2 m) from the nozzle to the nearest object.
- Do not use the product as a space heater.
- Do not handle dry ice with bare hands. Thick gloves must be worn.
- Do not swallow dry ice. It may lead to severe internal injuries.
- Before breaking the dry ice, cover it with a piece of cloth or place the block in a cloth bag. Eye protection must be worn.
- Do not use in a confined space. Make sure the room is well ventilated before beginning usage.
- Dry ice should never be stored in a sealed container. It can lead to a pressure build-up and a risk of an explosion.



- For safety reasons, we do not recommend mounting the product in any capacity. Operate the product while it is on the ground only.
- During warm up and operation, water will be scolding hot. Do not place your hand into the water.
- Do not remove basket when the unit is plugged in or when heaters are hot.



- Always make sure that the voltage of the outlet to which you are connecting the product is within the range stated on the decal or rear panel of the product.
- The product is for indoor use only! (IP20) To prevent risk of fire or shock, do not expose the product to rain or moisture.
- Always install the product in a location with adequate ventilation, at least 20 in (50 cm) from adjacent surfaces.
- Be sure that no ventilation slots on the product's housing are blocked.
- Never connect the product to a dimmer.
- Never carry the product from the power cord or any moving part
- The maximum ambient temperature (Ta) is 104° F (40° C). Do not operate the product at higher temperatures.
- In the event of a serious operating problem, stop using the product immediately.
- Never try to repair the product. Repairs carried out by unskilled people can lead to damage or malfunction. Please contact the nearest authorized technical assistance center.
- Do not continue to use the machine once visibility is reduced to 20" (50cm) or below.
- Do not direct output continuously directly at anything within close proximity of the discharge nozzle.
- The area in front of the product may become wet during operation. Make sure not to use near smooth floors as they may become slippery.



- Water temperature should be about 175° F for optimal operation.
- Keep this User Manual for future consultation. If you sell the product to another user, be sure that they also receive this document.

2. INTRODUCTION

Product Overview

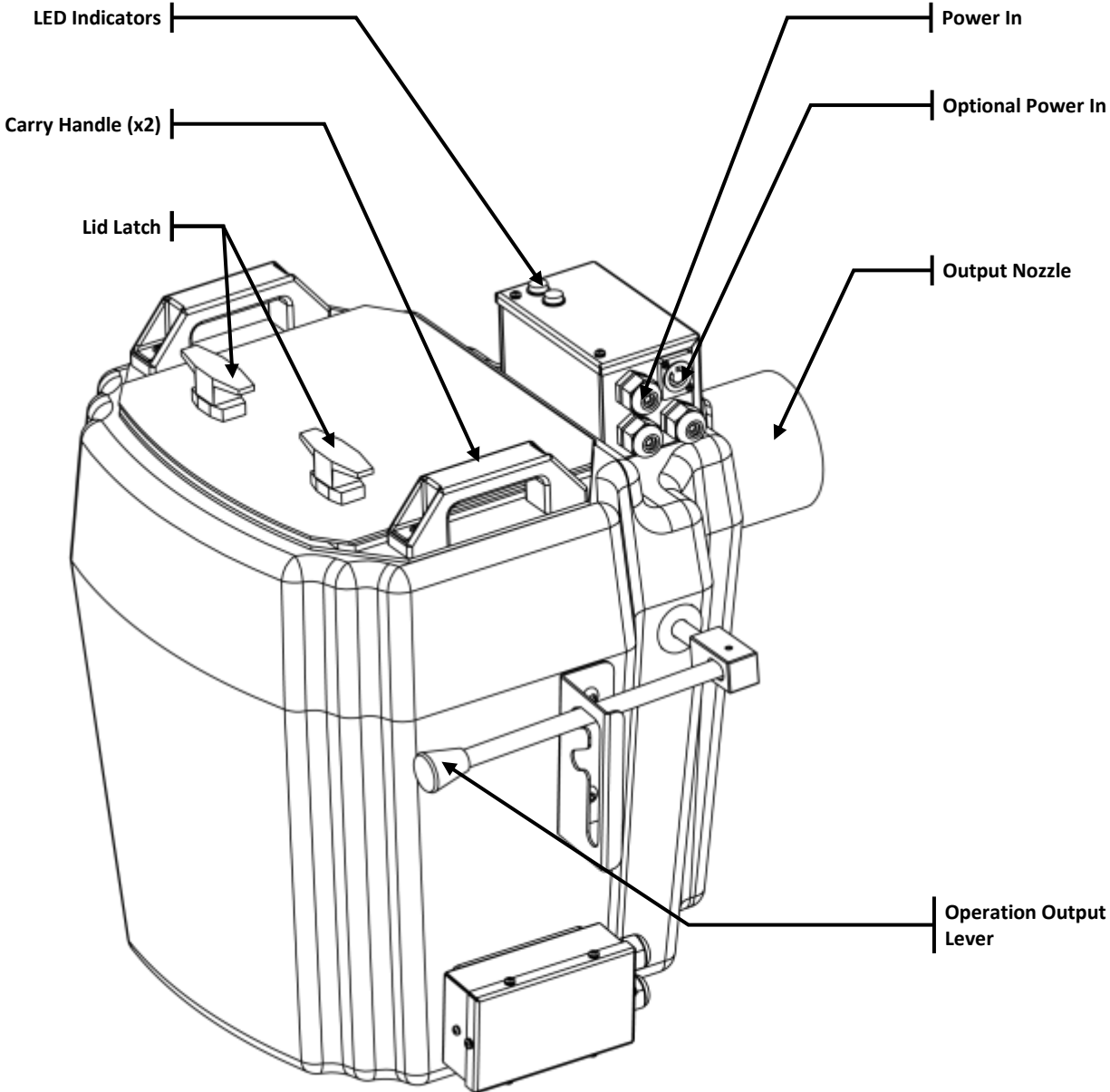

Product Dimensions

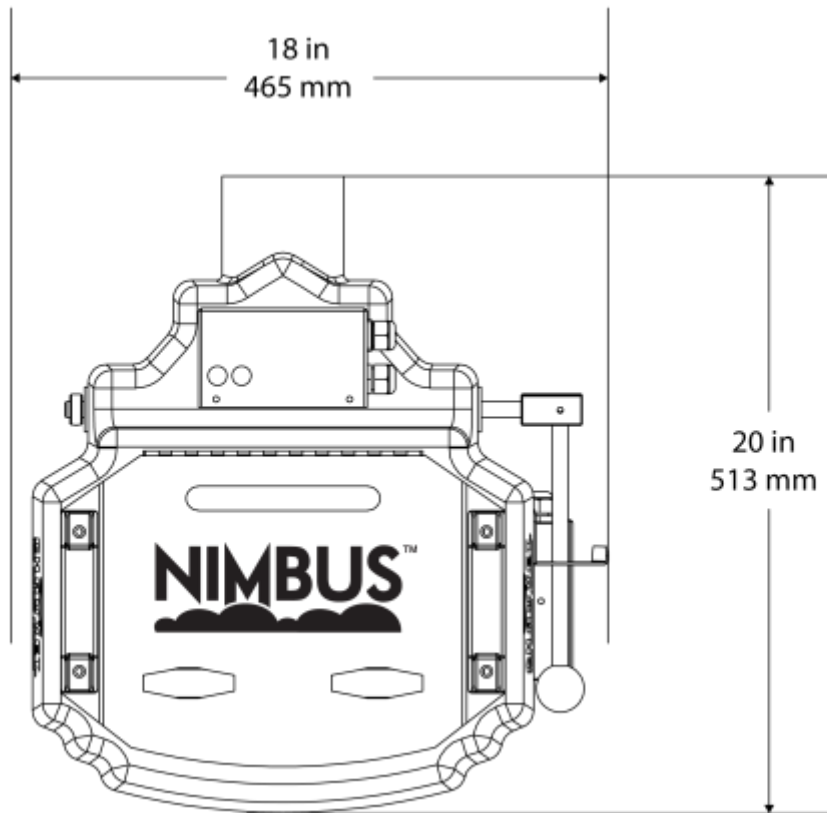
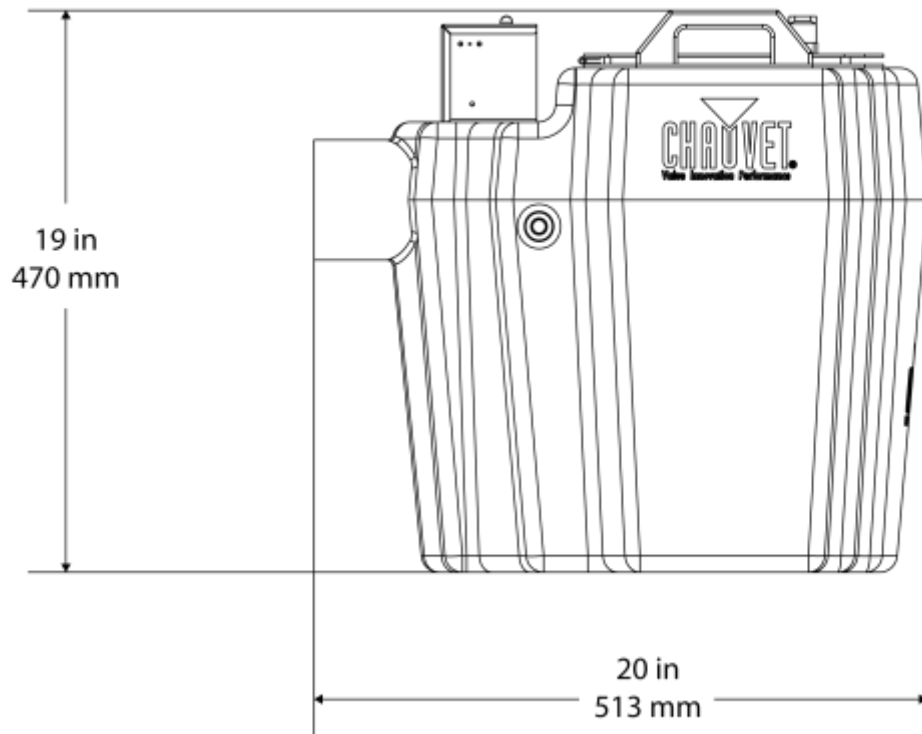

3. SETUP

AC Power The Nimbus™ has a fixed voltage power supply and can work with an input voltage of either 120 V, 60 Hz or 230 V, 50 Hz, depending on the specific model.

To determine the product's power requirements (circuit breaker, power outlet, and wiring), use the current value listed on the label affixed to the product's back panel, or refer to the product's specifications chart. The listed current rating indicates the product's average current draw under normal conditions.



Always connect the product to a protected circuit (circuit breaker or fuse). Make sure the product has an appropriate electrical ground to avoid the risk of electrocution or fire.



Never connect the product to a rheostat (variable resistor) or dimmer circuit, even if the rheostat or dimmer channel serves only as a 0 to 100% switch.

About Dry Ice and CO²

Dry ice is a solid form of carbon dioxide. The term “dry ice” is used because of its ability to sublime — the process of transforming from a solid directly to a gas without any liquid formation. Dry ice reaches a temperature of minus 189.5° F (-87.5° C).

When immersed in hot or boiling water, dry ice sublimates and agitates the water. The released cold CO² gas causes the water vapor to form water droplets in the air. This expansion of gas and moisture pushes its way out of the machine. Because the CO² is cold and heavy, the moisture sinks to the floor. The droplets in the air create the fog effect.

Dry Ice Warnings



- **DO NOT** cover or plug the output nozzle during operation. Compressing the dry ice will cause a chemical reaction that may lead to an explosion.
- Do not handle dry ice with bare hands. Thick gloves must be worn.
- Do not swallow dry ice. It will lead to severe internal injuries.
- Before breaking the dry ice, cover it with a piece of cloth or place the block in a cloth bag. Eye protection must be worn.
- Do not use in a confined space. Make sure the room is well ventilated before beginning usage.
- Dry ice should never be stored in a sealed container that can lead to a pressure build-up and a risk of an explosion.

4. OPERATION

Basic Instructions

- The top plate has two LED indicators – one red and one green. The red LED indicates that the heater is on, and the green LED indicates when the water is at its optimal operating temperature. The heater will not turn on unless there is enough water.
- As the dry ice sublimates, the green LED indicator will turn off indicating that the water temperature has dropped below its optimal operating temperature. This is normal and the Nimbus™ will continue to operate until all the dry ice has been used.
- During operation, the top plate becomes very hot. **DO NOT TOUCH!**
- There is an optional power input next to the main power input to increase the rate in which the water is heated. Use the included power cable and connect this secondary input to a separate circuit to heat the water in half the time. Do not plug both power cords into the same circuit as the breaker will trip.
- The dry ice must be stored inside the internal basket for optimal performance. Do not remove this basket as serious bodily injury may occur.

Operation

1. Place the machine on a level surface. Plug the power cord into the wall.
2. Raise the basket to its highest level with the operation lever.
3. Open the lid and fill with water until the red light comes on. The container can hold up to 4.5 gallons (17 liters).
4. Using protective gear, load the basket with up to 10 lbs of dry ice. The dry ice should be loaded at the last possible moment.
5. Close and latch the lid.
6. Grab the operating lever and slowly lower the handle to the middle notch for low output or all the way down for high output.
7. When output slows or stops, raise and refill the basket.



Due to water evaporation, you may need to refill the Nimbus™ with water to trigger the red light on. Once the red light comes on, repeat steps 4 through 7.

5. TECHNICAL INFORMATION

Maintenance The Nimbus requires minimal upkeep in order to maintain optimum performance. However, some steps are needed in order to clean and maintain the product for maximum usage. The recommended procedure is as follows:

1. After usage, wait for the machine to fully cool down.
2. Dump all water from the internal tank from the product.
3. If there is any water left over, wait until it has cooled down before transporting. You may risk bodily harm and damage to transport items if the water is still hot.

General Troubleshooting

Symptom	Possible Cause	Possible Action
Circuit breaker keeps blowing	<ul style="list-style-type: none">• Excessive load on the circuit	<ul style="list-style-type: none">• Make sure that the total load does not exceed 80% of the breaker or fuse nominal current
	<ul style="list-style-type: none">• Short circuit along the power lines	<ul style="list-style-type: none">• Check the power lines and power cords
Product does not power up	<ul style="list-style-type: none">• No energy on power outlet	<ul style="list-style-type: none">• Check power outlet• Change to another outlet
	<ul style="list-style-type: none">• Loose or damaged power cord	<ul style="list-style-type: none">• Check the power cord
	<ul style="list-style-type: none">• Internal problem	<ul style="list-style-type: none">• Send product for repair



If you still experience problems after trying the above solutions, contact CHAUVET® Technical Support.

Contact Procedure

In case you need to return a product or request support, follow the procedure below:

- If you live in the US, contact CHAUVET® World Headquarters (see below).
- If you live in the UK or Ireland, contact CHAUVET® Europe Ltd.(see below).
- If you live in any other country, DO NOT contact CHAUVET®. Instead, contact your distributor of record. Refer to our Web site for contact details of distributors outside the US, United Kingdom, or Ireland.

CHAUVET® Contact Information

World Headquarters

CHAUVET®

General Information

Address: 5200 NW 108th Avenue
Sunrise, FL 33351
Voice: (954) 929-1115
Fax: (954) 929-5560
Toll free: (800) 762-1084

Technical Support

Voice: (954) 929-1115 (Press 4)
Fax: (954) 756-8015
Email: tech@chauvetlighting.com

World Wide Web

www.chauvetlighting.com

United Kingdom & Ireland

CHAUVET® Europe Ltd.

General Information

Address: Unit 1C
Brookhill Road Industrial Estate
Pinxton, Nottingham, UK
NG16 6NT
Voice: +44 (0)1773 511115
Fax: +44 (0)1773 511110

Technical Support

Email: uktech@chauvetlighting.com

World Wide Web

www.chauvetlighting.co.uk



If you live outside the US, United Kingdom, or Ireland, contact your distributor of record and follow their instructions on how to return CHAUVET® products to them. Visit our Web site for contact details.

Returning Products to CHAUVET®

Call the corresponding CHAUVET® Tech Support office and request a Return Merchandise Authorization (RMA) number before shipping the product. Be prepared to provide the model number, serial number, and a brief description of the cause for the return.

You must send the merchandise prepaid, in its original box, and with its original packing and accessories. CHAUVET® will not issue call tags.

Clearly label the package with the RMA number. CHAUVET® will refuse any product returned without an RMA number.



Write the RMA number on a properly affixed label. DO NOT write the RMA number directly on the box.

Before sending the product, clearly write the following information on a piece of paper and place it inside the box:

- Your name
- Your address
- Your phone number
- The RMA number
- A brief description of the problem

Be sure to pack the product properly. Any shipping damage resulting from inadequate packaging will be your responsibility. As a suggestion, proper UPS packing or double-boxing is always a safe method to use.



CHAUVET® reserves the right to use its own discretion to repair or replace returned product(s).

6. TECHNICAL SPECIFICATIONS

Dimensions and Weight

Length	Width	Height	Weight
20 in (513 mm)	18 in (465 mm)	19 in (470 mm)	Empty: 28.6 lbs (13 kg) Full: 75 lbs (34 kg)

Note: Dimensions in inches rounded to the nearest decimal digit.

Power

Power Supply Type	Range	Voltage Selection
Model specific	120 V, 60 Hz or 230 V, 50 Hz	Voltage specific

Parameter	Single Element	Dual Element
Consumption	1500 W	3000 W
Operating	12.6 A	25.2 A

Power I/O	US/Worldwide	UK/Europe
Power input connector	Neutrik® powerCON® A	Neutrik® powerCON® A

Heat

Parameter	Heat Up Time	Reheat Time
Single Element	50 min	30 min
Dual Element	30 min	15 min

Average Runtime	Tank Capacity	Dry Ice Capacity
6 min	4.5 gal (17 l)	10 lbs (4.5 kg)

Thermal

Maximum External Temp.	Max Water Temperature
104° F (40° C)	175° F (79° C)

Ordering

Product Name	Item Code	Item Number
Nimbus™ (120 V)	09050429	NIMBUS
Nimbus™ (220 V)	09050451	220VNIMBUS

