

RØDE[®]
MICROPHONES



**The
BROADCASTER
Instruction Guide**



RØDE STUDIO CONDENSER MICROPHONES

BROADCASTER

Serial Number:

Checked by:

Date:

Thank you for purchasing the **RØDE BROADCASTER**.

To achieve the best performance, and to obtain a lifetime of service, we urge you to spend a few minutes reading this manual.

You have joined thousands of other satisfied customers world-wide who choose and recommend **RØDE** above any other make, regardless of price.

As a **RØDE** customer, you are very important to us. We have a world-wide distributor and dealer network. If however, you cannot get the assistance or advice you need, please do not hesitate to contact me directly.

Company History

RØDE is the main manufacturing division of Freedman Electronics. Freedman Electronics was founded by Henry and Astrid Freedman in 1966 after emigrating from Sweden where Henry's long and illustrious audio career began.

The company is based in Sydney Australia, home of the 2000 Olympic games. Electronics design, testing and manufacturing is performed at this facility. The Engineering of the metal work is performed at a dedicated C.N.C. facility located 250 km from the city.

We hope you are and will continue to be satisfied with your purchase.



Peter Freedman

RØDE Australia

SPECIFICATIONS:

- 1" Gold Sputtered Pressure Gradient Transducer
- Frequency Response: 20 Hz –20 kHz
- Noise: 14dB (A)
- Sensitivity: 18 mV/Pa
- Max SPL: 135dB
- Low Cut Filter: @ 75Hz 6dB/octave
- Output Impedance: 200 ohms
- Power Requirement: +48V DC Phantom
- Current Consumption: 5 mA

Features:

- True Large Diaphragm Condenser Capsule
- On-Air Indicator
- Ultra Low-Noise
- Cardioid Polar Pattern with high 180° rejection
- Voice Tailored Low Cut Filter
- Internal Pop Filter
- Internally Shock-Mounted Capsule
- Rugged Stainless Steel Body

Accessories:

- BM1 Microphone Holder
- Custom High Impact Carry Case
- 5 Pin Plug



1. You will need a power supply to operate the BROADCASTER. For optimum results, this should be a 48V D.C. Phantom.
Most professional consoles have an internal 48V supply, or you can purchase one separately. Make sure the power supply you use is a professional unit that is operating correctly. Damage caused by connecting the BROADCASTER to a faulty power supply is not covered by the guarantee.
2. The BROADCASTER comes complete with a Micro-phone Mount (BM 1) and this must be used to attach the BROADCASTER to a 'stable' microphone stand.
3. When first connecting the BROADCASTER we suggest that you have the Gain control adjusted to FULL attenuation (OFF).
4. Please make all cable connections before applying power to the microphone. Never remove the microphone cable while the power is connected.
5. Check that you have the BROADCASTER correctly connected. You can connect the microphone directly to the mixer (without an external supply) if 48V is available on the mixer.

Always use a balanced microphone cable and be sure that the cable is a wired Pin 1 screen, Pin 2+ Pin 3-, and 4 and 5 to switch the On-Air indicator if used (refer to Wiring Diagram).

We suggest you purchase a cable with gold-plated plugs, as contact resistance due to corrosion is a major cause of problems in all sound systems.

6. Switch on the Power Supply/Mixer. The Microphone will take a few seconds to stabilize. Adjust the mixer gain so that the Peak Programme light on the console 'flashes' on the 'peaks' of the sound source (Voice). Be sure to do this at the same SPL (volume) and distance you (or the announcer) will work at. The BROADCASTER is now ready for use.

7. Microphone technique, or how to get the sound you want, requires experimentation. Moving closer to the microphone increases the perceived 'warmth' and 'bass' (Proximity Effect). Try to get the sound you want by placing either reflective or absorbent panels at various angles adjacent to the source. Changing the acoustic properties of the space the microphone is in, is our recommended initial approach for obtaining the best sound quality.

The BROADCASTER 'ON-AIR' INDICATOR:

While the BROADCASTERS' output connection and On-Air Indicator control is a very simple operation to perform, we suggest that unless you are familiar with cable connections and audio installations in general, that you have an Audio/Electronics Technician perform this task to assure optimum performance.

The On-Air Indicator L.E.D. is switched either On or Off by applying an open or closed circuit across Pins 4 and 5 of the output connector.

When 'open circuit' (no connections across Pins 4 and 5), the L.E.D. is active. If you do not wish to switch the L.E.D. via a console or separate mute button, then the L.E.D. will be active continuously whenever the microphone has P48V (Phantom Power) applied.

Most professional consoles have switches that provide both open circuit or short circuit outputs. These are usually called 'Channel On' or 'Channel Mute' controls and actually mute the audio signal as well as providing external contacts. These external contacts are usually used to mute audio monitors and switch On-Air lights at the same time as microphones become active. These contacts can also be used to activate the BROADCASTERS' 'On-Air' indicator.

Remember, the L.E.D. does not interfere with the audio circuit, and has no other function than that of an indicator. The microphone does not mute itself! The indicator is simply that; an indicator of the status of what another device is doing. (Console Muting).

A 5 Pin female connector is supplied, and you can use a four-core screened (Quad) microphone cable which is readily available from most professional audio suppliers, or you can use any cable which is a two-core screened plus 2 extra control wires if the L.E.D is to be switched.

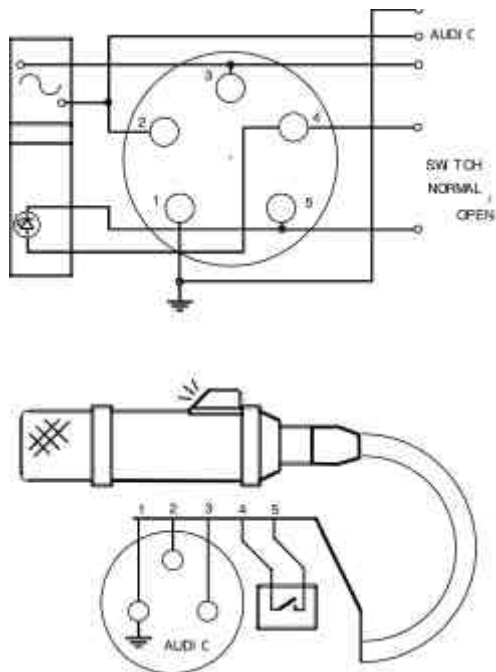

Some tips that may be helpful:

1. Condenser microphones do not like moisture! The BROADCASTER, like all studio microphones should be kept dry at all times.

The BROADCASTER is a precision transducer and should be cared for as such. Dropping or knocking the microphone can damage it and so please ensure that the microphone is securely fixed to a dedicated microphone stand using the BM1 Mount supplied.

*After every use, the BROADCASTER should be removed from its stand, wiped down with a dry soft cloth, and placed in its case. Be sure to place the moisture-absorbent crystals (small pouch) at the head of the microphone. The crystals will absorb any moisture present. Eventually, this pack needs to be dried. When the crystals have turned pink, the pack should be placed in an oven set to between 100-150°C. They will be activated when they turn blue.

Note: There are no user serviceable parts inside this microphone, and so there will never be a reason for you to dismantle it. All service that requires dismantling must be performed by a qualified RØDE service agent to protect your warranty.

Warranty Service:

All **RØDE** products are warranted for one year from date of purchase and the warranty card should be used to register that purchase.

The warranty covers parts and labour that may be required to repair the microphone during the warranty period. The warranty excludes defects caused by normal wear and tear, modification, shipping damage, or failure to use the microphone as per the instruction guide.

If you experience any problem, or have any questions regarding your **RØDE** microphone, first, contact the Dealer who sold it to you. If the microphone requires Factory authorised service, return will be organised by that Dealer. We have an extensive Distributor/Dealer network, but if you have difficulty getting the advice or assistance you require, do not hesitate to contact us directly.

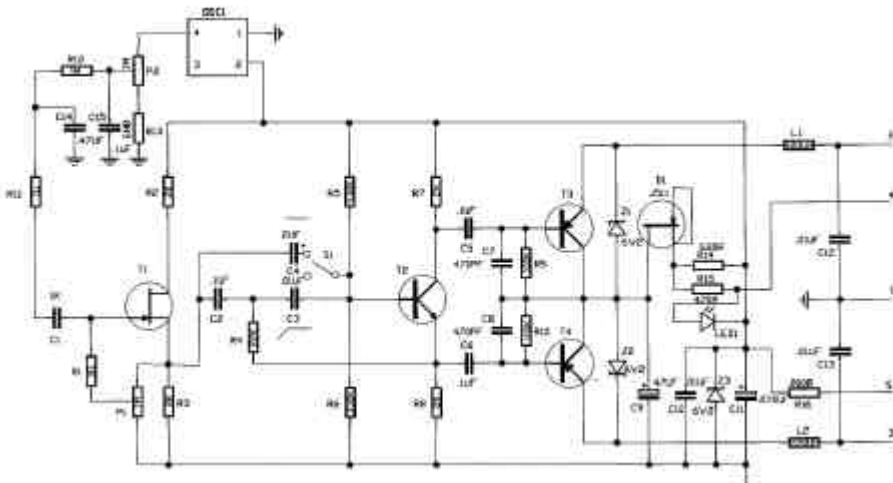

International: Tel: 61 -2 8765 9333
 Fax: 61 -2 8765 9444

Australia: Tel: (02) 8765 9333
 Fax: (02) 8765 9444

USA: Tel: 310-328-7456
 Fax: 310-328-7180

e-mail information: info@rodemicphones.com
 www.rodemicphones.com

or contact your local **RØDE** Distributor