

Derby X™

Snapshot

OK on Dimmer	⊘
Outdoor OK	⊘
Sound Activated	✓
DMX512	✓
Master/Slave	✓
Autoswitching Transformer	✓
Replaceable Fuse	✓
User Serviceable	⊘
Duty Cycle	⊘

USER MANUAL

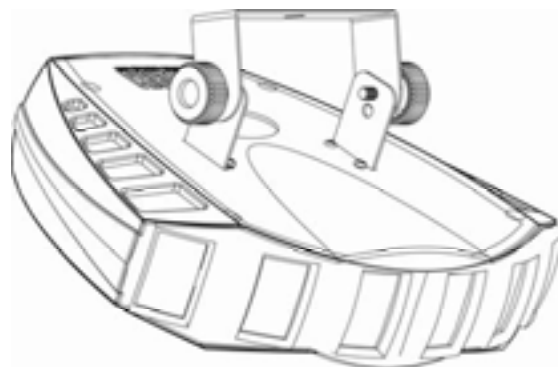

3000 N 29th Ct, Hollywood, FL 33020 U.S.A.
(800) 762-1084 – (954) 929-1115
FAX (954) 929-5560
www.chauvetlighting.com

TABLE OF CONTENTS

1. Before You Begin	3
What is included.....	3
Unpacking Instructions.....	3
AC Power	3
Contact Us	3
Safety Instructions.....	4
2. Introduction	5
Features	5
DMX Channel Summary	5
Product Overview.....	5
3. Setup	6
Fuse Replacement.....	6
Fixture Linking.....	6
Data Cabling	6
DMX Data Cable	6
Cable Connectors	7
3-Pin to 5-Pin Conversion Chart	7
Setting up a DMX Serial Data Link.....	7
Master/Slave Fixture Linking.....	8
Mounting	8
Orientation.....	8
Rigging.....	8
Stacking	9
4. Operating Instructions	10
Operation	10
Stand-Alone Mode (Sound-Active):.....	10
Master/Slave Mode (Master Sound):	10
DMX Mode	10
DMX Channel Values.....	11
Setting the starting address	12
DMX Quick Reference Chart.....	13
Blow-out Diagram.....	14
General Troubleshooting.....	15
Technical Support	16
5. Appendix	16
DMX Primer.....	16
General Maintenance.....	17
Returns Procedure	17
Claims	17
Technical Specifications.....	18

1. BEFORE YOU BEGIN

What is included

- 1 x Derby X™
- Power Cord
- Warranty Card
- User Manual

Unpacking Instructions

Immediately upon receiving a fixture, carefully unpack the carton, check the contents to ensure that all parts are present, and have been received in good condition. Notify the shipper immediately and retain packing material for inspection if any parts appear damaged from shipping or the carton itself shows signs of mishandling. Save the carton and all packing materials. In the event that a fixture must be returned to the factory, it is important that the fixture be returned in the original factory box and packing.

AC Power

This fixture has an auto-switching power supply that can accommodate a wide range of input voltages. The only thing necessary to do before powering on the unit is to make sure the line voltage you are applying is within the range of accepted voltages. This fixture will accommodate between 100V and 240V AC 50-60 Hz. All fixtures must be powered directly off a switched circuit and cannot be run off a rheostat (variable resistor) or dimmer circuit, even if the rheostat or dimmer channel is used solely for a 0% to 100% switch.

Contact Us

World Wide

General Information CHAUVET
3000 North 29th Court
Hollywood, FL 33020
voice: 954.929.1115
fax: 954.929.5560
toll free: 800.762.1084

Technical Support CHAUVET
3000 North 29th Court
Hollywood, FL 33020
voice: 954.929.1115 **(Press 4)**
fax: 954.929.5560 **(Attention: Service)**

World Wide Web www.chauvetlighting.com

Safety Instructions



Please read these instructions carefully, which includes important information about the installation, usage and maintenance of this product.

- Please keep this User Guide for future consultation. If you sell the unit to another user, be sure that they also receive this instruction booklet.
- Always make sure that you are connecting to the proper voltage, and that the line voltage you are connecting to is not higher than that stated on the decal or rear panel of the fixture.
- This product is intended for indoor use only! (If applicable)
- To prevent risk of fire or shock, do not expose fixture to rain or moisture. Make sure there are no flammable materials close to the unit while operating.
- The unit must be installed in a location with adequate ventilation, at least 20in (50cm) from adjacent surfaces. Be sure that no ventilation slots are blocked.
- Always disconnect from power source before servicing or replacing lamp or fuse and be sure to replace with same lamp source.
- Secure fixture to fastening device using a safety chain. Never carry the fixture solely by its head. Use its carrying handles.
- Maximum ambient temperature (Ta) is 104°F (40°C). Do not operate fixture at temperatures higher than this.
- In the event of a serious operating problem, stop using the unit immediately. Never try to repair the unit by yourself. Repairs carried out by unskilled people can lead to damage or malfunction. Please contact the nearest authorized technical assistance center. Always use the same type spare parts.
- Never connect the device to a dimmer pack.
- Make sure the power cord is never crimped or damaged.
- Never disconnect the power cord by pulling or tugging on the cord.
- Avoid direct eye exposure to the light source while it is on.
- Do not daisy chain power to more than # units. (If applicable)

Caution! *There are no user serviceable parts inside the unit. Do not open the housing or attempt any repairs yourself. In the unlikely event your unit may require service, please contact CHAUVET at: 954-929-1115.*

2. INTRODUCTION

Features

- 8-channel DMX-512 LED derby effect
- Blackout/static/strobe
- Individual control of red, green and blue LEDs within each cluster (6 total)
- Built-in automated programs via DMX
- Built-in sound activated programs via master/slave or DMX

Additional Features

- Mount multiple units together with adjustable, optional bracket (XBRACKET)
- Additional power output: max 27 units @ 120V (see manual for details)

DMX Channel Summary

Channel	Description
1	Led Cluster 1
2	Led Cluster 2
3	Led Cluster 3
4	Led Cluster 4
5	Led Cluster 5
6	Led Cluster 6
7	Strobe
8	Auto Programs

Product Overview

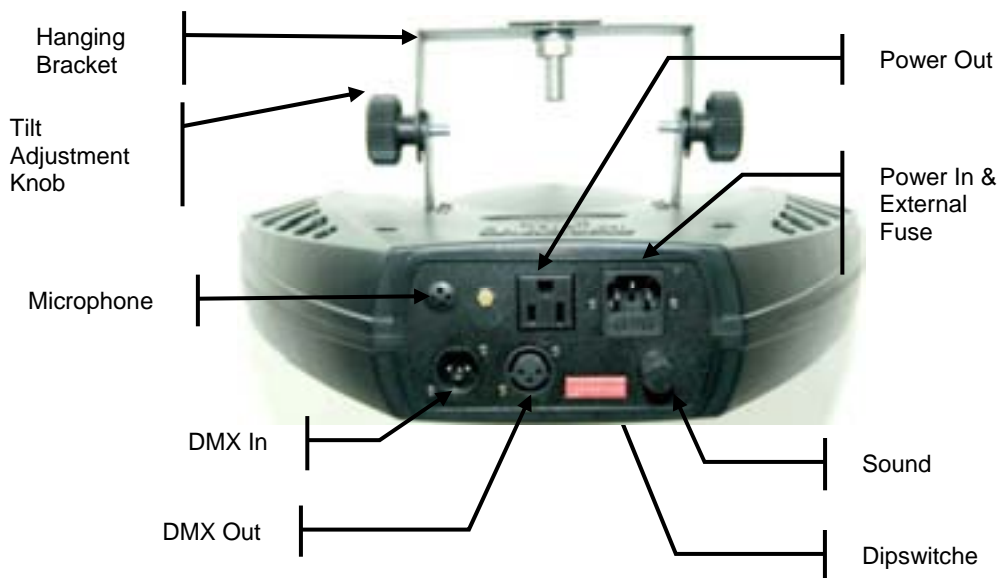

3. SETUP

Fuse Replacement



Disconnect the power cord before replacing a fuse and always replace with the same type fuse.



With a flat head screwdriver wedge the fuse holder out of its housing. Remove the damaged fuse from its holder and replace with exact same type fuse. Insert the fuse holder back in its place and reconnect power.

The fuse is located inside this compartment. Remove using a flat head screwdriver.

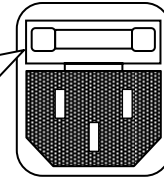

Fixture Linking

You will need a serial data link to run light shows of one or more fixtures using a DMX-512 controller or to run synchronized shows on two or more fixtures set to a master/slave operating mode. The combined number of channels required by all the fixtures on a serial data link determines the number of fixtures the data link can support.

Important: Fixtures on a serial data link must be daisy chained in one single line. To comply with the EIA-485 standard no more than 32 devices should be connected on one data link. Connecting more than 32 fixtures on one serial data link without the use of a DMX optically-isolated splitter may result in deterioration of the digital DMX signal.

Maximum recommended serial data link distance: 500 meters (1640 ft.)

Maximum recommended number of fixtures on a serial data link: 32 fixtures

Data Cabling

To link fixtures together you must obtain data cables. You can purchase CHAUVET-certified DMX cables directly from a dealer/distributor or construct your own cable. If you choose to create your own cable please use data-grade cables that can carry a high quality signal and are less prone to electromagnetic interference.

DMX DATA CABLE

Use a Belden© 9841 or equivalent cable which meets the specifications for EIA RS-485 applications. Standard microphone cables cannot transmit DMX data reliably over long distances. The cable will have the following characteristics:

2-conductor twisted pair plus a shield

Maximum capacitance between conductors – 30 pF/ft.

Maximum capacitance between conductor and shield – 55 pF/ft.

Maximum resistance of 20 ohms / 1000 ft.

Nominal impedance 100 – 140 ohms

CABLE CONNECTORS

Cabling must have a male XLR connector on one end and a female XLR connector on the other end.

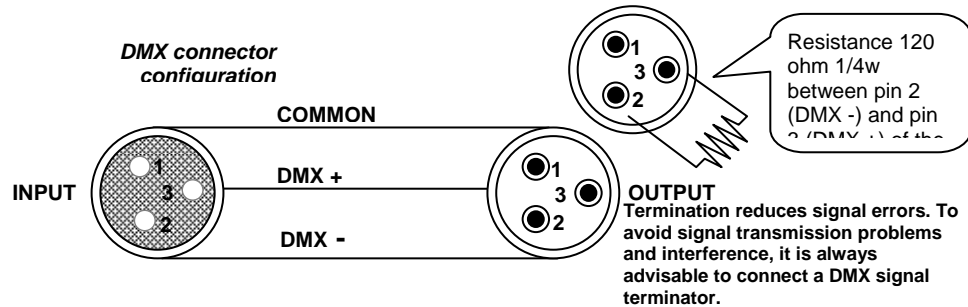

CAUTION Do not allow contact between the common and the fixture's chassis ground. Grounding the common can cause a ground loop, and your fixture may perform erratically. Test cables with an ohm meter to verify correct polarity and to make sure the pins are not grounded or shorted to the shield or each other.

3-PIN TO 5-PIN CONVERSION CHART

Note! If you use a controller with a 5 pin DMX output connector, you will need to use a 5 pin to 3 pin adapter. CHAUVET Model No: DMX5M, or DMX5F.

The chart below details a proper cable conversion:

3 PIN TO 5 PIN CONVERSION CHART

Conductor	3 Pin Female (output)	5 Pin Male (Input)
Ground/Shield	Pin 1	Pin 1
Data (-) signal	Pin 2	Pin 2
Data (+) signal	Pin 3	Pin 3
Do not use		Do not use
Do not use		Do not use

Setting up a DMX Serial Data Link

1. Connect the (male) 3 pin connector side of the DMX cable to the output (female) 3 pin connector of the controller.
2. Connect the end of the cable coming from the controller which will have a (female) 3 pin connector to the input connector of the next fixture consisting of a (male) 3 pin connector.
3. Then, proceed to connect from the output as stated above to the input of the following fixture and so on.

CHAUVET Certified DMX Data Cables

Order Code	Description
DMX1.5	DMX Cable 1.5m/4.9ft
DMX4.5	DMX Cable 4.5m/14.8ft
DMX10	DMX Cable 10m/32.8ft

Universal DMX Controller

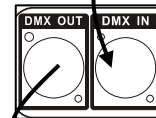
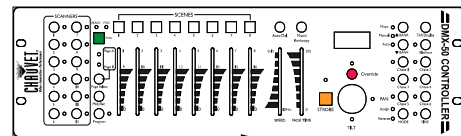

This drawing provides a general illustration of the DMX Input/Output panel of a lighting fixture.

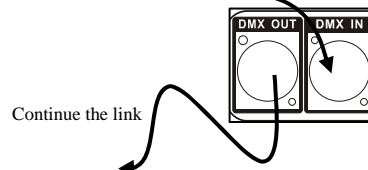

Master/Slave Fixture Linking

1. Connect the (male) 3 pin connector side of the DMX cable to the output (female) 3 pin connector of the first fixture.
2. Connect the end of the cable coming from the first fixture which will have a (female) 3 pin connector to the input connector of the next fixture consisting of a (male) 3 pin connector. Then, proceed to connect from the output as stated above to the input of the following fixture and so on.

Often, the setup for Master-Slave and Standalone operation requires that the first fixture in the chain be initialized for this purpose via either settings in the control panel or DIP-switches. Secondly, the fixtures that follow may also require a slave setting. Please consult the "Operating Instructions" section in this manual for complete instructions for this type of setup and configuration.

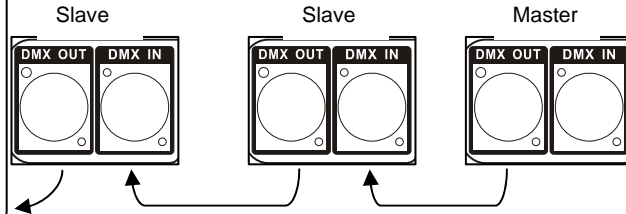

Mounting

ORIENTATION

This fixture may be mounted in any safe position provided there is adequate room for ventilation.

RIGGING

It is important never to obstruct the fan or vents pathway. Mount the fixture using, a suitable "C" or "O" type clamp. Adjust the angle of the fixture by loosening both knobs and tilting the fixture. After finding the desired position, retighten both knobs.

- When selecting installation location, take into consideration lamp replacement access and routine maintenance.
- Safety cables must always be used.
- Never mount in places where the fixture will be exposed to rain, high humidity, extreme temperature changes or restricted ventilation.

Hanging Clamp

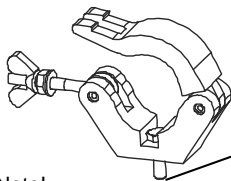

Note!
Clamp is sold separately.



Stacking

The Derby X™ may be “stacked” by using multiple fixtures and the optional bracket (XBRACKET). This bracket may be ordered from CHAUVET.

The bracket kit will ship with 2pcs bracket (as shown below) and will include 4 screws for attaching it to the bottom of the fixture.

- *Note: When you are installing this bracket, you must use the washers and bracket tightening knob to secure one fixture to another.*
- *Note: You must only stack a maximum of 4 fixtures.*

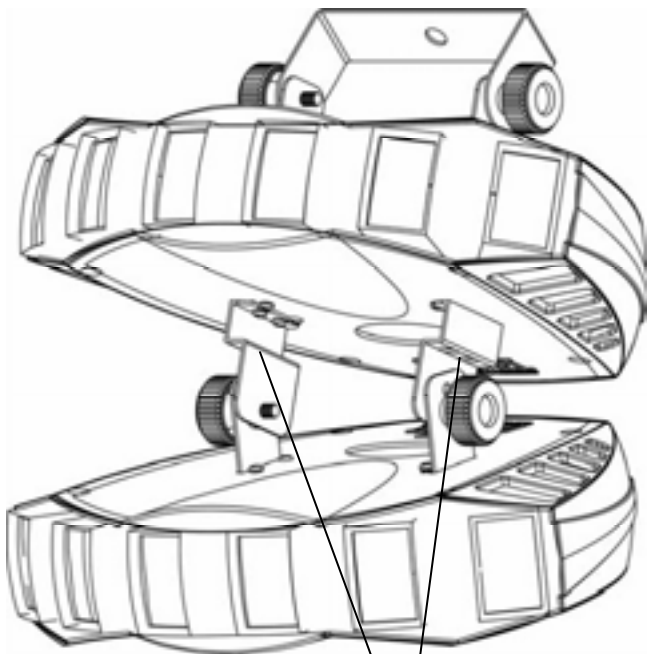

Optional XBRACKET

4. OPERATING INSTRUCTIONS

Operation

Stand-Alone Mode (Sound-Active):

This mode allows a single unit to run to the beat of the music, or the unit will auto change in Auto Mode.

- 1) Set all dipswitches position to the **Off** position.

Mode	Dipswitches
Sound Active	10 = Off

- 2) The unit will react to the low frequencies of music via the internal microphone in Sound Active mode.
- 3) Use the audio sensitivity knob on the back of the unit to make the unit more or less sensitive in Sound-Active mode. Turning the knob counterclockwise decreases the sensitivity; turning the knob clockwise increases the sensitivity.

Master/Slave Mode (Master Sound):

This mode will allow you to link up to 32 units together without a controller.

- 1) Use standard DMX cables to daisy chain your units together via the DMX connector on the rear of the units. For longer cable runs we suggest a terminator at the last fixture. For more information about terminators, see page 7.
- 2) Choose a unit to function as the Master. Turn dipswitches to the Master position on the unit. The unit must be the first unit in line. Then simply chain the units together using DMX cable.

Mode	Dipswitches
Master Sound	10 = Off

- 3) Turn switch to the Slave position on the slave units, and they will react the same as the Master.

Mode	Dipswitches
Slave	1 = On, 10 = On

DMX Mode

This mode allows the unit to be controlled by any universal DMX controller. If you are unfamiliar with DMX, please read the DMX Primer on page 16.

- 1) Set the dipswitches to DMX mode.

Mode	Dipswitches
DMX	10 = On

- 2) Connect a DMX controller to the fixture.
- 3) Set the start address according to standard binary code.
 - a. Note: If you are unfamiliar with DMX addressing, we suggest you refer to the section on *DMX Primer*.

DMX Channel Values

Channel	Value	Function
1		Cluster Control
	000 ⇔ 010	No Function
2	011 ⇔ 045	Red
3	046 ⇔ 080	Green
	081 ⇔ 115	Blue
4	116 ⇔ 150	Red/Green
5	151 ⇔ 185	Red/Blue
	186 ⇔ 220	Green/Blue
6	221 ⇔ 255	Red/Green/Blue
7		Strobe
	000 ⇔ 010	No Function
	011 ⇔ 255	Strobe 0%~100%
8		Auto Speed
	000 ⇔ 010	No Function
	011 ⇔ 024	Auto 1
	025 ⇔ 038	Auto 2
	039 ⇔ 052	Auto 3
	053 ⇔ 066	Auto 4
	067 ⇔ 080	Auto 5
	081 ⇔ 094	Auto 6
	095 ⇔ 108	Auto 7
	109 ⇔ 122	Auto 8
	123 ⇔ 136	Auto 9
	137 ⇔ 150	Auto 10
	151 ⇔ 164	Auto 11
	165 ⇔ 178	Auto 12
	179 ⇔ 192	Auto 13
	193 ⇔ 206	Auto 14
	207 ⇔ 220	Auto 15
	221 ⇔ 250	Auto 16
	251 ⇔ 255	Audio Trigger

SETTING THE STARTING ADDRESS

This DMX mode enables the use of a universal DMX controller device. Each fixture requires a "start address" from 1 to 512. A fixture requiring one or more channels for control begins to read the data on the channel indicated by the start address. For example, a fixture that uses 6 DMX channels and was addressed to start on DMX channel 100, would read data from channels: 100, 101, 102, 103, 104, and 105. Choose start addresses so that the channels used do not overlap, and note the start address selected for future reference.

If this is your first time addressing a fixture using the DMX-512 control protocol, we suggest jumping to the Appendix Section and reading the heading "DMX Primer". It contains very useful information that will help you understand its use.

Set the start address using the group of DIP switches located usually on bottom of the fixture. Each dip switch has an associated value. Adding the value of each switch in the ON position will provide the start address. Figuring out which switches to toggle ON given a specific start address can be accomplished by determining which switch values will add up to the address value and turning these switches on. Do so by doing the following:

- 1) Determine the largest value switch that is less than the start address. Turn this switch on.
- 2) Subtract the value of the switch you just turned on from the starting address number.
- 3) Determine the largest value switch that is less than the remainder from the previous subtraction. Turn this switch on.
- 4) Subtract the value of the switch you just turned on from the remainder of the previous subtraction.
- 5) Repeat steps three and four until you have a remainder of zero.

Example Starting Address

<p>Address 10</p> <p>Switch # 4 = 8 Switch # 2 = 2 Total = 10</p>	<p>256 128 64 32 16 8 4 2 1</p> <p>9 8 7 6 5 4 3 2 1</p>																				
<p>Address 24</p> <p>Switch # 5 = 16 Switch # 4 = 8 Total = 24</p>	<p>256 128 64 32 16 8 4 2 1</p> <p>9 8 7 6 5 4 3 2 1</p>																				
<p>Resolving address using simple math.</p> <p>Address 233</p>	<table border="1"> <thead> <tr> <th>DIPSWITCH</th> <th>(DMX VALUE)</th> </tr> </thead> <tbody> <tr><td>1</td><td>1</td></tr> <tr><td>2</td><td>2</td></tr> <tr><td>3</td><td>4</td></tr> <tr><td>4</td><td>8</td></tr> <tr><td>5</td><td>16</td></tr> <tr><td>6</td><td>32</td></tr> <tr><td>7</td><td>64</td></tr> <tr><td>8</td><td>128</td></tr> <tr><td>9</td><td>256</td></tr> </tbody> </table>	DIPSWITCH	(DMX VALUE)	1	1	2	2	3	4	4	8	5	16	6	32	7	64	8	128	9	256
DIPSWITCH	(DMX VALUE)																				
1	1																				
2	2																				
3	4																				
4	8																				
5	16																				
6	32																				
7	64																				
8	128																				
9	256																				

DMX QUICK REFERENCE CHART

DMX Address Quick Reference Chart																				
Dip Switch Position																				
DMX DIP SWITCH SET 0=OFF 1=ON X=OFF or ON	#9	0	0	0	0	0	0	0	0	1	1	1	1	1	1	1				
	#8	0	0	0	0	1	1	1	1	0	0	0	0	1	1	1				
	#7	0	0	1	1	0	0	1	1	0	0	1	1	0	0	1				
	#6	0	1	0	1	0	1	0	1	0	1	0	1	0	1	0				
#1	#2	#3	#4	#5																
0	0	0	0	0	32	64	96	128	160	192	224	256	288	320	352	384	416	448	480	
1	0	0	0	0	1	33	65	97	129	161	193	225	257	289	321	353	385	417	449	481
0	1	0	0	0	2	34	66	98	130	162	194	226	258	290	322	354	386	418	450	482
1	1	0	0	0	3	35	67	99	131	163	195	227	259	291	323	355	387	419	451	483
0	0	1	0	0	4	36	68	100	132	164	196	228	260	292	324	356	388	420	452	484
1	0	1	0	0	5	37	69	101	133	165	197	229	261	293	325	357	389	421	453	485
0	1	1	0	0	6	38	70	102	134	166	198	230	262	294	326	358	390	422	454	486
1	1	1	0	0	7	39	71	103	135	167	199	231	263	295	327	359	391	423	455	487
0	0	0	1	0	8	40	72	104	136	168	200	232	264	296	328	360	392	424	456	488
1	0	0	1	0	9	41	73	105	137	169	201	233	265	297	329	361	393	425	457	489
0	1	0	1	0	10	42	74	106	138	170	202	234	266	298	330	362	394	426	458	490
1	1	0	1	0	11	43	75	107	139	171	203	235	267	299	331	363	395	427	459	491
0	0	1	1	0	12	44	76	108	140	172	204	236	268	300	332	364	396	428	460	492
1	0	1	1	0	13	45	77	109	141	173	205	237	269	301	333	365	397	429	461	493
0	1	1	1	0	14	46	78	110	142	174	206	238	270	302	334	366	398	430	462	494
1	1	1	1	0	15	47	79	111	143	175	207	239	271	303	335	367	399	431	463	495
0	0	0	0	1	16	48	80	112	144	176	208	240	272	304	336	368	400	432	464	496
1	0	0	0	1	17	49	81	113	145	177	209	241	273	305	337	369	401	433	465	497
0	1	0	0	1	18	50	82	114	146	178	210	242	274	306	338	370	402	434	466	498
1	1	0	0	1	19	51	83	115	147	179	211	243	275	307	339	371	403	435	467	499
0	0	1	0	1	20	52	84	116	148	180	212	244	276	308	340	372	404	436	468	500
1	0	1	0	1	21	53	85	117	149	181	213	245	277	309	341	373	405	437	469	501
0	1	1	0	1	22	54	86	118	150	182	214	246	278	310	342	374	406	438	470	502
1	1	1	0	1	23	55	87	119	151	183	215	247	279	311	343	375	407	439	471	503
0	0	0	1	1	24	56	88	120	152	184	216	248	280	312	344	376	408	440	472	504
1	0	0	1	1	25	57	89	121	153	185	217	249	281	313	345	377	409	441	473	505
0	1	0	1	1	26	58	90	122	154	186	218	250	282	314	346	378	410	442	474	506
1	1	0	1	1	27	59	91	123	155	187	219	251	283	315	347	379	411	443	475	507
0	0	1	1	1	28	60	92	124	156	188	220	252	284	316	348	380	412	444	476	508
1	0	1	1	1	29	61	93	125	157	189	221	253	285	317	349	381	413	445	477	509
0	1	1	1	1	30	62	94	126	158	190	222	254	286	318	350	382	414	446	478	510
1	1	1	1	1	31	63	95	127	159	191	223	255	287	319	351	383	415	447	479	511

Dip Switch Position

DMX Address

Blow-out Diagram

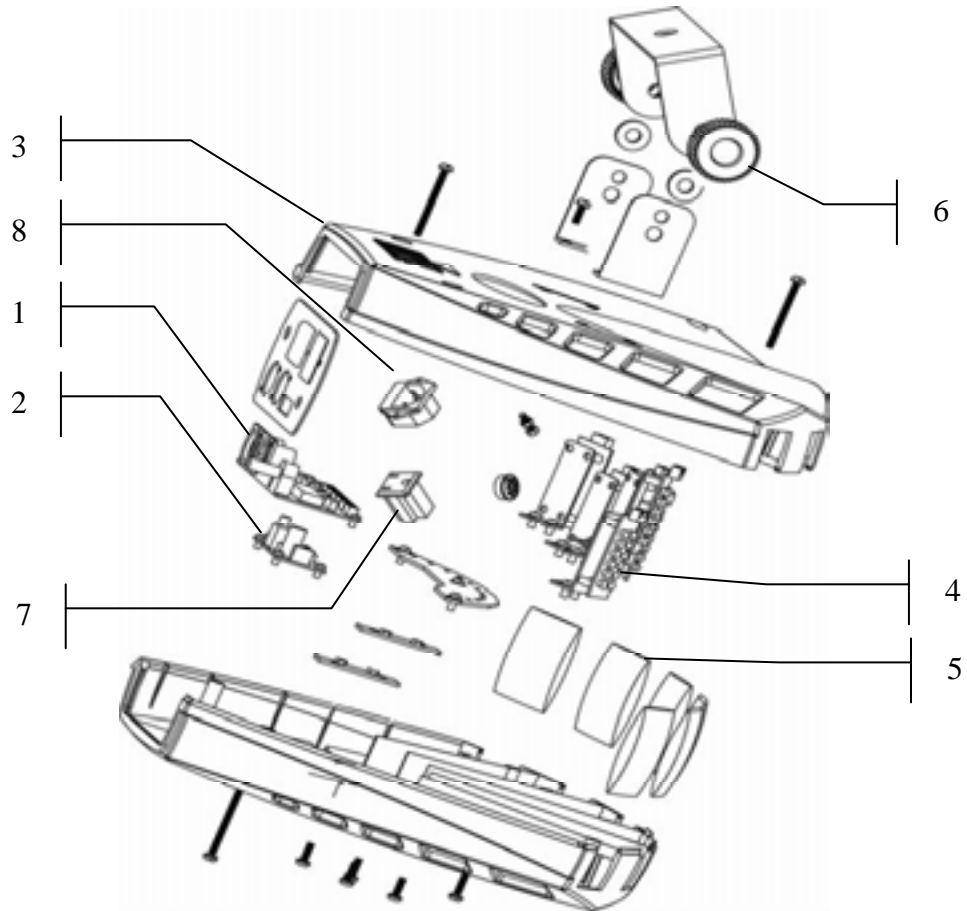

	Description	Part Number
1	Master PCB	P172-DERBYX
2	Electronic Transformer	P140-DERBYX
3	Case cover	P111-DERBYX
4	LED PCB	P222-DERBYX
5	Front Lens	P150-DERBYX
6	Bracket knob	P111-DERBYX
7	Power output	P176-PWERIN
8	Power input	P176-PWROUT

General Troubleshooting

Symptom(s)	Possible Solution(s)
1 or more LED's are not illuminating	Clean the fixture regularly to avoid any such failure. This fixture is convection cooled, which means that if the surface is kept clean and free of debris, then proper cooling will be allowed to occur
	An LED may have failed, resulting in an open circuit. In this event, all of the red, green, or blue in a single module will no longer illuminate. This does not mean that all of the LEDs have failed, but the circuit is wired in series.
	An LED may have failed, resulting in a short circuit. In this event, only the single LED which has failed will no longer function. This does not mean that all of the LEDs have failed, but the circuit is wired in series.
	<i>-Note: In the event of LED failure, a replacement LED PCB assembly may be purchased directly from CHAUVET Part#: P222-DERBYX</i>
1 or more LED's are producing very low output	Check that the lens assembly is installed properly. If the lens assembly is not aligned properly over the LEDs, then they will not project fully <i>-See section on Lens Assembly Installation</i>
	<i>-Note: In the event of LED failure, a replacement LED PCB assembly may be purchased directly from CHAUVET Part#: P222-DERBYX</i>
Breaker/Fuse keeps blowing	Check total load placed on the electrical circuit
	Check for a short in the electrical wiring: internal and/or external
Device has no power	Check device's fuse (internal)
	Check for power on Mains
	<i>-Note: In the event of autoswitching transformer failure, the unit can be sent in for repair; however, a replacement part can be ordered directly from CHAUVET Part#: P140-DERBYX</i>
Fixture is not responding to DMX	Check Control Panel settings for correct addressing
	Check DMX cables
	Check polarity switch settings on the controller
	Check cable connections
	Call service technician
	See page #10 for proper settings to operate in DMX mode
	<i>-Note: In the event of Master PCB failure, a replacement PCB can be ordered directly from CHAUVET Part#: P172-DERBYX</i>
Loss of signal	Use only DMX cables
	Install terminator
	Note: Keep DMX cables separated from power cables or black lights
Stand alone operation problem	See page #8 & #10 for details on proper settings and connections

If you still have a problem after trying the above solutions, please contact CHAUVET Technical Support at the location on the next page.

Technical Support

Address: Service Dept.
3000 N 29th Ct, Hollywood, FL 33020 (U.S.A.)
Support (Email): tech@chauvetlighting.com
Telephone: (954) 929-1115 - (Press 4)
Fax: (954) 929-5560 - (Attention: Service)
Website: <http://www.chauvetlighting.com>

5. APPENDIX

DMX Primer

There are 512 channels in a DMX-512 connection. Channels may be assigned in any manner. A fixture capable of receiving DMX 512 will require one or a number of sequential channels. The user must assign a starting address on the fixture that indicates the first channel reserved in the controller. There are many different types of DMX controllable fixtures and they all may vary in the total number of channels required. Choosing a start address should be planned in advance. Channels should never overlap. If they do, this will result in erratic operation of the fixtures whose starting address is set incorrectly. You can however, control multiple fixtures of the same type using the same starting address as long as the intended result is that of unison movement or operation. In other words, the fixtures will be slaved together and all respond exactly the same.

DMX fixtures are designed to receive data through a serial Daisy Chain. A Daisy Chain connection is where the DATA OUT of one fixture connects to the DATA IN of the next fixture. The order in which the fixtures are connected is not important and has no effect on how a controller communicates to each fixture. Use an order that provides for the easiest and most direct cabling. Connect fixtures using shielded two conductor twisted pair cable with three pin XLR male to female connectors. The shield connection is pin 1, while pin 2 is Data Negative (S-) and pin 3 is Data positive (S+). CHAUVET carries 3-pin XLR DMX compliant cables, DMX-10 (33'), DMX-4.5 (15') and DMX-1.5 (5')

General Maintenance

To maintain optimum performance and minimize wear fixtures should be cleaned frequently. Usage and environment are contributing factors in determining frequency. As a general rule, fixtures should be cleaned at least twice a month. Dust build up reduces light output performance and can cause overheating. This can lead to reduced lamp life and increased mechanical wear. Be sure to power off fixture before conducting maintenance.

Unplug fixture from power. Use a vacuum or air compressor and a soft brush to remove dust collected on external vents and internal components. Clean all glass when the fixture is cold with a mild solution of glass cleaner or Isopropyl Alcohol and a soft lint free cotton cloth or lens tissue. Apply solution to the cloth or tissue and drag dirt and grime to the outside of the lens. Gently polish optical surfaces until they are free of haze and lint.

The cleaning of internal and external optical lenses and/or mirrors must be carried out periodically to optimize light output. Cleaning frequency depends on the environment in which the fixture operates: damp, smoky or particularly dirty surrounding can cause greater accumulation of dirt on the unit's optics. Clean with soft cloth using normal glass cleaning fluid. - Always dry the parts carefully. - Clean the external optics at least every 20 days. Clean the internal optics at least every 30/60 days.

Returns Procedure

Returned merchandise must be sent prepaid and in the original packing, call tags will not be issued. Package must be clearly labeled with a Return Merchandise Authorization Number (RMA #). Products returned without an RMA # will be refused. Call CHAUVET and request RMA # prior to shipping the fixture. Be prepared to provide the model number, serial number and a brief description of the cause for the return. Be sure to properly pack fixture, any shipping damage resulting from inadequate packaging is the customer's responsibility. CHAUVET reserves the right to use its own discretion to repair or replace product(s). As a suggestion, proper UPS packing or double-boxing is always a safe method to use.

Note: If you are given an RMA #, please include the following information on a piece of paper inside the box:

- 1) Your name
- 2) Your address
- 3) Your phone number
- 4) The RMA #
- 5) A brief description of the symptoms

Claims

Damage incurred in shipping is the responsibility of the shipper; therefore the damage must be reported to the carrier upon receipt of merchandise. It is the customer's responsibility to notify and submit claims with the shipper in the event that a fixture is damaged due to shipping. Any other claim for items such as missing component/part, damage not related to shipping, and concealed damage, must be made within seven (7) days of receiving merchandise.

Technical Specifications

WEIGHT & DIMENSIONS

Length..... 11.9 in (302 mm)
Width 15 in (382 mm)
Height 7.4 in (187 mm)
Weight 4 lbs (1.8 kg)

POWER

Autoswitching power supply 100-240V AC 50.60Hz
Fuse..... 2A 250V
Power Consumption 24W (0.2A) max at 120V
Inrush Power (0.2A) at 120V
Power Output 27 units max at 120V

LIGHT SOURCE

LED..... 90 (30 Red, 30 Green, 30 Blue) 100,000 hrs

PHOTO OPTIC

Coverage Angle..... 96°

THERMAL

Maximum ambient temperature 104°F (40°C)

CONTROL & PROGRAMMING

Data input locking 3-pin XLR male socket
Data output..... locking 3-pin XLR female socket
Data pin configuration pin 1 shield, pin 2 (-), pin 3 (+)
Protocols DMX-512 USITT
DMX Channels 8

ORDERING INFORMATION

Derby X™ DERBYX
Optional bracket XBRACKET

WARRANTY INFORMATION

Warranty 2-year limited warranty



3000 N 29th Ct, Hollywood, FL 33020 U.S.A.

(800) 762-1084 – (954) 929-1115

FAX (954) 929-5560

www.chauvetlighting.com